

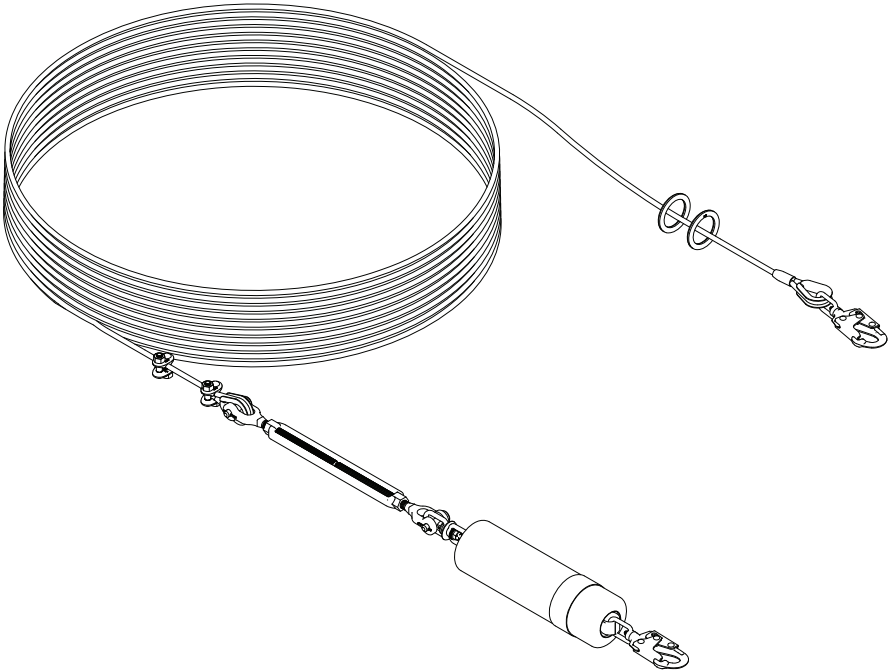

USER INSTRUCTIONS

CABLE HORIZONTAL LIFELINE

Complies with OSHA 29 CFR 1910 and 1926 regulations and requirements.



This manual applies to model numbers: L103060, L123060, L103030, L123030, L153030, L153060, L163030, L163060, L400001, L400002, L400003, L400030, L400060

WARNING!

Compliant fall protection equipment must only be used as it was designed. Users MUST read and follow all user instructions provided with the product. Before using a fall arrest system, users must be trained in the safe use of the system, as required by OSHA 29 CFR 1910.30 and 1926.503, or local safety regulations. Misuse or failure to heed these warnings and instructions may result in injury or even death.

WORK SAFE! WORK SMART!

IF YOU HAVE ANY QUESTIONS ABOUT THE PROPER USE OF THE EQUIPMENT, SEE YOUR SUPERVISOR, USER INSTRUCTIONS, OR CONTACT WERNER CO. FOR MORE INFORMATION.

Werner Co. Fall Protection
93 Werner Rd.
Greenville, PA 16125

724-588-2000
888-523-3371 toll free
888-456-8458 fax



⚠ WARNING!

Over- or under-tensioning may cause excessive wear or damage to system components and/or increased fall clearance requirements.

Only Self Retracting Lifelines (SRLs) may be connected to the Cable Horizontal Lifeline.

Never attach the unused leg of the Self Retracting Lifeline back to the full body harness at any location other than the lanyard parking attachment.

Never use combinations of components or subsystems that may affect, or interfere with, the safe function of each other.

In accordance with the requirements of OSHA 29 CFR 1910.140 and 1926.502, the Cable Horizontal Lifeline must be installed and used under the supervision of a "qualified" person as defined by OSHA 29 CFR 1910.140(b) and 1926.32(m).

All components of the Cable Horizontal Lifeline must be inspected prior to each use in accordance with the requirements of OSHA 29 CFR 1910.140 and 1926.502.

If inspection reveals any defect, inadequate maintenance, or unsafe condition, remove from service until a "qualified" person can determine the need for authorized repair or disposal.

Any equipment that has been subjected to the forces of arresting a fall, or that has a deployed load indicator, must be removed from service until a "qualified" person can determine the need for authorized repair or disposal.

The installation height of the Cable Horizontal Lifeline is dependent on the type of connecting subsystem attached. See CLEARANCE REQUIREMENTS.

When using SRLs as connecting devices, the Cable Horizontal Lifeline must be installed above the user. The installation height of the Cable Horizontal Lifeline and type of connecting subsystem attached both directly affect the fall clearance requirement.

When using SRLs, the increased potential for swing fall should be assessed in addition to the required fall clearance. Longer Self Retracting Lifelines (greater than 30 feet) may increase the potential for additional swing fall or free fall.

CABLE HORIZONTAL LIFELINE

USER INSTRUCTIONS

USE INSTRUCTIONS AND LIMITATIONS

IMPORTANT

Before use, the user must read and understand these User Instructions. Keep these User Instructions for reference.

PURPOSE

The Cable Horizontal Lifeline is an engineered flexible horizontal lifeline system, designed to be used as part of a complete personal fall arrest system, to provide horizontal mobility for up to two users and help limit the fall arrest forces in the event of a fall.

USE INSTRUCTIONS

1. Failure to follow all instructions and limitations on the use of the Cable Horizontal Lifeline may result in serious personal injury or death.
2. Before using a personal fall arrest system, employees must be trained in accordance with the requirements of OSHA 29 CFR 1910.30 and 1926.503 in the safe use of the system and its components.
3. Personal fall arrest systems, including the Cable Horizontal Lifeline, must be inspected prior to each use for wear, damage, and other deterioration. Defective components must be immediately removed from service, in accordance with the requirements of OSHA 29 CFR 1910.140 and 1926.502.
4. The complete fall protection system must be planned (including all components, calculating fall clearance, and swing fall) before using.
5. Users must have a rescue plan, and the means to implement it, that provides for the prompt rescue of employees in the event of a fall, or assures that employees are able to rescue themselves.
6. Store the Cable Horizontal Lifeline in a cool, dry, clean environment and out of direct sunlight when not in use.
7. After a fall occurs on the system, immediately remove from service until a “qualified” person can make the determination for reuse or disposal.

USE LIMITATIONS

1. **CAPACITY:** The Cable Horizontal Lifeline is designed for up to two users at one time, per system, with a capacity (including clothing, tools, etc.) up to 400 pounds (181 kg) total working weight per user, in conjunction with compatible connecting components.
2. **SPAN:** The Cable Horizontal Lifeline can be adjusted from a minimum of 10 feet (3.05m) to the maximum allowed by the included length of cable.
3. **SUPERVISION:** In accordance with the requirements of OSHA 29 CFR 1910.140 and 1926.502, the Cable Horizontal Lifeline must be installed and used under the supervision of a “qualified” person as defined by OSHA 29 CFR 1926.21.



4. **EXTENDED SUSPENSION:** The Cable Horizontal Lifeline is not intended for use in extended suspension applications.
5. **CORROSION:** Do not leave the Cable Horizontal Lifeline in environments where corrosion of metal parts could take place as a result of vapors from organic materials. Use near seawater or other corrosive environments may require more frequent inspections to ensure corrosion damage is not affecting the performance of the product.
6. **CHEMICAL HAZARDS:** Solutions containing acids, alkali, or other caustic chemicals, especially at elevated temperatures, may cause damage to the Cable Horizontal Lifeline. When working with such chemicals, frequent inspection of this equipment must be performed. Contact Werner Co. with any questions concerning the use of the Cable Horizontal Lifeline around chemical hazards.
7. **EXTREME TEMPERATURE:** The Cable Horizontal Lifeline is designed to be used in temperatures ranging from -40°F to +130°F (-40°C to +54°C). Protection should be provided for Cable Horizontal Lifeline when used near welding, metal cutting or similar activities. Contact Werner Co. with any questions concerning high temperature environments.
8. **ELECTRICAL HAZARDS:** Use extreme caution when working near high voltage power lines due to the possibility of electric current flowing through the Cable Horizontal Lifeline or connecting components.
9. **ANCHORAGES:** The end anchorage must be capable of supporting loads applied in all directions of 5,000 pounds (22.2kN), twice the maximum arrest load.
10. **COMPONENT COMPATIBILITY:** Only components approved by Werner Co. may be used with the Cable Horizontal Lifeline.
11. **SUBSYSTEMS:** Only connecting subsystems that limit the maximum arrest force to less than 1,800 pounds (8kN) may be used with the Cable Horizontal Lifeline.
12. **HEALTH:** Minors, pregnant women and anyone with a history of either back or neck problems should not use this equipment.
13. **TRAINING:** Do not use or install the Cable Horizontal Lifeline without proper training from a "competent" person as defined by OSHA's 29 CFR 1926.32(f).
14. **REPAIRS:** Only Werner Co., or persons or entities authorized in writing by Werner Co., may make repairs or alterations to the equipment.

ANCHORAGE REQUIREMENTS

ANCHORAGES

The Cable Horizontal Lifeline incorporates an in-line energy absorber. It is designed to limit the maximum arrest load to less than 2,500 pounds (11.1kN) on the end anchorages. Therefore, the end anchorage must be rated at a minimum strength of 5,000 pounds (22.2kN), twice the maximum arrest load.

CABLE HORIZONTAL LIFELINE

USER INSTRUCTIONS

All anchorages to which the Cable Horizontal Lifeline attaches must meet the requirements of ANSI Z359.2 and OSHA 29 CFR 1910 and 1926.

OSHA states:

Anchorage used for attachment of personal fall arrest equipment shall be independent of any anchorage being used to support or suspend platforms and capable of supporting at least 5,000 pounds (22.2 kN) per employee attached, or shall be designed, installed, and used as part of a complete personal fall arrest system which maintains a safety factor of at least two; and under the supervision of a “qualified” person.

ANSI Z359.2 states that anchorages selected for fall arrest systems must have a strength capable of sustaining static loads, applied in all permitted directions by the system:

- A) no less than 5,000 pounds (22.2 kN) for non-certified anchorages; or
- B) at least two times the maximum arresting force for certified anchorages;
- C) according to ANSI Z359.6, *Specifications and Design Requirements for Active Fall Protection Systems*.

The strength in (a) and (b) must be multiplied by the number of personal fall arrest systems attached to the anchorage, when more than one personal fall arrest system is attached to the anchorage.

ANCHORAGE CONNECTORS

Anchorage connectors function as an interface between the anchorage and the Cable Horizontal Lifeline for the purpose of coupling the system to the anchorage. The end anchorage connectors are designed to resist and transfer at least twice the maximum arrest load to the end anchorages.

CONNECTION REQUIREMENTS

COMPATIBILITY LIMITATIONS

All connecting subsystems must only be coupled to compatible connectors. OSHA 29 CFR 1926.502 prohibits snap hooks from being engaged to certain objects unless two requirements are met: snap hook must be a locking type and must be “designed for” making such a connection. Under OSHA 29 CFR 1926.502 “designed for” means that the manufacturer of the snap hook specifically designed the snap hook to be used to connect to the equipment in question.



The following connections must be avoided, because they can result in rollout* when a non locking snap hook is used:

- Direct connection of a snap hook to horizontal lifeline.
- Two (or more) snap hooks connected to one D-ring.
- Two snap hooks connected to each other.
- A snap hook connected back on its integral lanyard.
- A snap hook connected to a webbing loop or webbing lanyard.
- Improper dimensions of the D-ring, rebar, or other connection point in relation to the snap hook dimensions that would allow the snap hook keeper to be depressed by a turning motion of the snap hook.

***Rollout:** A process by which a snap hook or carabiner unintentionally disengages from another connector or object to which it is coupled.

SNAP HOOKS AND CARABINERS

Snap hooks and carabiners used in the Cable Horizontal Lifeline, marked with the ANSI Z359.12 standard, are self-locking with a minimum tensile break strength of 5,000 pounds (22.2kN), and a 3,600 pound (16kN) gate rating.

COMPATIBLE CONNECTIONS

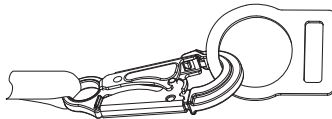

INCOMPATIBLE CONNECTIONS

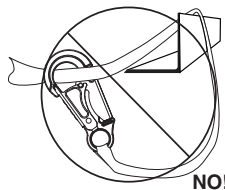
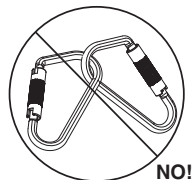
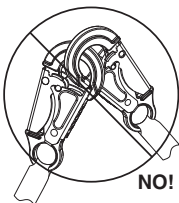
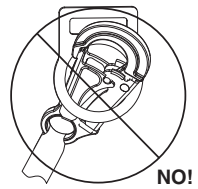
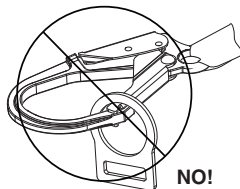
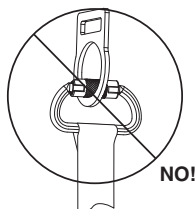
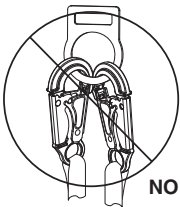

CABLE HORIZONTAL LIFELINE

USER INSTRUCTIONS

SYSTEM COMPONENTS

COMPATIBILITY LIMITATIONS

All components and subsystems used with the Cable Horizontal Lifeline have been tested as part of a pre-engineered flexible horizontal lifeline system. Only components and subsystems approved by Werner Co. are to be used with the Cable Horizontal Lifeline.

ANCHORAGE CONNECTORS

INTERMEDIATE STANCHION: L400003

The 6061-T6 aluminum post end stanchions are 7½ feet long with a 4 inch outside diameter and a ½ inch wall thickness. Each post has two 1¼ inch holes set 2 inches from the top for the intermediate pass through bracket.

END STANCHION: L400001

The 6061-T6 aluminum posts end stanchions are 7½ feet long with a 4 inch outside diameter and a ½ inch wall thickness. Each post has two 1¼ inch holes set 2 inches from the top for the A320001 D-Bolt Anchor.

CAST-IN-PLACE SLEEVE: L400002

The L400002 Cast-In-Place Sleeve is 12 inches tall with a 4 inch inside diameter and constructed of 4 inch Schedule 20 PVC. L400002 Cast-In-Place Sleeves must be cast to a minimum depth of 11 inches and no closer than 3½ inches to any side or edge, into 2,000 psi (13.8 MPa) or greater concrete.

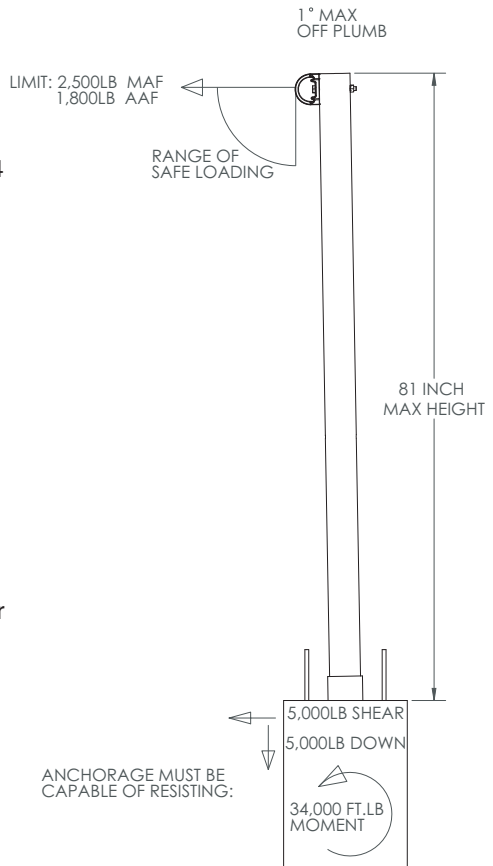



D-BOLT ANCHOR: A320001-WB

The 5,000 pound (22.2kN) anchorage connector is made from high tensile steel and attaches to an anchor structure with a $\frac{5}{8}$ inch -11 x 2 $\frac{1}{4}$ inch Grade 8 hex cap bolt, $\frac{5}{8}$ inch-11 Grade 8 hex nut and a $\frac{5}{8}$ inch high alloy medium split lock washer. (**A320001-WB includes bolt, nut and lock washer**)

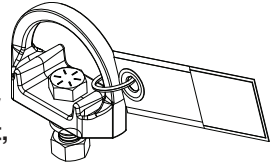

CROSS ARM STRAP: A111104

Constructed with 1 $\frac{3}{4}$ inch high strength polyester and 3 inch nylon, the 4 foot Cross Arm Strap is designed to wrap around a choke with the 12 inch soft loop to anchor structures to create a 5,000 pound (22.2kN) anchor point.

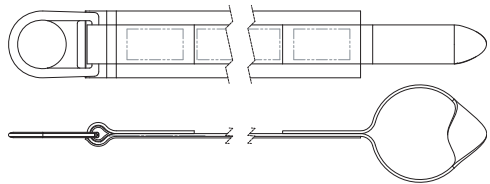

LIFELINE ASSEMBLY

REPLACEMENT CABLE L163030 AND L163060

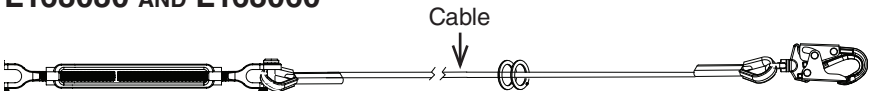

REPLACEMENT CABLE ASSEMBLY: L163030 AND L163060

The Cable in the Cable Horizontal Lifeline is 7x19 $\frac{3}{8}$ inch galvanized steel wire rope. The Cable comes with one end permanently terminated with a thimble and swivel snap hook. The other end has a button stop to prevent the cable from unraveling, and is used with the supplied thimble and two fist grips for adjustment in length.

SYSTEMS

L103030, L103060, L123030, L123060, L153030, L153060 L400030 AND L400060

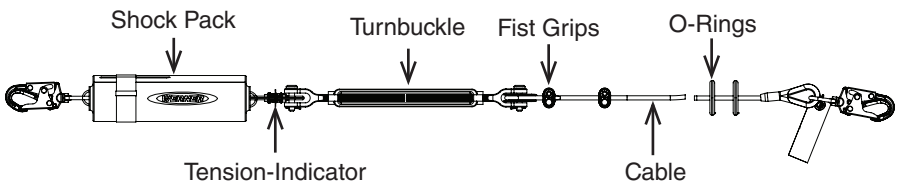

CABLE HORIZONTAL LIFELINE

USER INSTRUCTIONS

SHOCK PACK

The shock pack is designed to limit the maximum arrest load to less than 2,500 lbf (11.1kN) on the end anchorages. The shock pack is constructed with polyester web and tear web with a polyester cover to protect from UV, abrasion and wear. The cover also includes the labels with a protective sleeve.

TENSION-INDICATOR

The Tension-Indicator is designed to easily identify when the Cable Horizontal Lifeline has been properly tensioned. The Tension-Indicator is constructed with forged zinc plated steel and stainless steel.

O-RINGS

The 2 inch (50.8mm) O-rings are made from high tensile steel and marked to ANSI Z359.12 with a minimum breaking strength of 5,000 pounds (22.2kN).

INSTALLATION



WARNING!

All components of the Cable Horizontal Lifeline must be inspected prior to each use in accordance with the requirements of OSHA 29 CFR 1910.140 and 1926.502.

BEFORE EACH USE

Users must have a rescue plan, and the means to implement it, that provides for the prompt rescue of employees in the event of a fall or assures that employees are able to rescue themselves.

The user must read and understand these User Instructions, as well as the User Instructions for every component and subsystem of the personal fall arrest system.

The entire Cable Horizontal Lifeline, and its subsystems, must be inspected prior to each use. See INSPECTION.



SWING FALLS

To minimize the possibility of a swing fall, work as directly under or adjacent to the Cable Horizontal Lifeline as possible. Striking objects horizontally, due to the pendulum effect, may cause serious injury. Swing falls also increase the vertical fall distance of a worker, compared to a fall directly below the connection point. See CLEARANCE REQUIREMENTS.

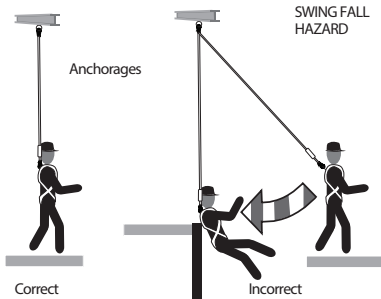

MULTIPLE SPAN SYSTEMS

A Multiple Span System is a Cable Horizontal Lifeline that includes the use of an intermediate anchorage connector. Intermediate anchorage connectors may be added to help reduce the required clearance, by decreasing the length of the span.

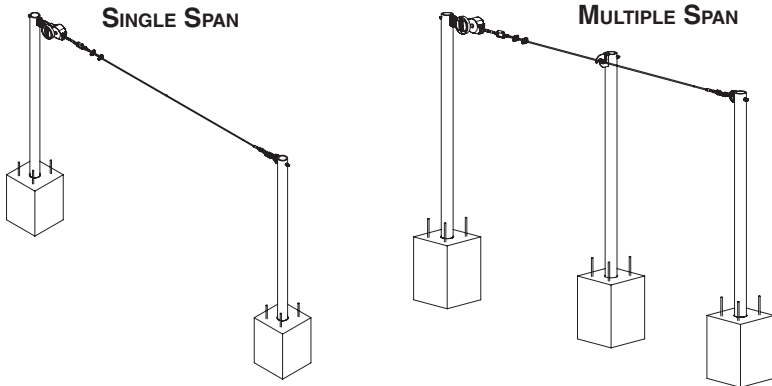

WARNING!

The installation height of the Cable Horizontal Lifeline is dependent on the type of connecting subsystem attached. See CLEARANCE REQUIREMENTS.

STEP 1A: INSTALL CAST-IN-PLACE SLEEVE

Cast the L400002 Cast-In-Place Sleeve into freshly poured concrete of 2,000 psi (13.8 MPa) or greater. Use cap to seal the end of the Cast-In-Place Sleeve preventing fresh concrete from filling the sleeve. The Cast-In-Place Sleeve must be cast into the concrete no closer than 3½ inches to any side or edge. When

CABLE HORIZONTAL LIFELINE

USER INSTRUCTIONS

stirrups exist in the column within 2½ inches of the top surface, the minimum column size must be no less than 12 inches. When no stirrups exist the minimum column size must be no less than 17 inches. Cast-In-Place Sleeve must be cast to a minimum depth of 11 inches. Ensure the Cast-In-Place Sleeve does not float upwards in the concrete before it sets. The Cast-In-Place Sleeve must be cast no more than 1 degree off plumb in the concrete.

Note: Do not use a Cast-In-Place Sleeve that does not meet all of the above requirements.

STEP 1B: INSTALL CROSS ARM STRAP ANCHORAGE CONNECTOR

With labels on the outward facing surface of the Cross Arm Strap, wrap web around the anchorage structure and pass the small D-ring on one end through the web loop on the other end. Wrap as many times as necessary to achieve desired length. Pull small D-ring to tighten (choke) the anchorage. The small D-ring is the anchorage connector at the connection point.

STEP 1C: INSTALL D-BOLT ANCHORAGE CONNECTOR

Drill a $\frac{21}{32}$ inch (17mm) hole where needed in the anchorage structure using a suitable drill bit for penetration. Remove any burred edges from the structure. Attach the D-Bolt Anchorage Connector using supplied $\frac{5}{8}$ inch -11 x 2¼ inch Grade 8 steel bolt, nut and lock washer. Insert supplied bolt through D-Bolt and pre-drilled hole. Ensure bolt is pushed through completely and back surface of the D-Bolt is flush against the anchorage structure. Slide the supplied lock washer over the threads of the bolt until the washer is against the surface of the anchorage structure. Thread nut onto bolt until it meets washer. Ensure D-Bolt is oriented correctly and torque to 125 lbf-ft (17.3kgf-m).

STEP 2: INSERT END STANCHION

Insert L400001 End Stanchion into L400002 Cast-In-Place Sleeve. Concrete must have a cured compressed strength of 2,000 psi (13.8 MPa) before inserting stanchions.

STEP 3: CONNECT SNAP HOOK END OF CABLE

Attach the swivel snap hook that is connected to the end of the cable to the installed anchorage connector. This end of the system is the dead-end of the Cable Horizontal Lifeline system.

STEP 4: CONNECT SNAP HOOK ON SHOCK PACK

Connect the swivel snap hook attached to the shock pack to the remaining installed anchorage connector. This end of the system is the live end of the Cable Horizontal Lifeline system.



STEP 5: INSTALL THE TURNBUCKLE

Extend the Jaw and Jaw Turnbuckle until one inch of threaded rod remains visible on each end inside the turnbuckle body and remove the nut and bolt from one end. Connect the end of the Turnbuckle directly to the Tension-Indicator with the nut and bolt.

STEP 6: ATTACH THE CABLE

Remove the nut and bolt from the opposite end of the turnbuckle. Place the thimble through the jaws of the turnbuckle and secure by passing bolt through the thimble and secure with nut. Turn back cable over the thimble until the desired length is reached and apply first fist grip $5\frac{1}{4}$ inches from the thimble. Use torque wrench to tighten fist grip evenly, alternating from one nut to the other until reaching 45 lbf-ft (6.22 kgf-m) of torque. Apply the second fist grip as near the thimble as possible. Use torque wrench to tighten fist grip evenly, alternating from one nut to the other until reaching 45 lbf-ft (6.22 kgf-m) of torque. If necessary, pass the cable lifeline through the hooks of the intermediate bracket.

Note: The Cable Horizontal Lifeline may be assembled on the ground and attached to the L400001 End Stanchion before inserting stanchion into L400002 Cast-In-Place Sleeve.

STEP 7: TENSION THE SYSTEM

Use the Turnbuckle to adjust tension in the system. The system is properly tensioned when the large washer in the Tension-Indicator can spin freely by hand.

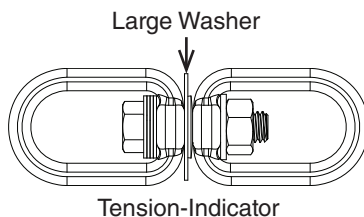

WARNING!

Over- or under-tensioning may cause excessive wear or damage to system components and/or increased fall clearance requirements.

CONNECTION

NUMBER OF USERS

The Cable Horizontal Lifeline is designed for up to two users at one time, per system, with a capacity (including clothing, tools, etc.) up to 400 pounds (181kg) total working weight per user, in conjunction with compatible connecting components.

CABLE HORIZONTAL LIFELINE

USER INSTRUCTIONS

CAUTION!

When two users are connected to the same Cable Horizontal Lifeline, a single fall may result in pulling the second person off the work surface, causing a secondary fall.

Precautions should be taken to reduce the risk of secondary falls, including limiting each Cable Horizontal Lifeline to a single user when and where possible or rigging the lifeline for restraint to reduce the risk of any users falling.

SELF-RETRACTING LIFELINES (SRLs)

Attach the housing connector of the self-retracting lifeline to the O-ring of the Cable Horizontal Lifeline. The opposing end is connected to the dorsal D-ring of the full body harness. **Never attach an additional energy absorbing lanyard or self-retracting lifeline to lengthen the lifeline.**

WARNING!

Never attach the unused leg of the SRL back to the full body harness at any location other than the lanyard parking attachment.

WARNING!

Never use combinations of components or subsystems that may affect, or interfere with, the safe function of each other.

HOUSING OF THE SRL TO HARNESS

Lighter weight self-retracting lifelines may be attached by the housing connector directly to the dorsal D-ring of the full body harness. The opposing end is connected to the O-ring of the Cable Horizontal Lifeline.

PERSONAL SRLs AND TWIN LEG SRLs

There are many different ways Personal SRLs and Twin Leg SRLs attach to the full body harness. Follow User Instructions supplied with the product.



INSPECTION AND MAINTENANCE

WARNING!

If inspection reveals any defect, inadequate maintenance, or unsafe condition, remove from service until a “qualified” person, as defined by OSHA 29 CFR 1910.140(b) and 1926.32(m), can determine the need for authorized repair or disposal.

CAUTION!

Proper Personal Protective Equipment must be worn when performing Inspection and Maintenance procedures.

FREQUENCY

All components of the Cable Horizontal Lifeline must be inspected prior to each use, and annually by an OSHA defined “qualified” person other than the user. Local, state, governmental and jurisdictional agencies governing occupational safety may require the user to conduct more frequent or mandatory inspections.

CRITERIA

WARNING!

Any equipment that has been subjected to the forces of arresting a fall, or that has a deployed load indicator, must be removed from service until a “qualified” person can make the determination for reuse or disposal.

The tension of the system must be checked and adjusted. The Tension-Indicator can be used to check the tension by the same method as used during installation. See step 7.

All components and subsystems of the Cable Horizontal Lifeline must be inspected.

All markings must be legible and attached to the product.

CABLE HORIZONTAL LIFELINE

USER INSTRUCTIONS

All equipment must be free of corrosion, chemical attack, alteration, excessive heating or wear.

Cable must be inspected for kinks, broken strands, corrosion, abrasion, or other signs of wear and/or damage. Swaged terminations should be secure with the thimble tight and no visible damage.

All snap hooks and carabiners must be able to self-close and lock. All hardware must be free of cracks, sharp edges, deformation, corrosion, or any evidence of defect.

All components of the full body harness and/or self retracting lifeline must be inspected. See user instructions supplied with the product.

UNINSTALLATION

REMOVAL OF SYSTEM

When work is complete, the system should be removed from the job site and stored.

To remove the system:

Use the Turnbuckle to release tension in the system. Disconnect the swivel snap hook attached to the shock pack from the end stanchion. Disconnect the swivel snap hook that is connected to the end of the cable from the remaining end stanchion.

The cable and stanchions should be stored properly to avoid damage during storage or kinking of the cable when taking it out of storage.

CLEANING AND STORAGE

CLEANING

Cleaning maintenance may be performed by the user. The Cable Horizontal Lifeline may be wiped down with a mild detergent and clean water solution, and rinsed with a dampened clean cloth to remove detergent. The hardware can also be wiped down to remove grease or dirt with a clean dry cloth.

STORAGE

The Cable Horizontal Lifeline should be stored in a cool, dry place out of direct sunlight when not in use. Do not store where damage from environmental factors such as heat, light, excessive moisture, oil, chemicals and their vapors, or other degrading elements may be present.



Do not store damaged equipment or equipment in need of maintenance in the same area as product approved for use. Equipment that has been stored for an extended period must be inspected as defined in these User Instructions prior to use.

CLEARANCE REQUIREMENTS

STANCHION DIRECT OVERHEAD USE - PAGE 17

STANCHION OVERHEAD USE - PAGE 18

GENERAL OVERHEAD USE - PAGE 19

LEADING EDGE APPLICATIONS - PAGE 20

CLEARANCE CHARTS

The following clearance charts are for user up to **310 pounds** (141 kg) and show the required clearance distance that must remain clear of obstructions between the walking/working surface and the lower level or nearest obstruction below.

The clearance requirements include the following in the total fall distance:

- the deflection of anchorage connectors and lifeline,
- the elongation of the full body harness and the user,
- the vertical component of any swing fall,
- and a clearance safety margin of 2 feet (0.6m).

The clearance requirements account for performance of the system and the number of users on the system.

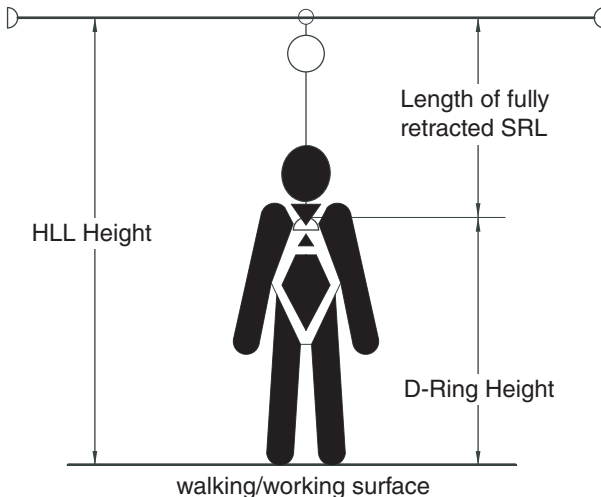

CABLE HORIZONTAL LIFELINE

USER INSTRUCTIONS

STANCHION DIRECT OVERHEAD USE

Cable Horizontal Lifeline must be connected to Werner Stanchions and work must be performed directly adjacent to the Horizontal Lifeline. Work performed beyond directly adjacent to the Horizontal Lifeline would NOT use this Clearance Chart.

The below clearances are for SRL Model Numbers: R230007, R230011, R230018, R210010, R410008LE, R430006 and R431006

SPAN (UP TO...)	ONE USER	TWO USERS
10ft (3.0m)	5' 3" (1.6m)	5' 9" (1.8m)
20ft (6.1m)	6' 0" (1.8m)	7' 1" (2.2m)
30ft (9.1m)	6' 8" (2.0m)	8' 4" (2.6m)
40ft (12.2m)	7' 4" (2.3m)	9' 9" (3.0m)
50ft (15.2m)	8' 0" (2.4m)	11' 1" (3.4m)
60ft (18.3m)	8' 8" (2.7m)	12' 6" (3.8m)



WARNING!

Cable Horizontal Lifeline must ALWAYS be installed above the user. The installation height of the Cable Horizontal Lifeline and type of connecting subsystem attached directly affect the fall clearance requirement.



STANCHION OVERHEAD USE

Cable Horizontal Lifeline must be connected to Werner Stanchions and work must be performed within 30 degrees of the Horizontal Lifeline. Work performed beyond 30 degrees must use Leading Edge Applications charts on page 20.

Fully Retracted SRLs that DO NOT extend below the D-Ring when attached to the HLL can use General Overhead Use charts on page 19.

SELF RETRACTING LIFELINES - ANSI Z359.14 CLASS A

The below clearances are for SRL Model Numbers: R230007, R230011, R230018, R210010, R410008LE, R410020, R410030, R410050, R410020LE, R410030LE, R430006 and R431006

SPAN (UP TO...)	ONE USER	TWO USERS
10ft (3.0m)	6' 1" (1.9m)	7' 0" (2.1m)
20ft (6.1m)	6' 10" (2.1m)	9' 0" (2.7m)
30ft (9.1m)	7' 9" (2.4m)	10' 10" (3.3m)
40ft (12.2m)	8' 8" (2.7m)	12' 7" (3.8m)
50ft (15.2m)	9' 6" (2.9m)	14' 6" (4.4m)
60ft (18.3m)	10' 4" (3.2m)	16' 3" (5.0m)

SELF RETRACTING LIFELINES - ANSI Z359.14 CLASS B

The below clearances are for SRL Model Numbers: R210020, R210030, R210040, R210060, R213030, R213060, R230018, R230050, and R410065LE

SPAN (UP TO...)	ONE USER	TWO USERS
10ft (3.0m)	7' 0" (2.1m)	7' 6" (2.3m)
20ft (6.1m)	7' 10" (2.4m)	9' 1" (2.8m)
30ft (9.1m)	8' 9" (2.7m)	11' 2" (3.4m)
40ft (12.2m)	9' 8" (3.0m)	13' 1" (4.0m)
50ft (15.2m)	10' 7" (3.2m)	14' 10" (4.5m)
60ft (18.3m)	11' 6" (3.5m)	16' 9" (5.1m)

CABLE HORIZONTAL LIFELINE

USER INSTRUCTIONS

GENERAL OVERHEAD USE

Cable Horizontal Lifeline must be installed at a height above the user, so that the fully retracted SRL attached to the Horizontal Lifeline does not extend below the dorsal D-ring of the user. Work must be performed within 30 degrees of the Horizontal Lifeline. Work performed beyond 30 degrees must use Leading Edge Applications charts on page 20.

SELF RETRACTING LIFELINES - ANSI Z359.14 CLASS A

The below clearances are for SRL Model Numbers: R230007, R230011, R230018, R210010, R410008LE, R410020, R410030, R410050, R410020LE, R410030LE, R430006 and R431006

SPAN (UP TO...)	ONE USER	TWO USERS
10ft (3.0m)	6' 0" (1.8m)	6' 6" (2.0m)
20ft (6.1m)	6' 10" (2.1m)	8' 4" (2.6m)
30ft (9.1m)	7' 9" (2.4m)	10' 2" (3.1m)
40ft (12.2m)	8' 8" (2.7m)	12' 0" (3.7m)
50ft (15.2m)	9' 6" (2.9m)	13' 9" (4.2m)
60ft (18.3m)	10' 3" (3.1m)	15' 7" (4.8m)

SELF RETRACTING LIFELINES - ANSI Z359.14 CLASS B

The below clearances are for SRL Model Numbers: R210020, R210030, R210040, R210060, R213030, R213060, R230018, R230050, and R410065LE

SPAN (UP TO...)	ONE USER	TWO USERS
10ft (3m)	6' 8" (2.0m)	7' 1" (2.2m)
20ft (6.1m)	7' 7" (2.3m)	8' 8" (2.7m)
30ft (9.1m)	8' 6" (2.6m)	10' 9" (3.3m)
40ft (12.2m)	9' 4" (2.9m)	12' 8" (3.9m)
50ft (15.2m)	10' 3" (3.1m)	14' 6" (4.4m)
60ft (18.3m)	11' 1" (3.4m)	16' 4" (5.0m)



LEADING EDGE APPLICATIONS

Fall clearance required for attaching Self Retracting Lifelines with Leading Edge Capabilities, up to 310 pound (141 kg) users and the Cable Horizontal Lifeline installed at foot level or the users walking/working surface. All fall clearances are measured from the walking/working surface to the next obstruction below.

The below clearances are for SRL-LE Model Numbers: R410008LE, R410020LE, R410030LE and R410065LE

SPAN (UP TO...)	SET BACK DISTANCE	ONE USER	SET BACK DISTANCE	TWO USERS
10ft (3.0m)	2' 0" (0.6m)	18' 10" (5.8m)	2' 0" (0.6m)	19' 3" (5.9m)
20ft (6.1m)	3' 0" (0.9m)	20' 0" (6.1m)	4' 0" (1.2m)	21' 1" (6.4m)
30ft (9.1m)	4' 0" (1.2m)	21' 2" (6.5m)	6' 0" (1.8m)	22' 10" (6.9m)
40ft (12.2m)	5' 0" (1.5m)	22' 4" (6.8m)	8' 0" (2.4m)	24' 10" (7.6m)
50ft (15.2m)	7' 0" (2.1m)	23' 9" (7.3m)	10' 0" (3.0m)	26' 9" (8.2m)
60ft (18.3m)	8' 0" (2.4m)	25' 2" (7.7m)	12' 0" (3.7m)	29' 4" (9.0m)

CABLE HORIZONTAL LIFELINE

USER INSTRUCTIONS

LABELS



93 Werner Road
Greenville, PA 16125
1-888-523-3371
www.wernerco.com

END STANCHION for Horizontal Lifeline

Model: L400001

Serial Number: 

Date of Manufacture: 0 5 1751 13609 4

Standards OSHA 29 CFR 1910, 1926

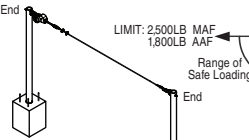
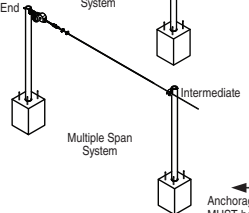
1" Max Off Plumb

LIMIT: 2500LB MAF
1800LB AAF

Range of Safe Loading

81 Inch Max Height

5,000lb Shear
5,000lb Down
34,000 ft.lb Moment

Anchorage MUST be capable of resisting:

⚠ **WARNING**

This product is intended to be used with an energy absorbing device which limits the Maximum Arrest Force to less than 2,500lbs (11.1kN) and the Average Arrest force to less than 1,800 lbs (8kN). Only connecting subsystems which limit the maximum arresting force of the user to less than 1,800 lbs (8kN) are approved for use with this system.

Compliant fall protection equipment must only be used as it was designed. Users MUST read and follow all user instructions provided with the product. Before using a fall arrest system, users must be trained in the safe use of the system, as required by OSHA 29 CFR 1910.30 and 1926.503, or local safety regulations. Product must be inspected prior to each use according to the user instructions,

and additionally by a qualified person who is not the user, at intervals of no more than one year.

Only make compatible connections. User repairs and alterations are NOT permitted. Avoid physical and environmental hazards such as thermal, exposure to sharp edges and abrasive surfaces, machinery, and electrical and chemicals sources. For proper use see supervisor, user instructions, or contact Werner Co.

This system is only to be used by Authorized Persons. Any equipment that has been subjected to the forces of arresting a fall, or that has a deployed load indicator, must be removed from service until a "qualified person" can make the determination for reuse or disposal.

© 2018 Werner Co., P/N 117558-02 Rev A 07/18



93 Werner Road
Greenville, PA 16125
1-888-523-3371
www.wernerco.com

INTERMEDIATE STANCHION for Horizontal Lifeline

Model: L400003

Serial Number: 

Date of Manufacture: 0 5 1751 13609 8

Standards OSHA 29 CFR 1910, 1926

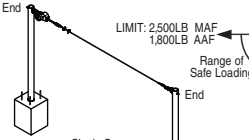
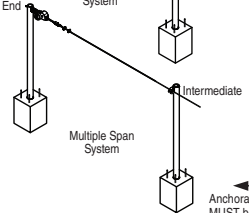
1" Max Off Plumb

LIMIT: 2500LB MAF
1800LB AAF

Range of Safe Loading

81 Inch Max Height

5,000lb Shear
5,000lb Down
34,000 ft.lb Moment

Anchorage MUST be capable of resisting:

⚠ **WARNING**

This product is intended to be used with an energy absorbing device which limits the Maximum Arrest Force to less than 2,500lbs (11.1kN) and the Average Arrest force to less than 1,800 lbs (8kN). Only connecting subsystems which limit the maximum arresting force of the user to less than 1,800 lbs (8kN) are approved for use with this system.

Compliant fall protection equipment must only be used as it was designed. Users MUST read and follow all user instructions provided with the product. Before using a fall arrest system, users must be trained in the safe use of the system, as required by OSHA 29 CFR 1910.30 and 1926.503, or local safety regulations. Product must be inspected prior to each use according to the user instructions,

and additionally by a qualified person who is not the user, at intervals of no more than one year.

Only make compatible connections. User repairs and alterations are NOT permitted. Avoid physical and environmental hazards such as thermal, exposure to sharp edges and abrasive surfaces, machinery, and electrical and chemicals sources. For proper use see supervisor, user instructions, or contact Werner Co.

This system is only to be used by Authorized Persons. Any equipment that has been subjected to the forces of arresting a fall, or that has a deployed load indicator, must be removed from service until a "qualified person" can make the determination for reuse or disposal.

© 2018 Werner Co., P/N 117558-02 Rev A 07/18



WARNING

Compliant fall protection equipment must only be used as it was designed. Users **MUST** read and follow all user instructions provided with the product. Before using a fall arrest system, users must be trained in the safe use of the system, as required by OSHA 29 CFR 1910.30 and 1926.503, or local safety regulations. Product must be inspected prior to each use according to the user instructions, and additionally by a competent person who is not the user, at intervals of no more than one year. Only make compatible connections. User repairs and alterations are NOT permitted. Avoid physical and environmental hazards such as thermal, exposure to sharp edges and abrasive surfaces, machinery, and electrical and chemicals sources. For proper use see supervisor, user instructions, or contact Werner Co.

This system is only to be used by Authorized Persons.

Any equipment that has been subjected to the forces of arresting a fall, or that has a deployed load indicator, must be removed from service until a "qualified person" can make the determination for reuse or disposal.

ADVERTENCIA

El equipo de protección contra caídas que cumple las normas sólo se puede utilizar según se diseñó. Los usuarios **DEBEN** leer y seguir todas las instrucciones del usuario suministradas con el producto. Antes de utilizar un sistema de detención de caídas, los usuarios deben recibir capacitación acerca del uso seguro del sistema, según lo requerido por OSHA 29 CFR 1910.30 y 1926.503, o los reglamentos de seguridad locales. Antes de cada uso, el producto debe ser inspeccionado de acuerdo con las instrucciones del usuario, y adicionalmente, por una persona competente que no sea el usuario, en intervalos no superiores a un (1) año. Sólo realice conexiones compatibles. NO se permiten reparaciones y alteraciones por parte del usuario. Evite los peligros físicos y medioambientales tales como los peligros térmicos, exposición a bordes filosos y superficies abrasivas, maquinaria, y fuentes eléctricas y químicas. Para conocer el uso apropiado, hable con su supervisor, vea las instrucciones del usuario, o comuníquese con Werner Co.

Este sistema sólo es utilizado por Personas Autorizadas.

Cualquier equipo que haya sido sometido a las fuerzas de detención de una caída, o que tenga un indicador de carga desplegado, debe ser retirado del servicio hasta que una "persona calificada" pueda determinar reutilizarlo desecho.

93 Werner Road, Greenville, PA 16125
888-523-3371 • www.wernerco.com
© 2017 Werner Co. P/N 113414-01 Rev A 3/17

CABLE HORIZONTAL LIFELINE

USER INSTRUCTIONS



Cable Horizontal Lifeline Linea de vida Horizontal de Cable

Model / Modelo:

Mark Number
Número de Calificación **1**

Max. System Length:
Longitud Máxima
del Sistema:

Serial Number:
Número de Serie:

Date of
Manufacture:
Fecha de
Fabricación:

Maximum Users:
Usuarios Máximo : **2**

Max. Capacity per User: **400 lb**
Capacidad Máx. por Usuario : **181 kg**

Minimum Anchorage Strength:
Resistencia Mínima del Ancladero:
5,000lbs / 22.2 kN

See instructions for fall clearance requirements

Vea las instrucciones para conocer los requisitos de espacio libre de caída.

Only connecting subsystems that limit the maximum arrest force to less than 1,800 pounds (8 kN) are approved for use with this system.

Para uso con este sistema, sólo están aprobados los subsistemas conectores que limitan la fuerza de detención máxima a menos de 1.800 libras (8 kN).

Inspection Log/Registro de Inspección

Year Año 1	Year Año 2	Year Año 3	Year Año 4	Year Año 5	
					1
					2
					3
					4
					5
					6
					7
					8
					9
					10
					11
					12

Standards/Estándares
OSHA 29 CFR 1910, 1926

93 Werner Road, Greenville, PA 16125
1-888-523-3371

www.wernerco.com

© 2017 Werner Co.

P/N 113413-01 Rev A 3/17



EQUIPMENT RECORD

MODEL NUMBER

PURCHASE DATE

SERIAL NUMBER

ASSIGNED TO

DATE
MANUFACTURED

SPECIFICATION

WERNER Co. CABLE HORIZONTAL LIFELINE

This product meets OSHA 29 CFR 1910.140 and 1926.502 regulations for the horizontal lifeline component of a complete personal fall arrest system.

Individually bar coded model and serial numbers, location and date of manufacture are on product label.

INSPECTION RECORD

DATE	INSPECTOR	PASS/FAIL

DATE	INSPECTOR	PASS/FAIL

CABLE HORIZONTAL LIFELINE

USER INSTRUCTIONS

NOTES



NOTES

CABLE HORIZONTAL LIFELINE

USER INSTRUCTIONS

NOTES



Werner Co. Fall Protection
93 Werner Rd. Greenville, PA 16125
724-588-2000 • 888-523-3371 toll free • 888-456-8458 fax