

INSPECTION AND MAINTENANCE LOG

MODEL NUMBER: _____

DATE OF MANUFACTURE: _____

Date	Part Number	Comments	Inspector Name

Inspection:
Official periodic inspection must be made at least annually. The inspection must be performed by a competent or qualified person other than the user. If severe environmental conditions exist then inspections must be carried out more frequently. All inspection results must be logged in the space provided above.

1. Inspect unit for visible signs of damage or wear that could affect operation. For example: kinked or frayed cables.
2. Ensure all labeling is affixed to the unit.
3. Check spoons and end termination operate smoothly with no metal burrs.
4. When reusing a previously drilled hole, inspect for debris or wallowing.
5. Record inspection results in the space provided above.

*** If inspection reveals any damage that could affect the strength or operation of this device, inadequate maintenance, or an unsafe condition, proper disposal is required. The anchorage connector must be rendered unusable and then properly discarded.**



Reusable Bolt Anchor

5,000-lbf / 22kN

Model: A515000

Assembled in the USA

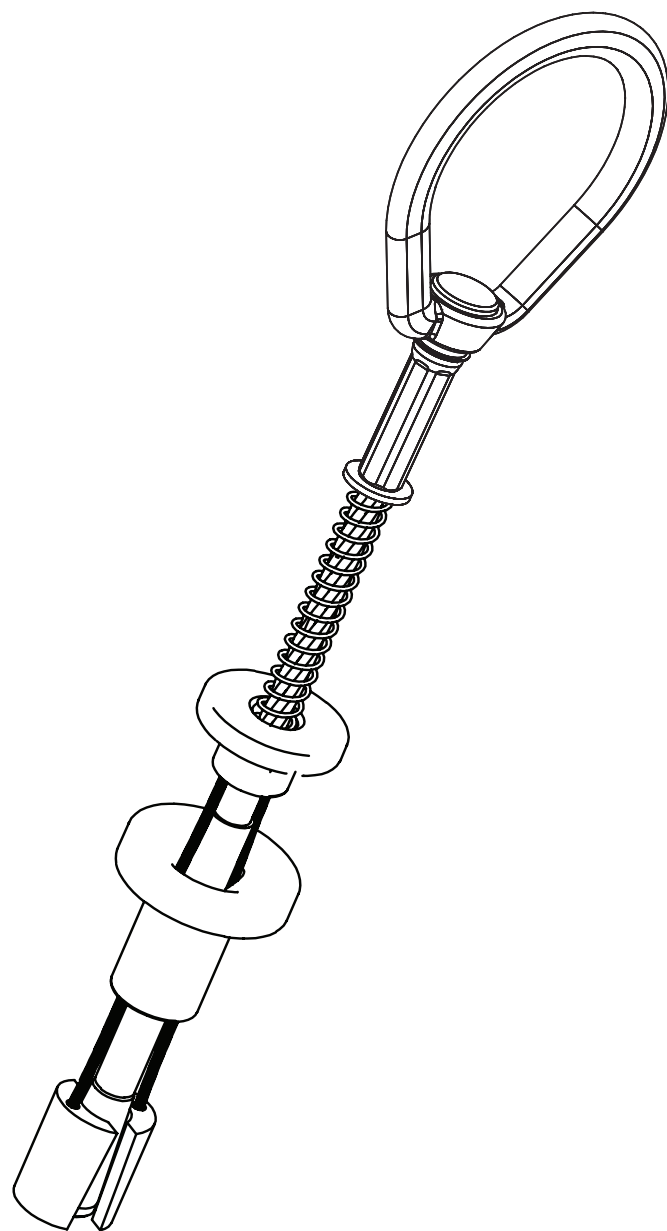

WARNING: ALL USERS OF THIS EQUIPMENT MUST READ AND UNDERSTAND ALL INSTRUCTIONS. FAILURE TO DO SO MAY RESULT IN SERIOUS INJURY OR DEATH. USERS SHOULD BE FAMILIAR WITH PERTINENT REGULATIONS GOVERNING THIS EQUIPMENT. ALL USERS OF THIS PRODUCT MUST BE PROPERLY INSTRUCTED ON HOW TO USE THE DEVICE. AVOID CONTACT WITH PHYSICAL HAZARDS (THERMAL, CHEMICAL, ELECTRICAL, ETC.). MAKE ONLY COMPATIBLE CONNECTIONS.

Patent # US 7,357,363 B2 / US 7,011,281 B2 / US 6,729,821 B2 V1.0-C

Read This Instruction Manual Carefully Before Using This Equipment.

User Instructions must always be available to the user and are not to be removed except by the user of this equipment. For proper use, see supervisor, User Instructions, or contact the manufacturer. Werner Co. can supply additional information upon request.

⚠ WARNING ⚠

Compliant fall arrest and emergency rescue systems help prevent serious injury during fall arrest. Users and purchasers of this equipment must read and understand the User Instructions provided for correct use and care of this product. All users of this equipment must understand the instructions, operation, limitations and consequences of improper use of this equipment and be properly trained prior to use in accordance with applicable standards. All references to "applicable standards" refer to ANSI, OSHA, state, local, and/or federal standards that apply to approved use. The local competent person must keep these instructions, make them available to users and require their use

Misuse or failure to follow warnings and instructions may result in serious personal injury or death.

PURPOSE

The A515000 are anchorage connectors designed to function as an interface between the anchorage and a fall arrest, work positioning, rope access, or rescue system for the purpose of coupling the system to the anchorage. Any references to "anchorage connector" in this manual include, and apply to, the A515000.

USE INSTRUCTIONS

1. A user must be of sound mind and body to properly and safely use this equipment in normal and emergency situations.
2. Before using a personal fall arrest system, user must be trained in accordance with the requirements of applicable standards in the safe use of the system and its components.
3. Only use with systems that comply with applicable standards. The anchorage must have the strength capable of supporting a static load, applied in the directions permitted by the system, of at least 5,000-lbf (22kN) in the absence of certification.
4. The user shall be equipped with a means of limiting the maximum dynamic forces exerted on the user during the arrest of a fall to a maximum of 8 kN (1800-lbf). In the EU these forces must be limited to 6 kN (1350-lbf).
5. Use of this product must be approved by an engineer or other qualified person (as defined by OSHA 29 CFR 1926.32 (m)) to be compatible with any and all structural & operational characteristics of the selected installation location and system to be connected to this anchorage connector.
6. The anchorage connector must be inspected prior to each use for wear, damage, and other deterioration. If defective components are found, the anchorage connector must be immediately removed from service in accordance with applicable standards and the manufacturer's inspection requirements.
7. The anchorage connector should be positioned in such a way that minimizes the potential for falls and the potential fall distance during use. The complete fall arrest system must be planned (including all components, calculating fall clearance, and swing fall) before using.
8. A rescue plan, and the means at hand to implement it, must be in place that provides the prompt rescue of users in the event of a fall, or assures that users are able to rescue themselves.
9. After a fall occurs, the anchorage connector must be removed from service and destroyed immediately.

USE LIMITATIONS: This anchorage connector has been tested in compliance with the requirements of ANSI/ASSE Z359.7. Compliance testing covers only the hardware and does not extend to the anchorage and substrate to which the anchorage connector is attached. The anchorage connector must not be used outside its limitations or for any purpose other than that for which it is intended. If this anchorage connector is used differently from these instructions, it must be designed, installed, and used under the supervision of an engineer according to ANSI Z359.6 and local building codes as applicable.

1. The anchorage connector is designed for single user.
2. The anchorage connector may be pulled in any direction shown in the PROPER LOADING diagram.
3. The anchorage connector is designed to be used in temperatures ranging from -40°F to +130°F (-40°C to +54°C).
4. Do not expose the anchorage connector to chemicals or harsh solutions which may have a harmful effect.
5. Do not alter or modify this product in any way.
6. Caution must be taken when using any component of a fall arrest, work positioning, rope access, or rescue system near moving machinery, electrical hazards, sharp edges, or abrasive surfaces, as contact may cause equipment failure, personal injury, or death.
7. Do not use/install equipment without proper training by a "competent person" as defined by OSHA 29 CFR 1926.32(f).
8. Do not remove the labeling from this product.
9. Additional requirements and limitations may apply depending on anchorage type and fastening option utilized for installation. All placements must be approved by an engineer or other qualified person.
10. This anchorage connector should not be used as part of a horizontal lifeline system that has not been designed and/or approved to be used with 5,000-lbf anchorage connectors.
11. The anchorage connector should only be used as intended (see PURPOSE).
12. If attaching the anchorage connector to the support structure by methods other than instructed, the attachment must be certified by a qualified person to meet the requirements of the system that will connect to the anchorage connector.

COMPATIBILITY LIMITATIONS

Anchorage connector must only be coupled to compatible connectors. OSHA 29 CFR 1926.502 and 1910.140 prohibits snaphooks from being engaged to certain objects unless two requirements are met: it must be a locking type snaphook, and it must be "designed for" making such a connection. "Designed for" means that the manufacturer of the snaphook specifically designed the snaphook to be used to connect to the equipment listed. The following connections must be avoided, because they can result in rollout* when a nonlocking snaphook is used:

- Direct connection of a snaphook to horizontal lifeline.
- Two (or more) snaphooks connected to one D-ring.
- Two snaphooks connected to each other.
- A snaphook connected back on its integral lanyard.
- A snaphook connected to a webbing loop or webbing lanyard.
- Improper dimensions of the D-ring, rebar, or other connection point in relation to the snaphook dimensions that would allow the snaphook keeper to be depressed by a turning motion of the snaphook.

***Rollout: A process by which a snaphook or carabiner unintentionally disengages from another connector or object to which it is coupled. (ANSI Z359.0-2007)**

MAINTENANCE, CLEANING AND STORAGE

Cleaning periodically will prolong the life and proper functioning of the product. The frequency of cleaning should be determined by inspection and by severity of the environment. Clean with compressed air and/or a stiff brush using plain water or a mild soap and water solution. Do not use any corrosive chemicals that could damage the product. Wipe all surfaces with a clean, dry cloth and hang to dry, or use compressed air. When not in use, store anchorage connectors in a cool, dry, clean environment, out of direct sunlight and free of corrosive or other degrading elements.

Werner Co.
93 Werner Road
Greenville, PA 16125
1 (888) 523-3371 / www.wernerco.com
P/N 105545-02 Rev D 4/21

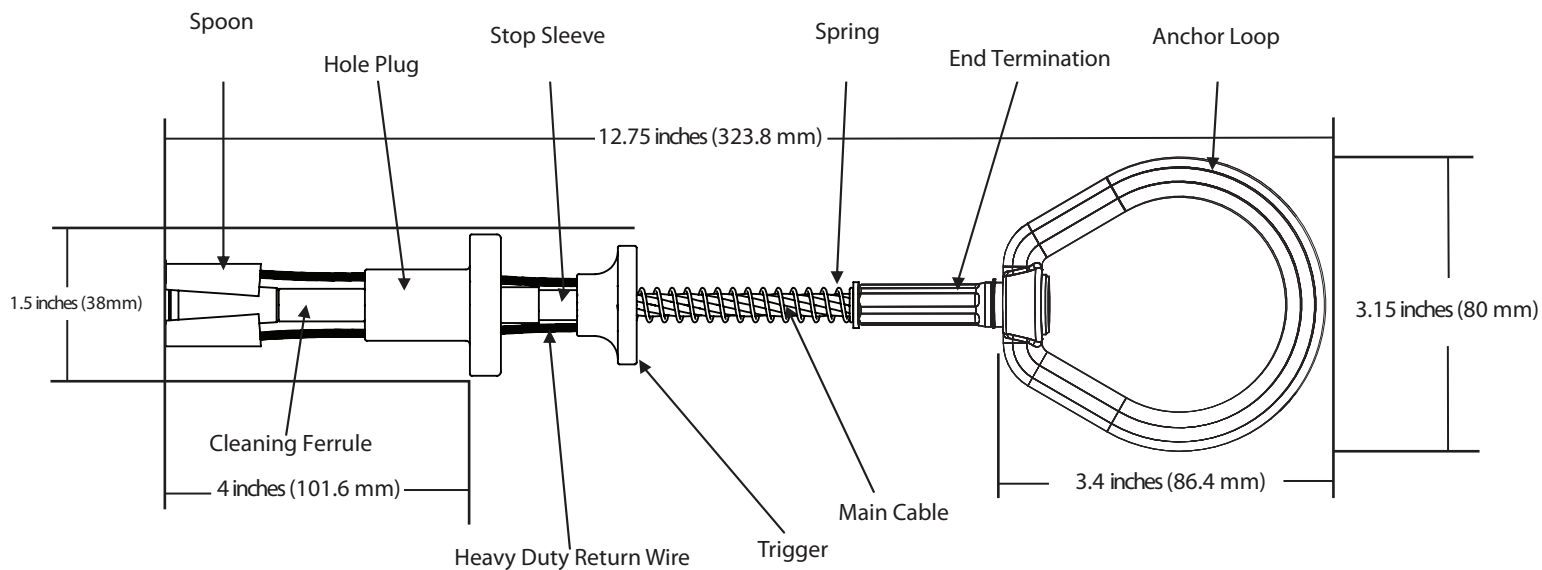

PERFORMANCE:
Minimum Breaking Strength (MBS): 5000-lbf (22kN)
Maximum Capacity: One worker, when used as a single point anchorage connector for personal fall arrest or restraint system

DIMENSIONS:
Weight: .44-lbs (200g)
Length: 11.5 inches (293mm)
Diameter: .75 inch (19mm)

REGULATORY COMPLIANCE:
 ANSI Z359.7-2019, ANSI Z359.18 Type A
 OSHA 29 CFR 1926.502,
 OSHA 29 CFR 1910.140

COMPONENT MATERIALS:
Aluminum: Trigger
Aircraft Cable: Main Cable, Activator Wire
Stainless Steel: Cone, Spoons, Stop Sleeve, End Termination, Cleaning Ferrule
Zinc Plated Steel: Spring, Hole Plug, Anchor Loop

DRILLING & INSTALLATION INSTRUCTIONS:

1. Drill a .75 inch (20mm) diameter hole at least 3.5 inches (89mm) deep. The drilled hole must be straight and perpendicular to the surface. Make sure the hole is of uniform diameter and free of peaks and valleys on the inner wall.
2. Blow hole clean with compressed air.
3. Always inspect the hole carefully when reusing a previously drilled hole.
4. When placing anchor, place your thumb inside the anchor loop and your first two fingers around the trigger. Squeeze fingers and thumb together till the trigger and spring fully compress.
5. Insert unit at least 3.25 inches (83 mm) deep into hole and release the trigger. Do not force.
6. Set the unit with a slight tug on the anchor loop.

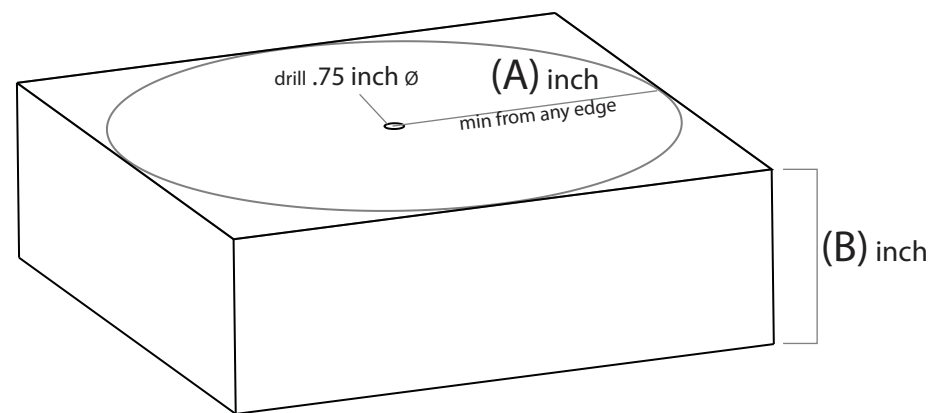

HOLE DRILLING REQUIREMENT CHART	
(A) Inches Minimum distance from edge/corner	(B) Inches Concrete thickness
6 inches (15.3 cm)	12 inches (30.5 cm)
12 inches (30.5 cm)	5 inches (12.7 cm)

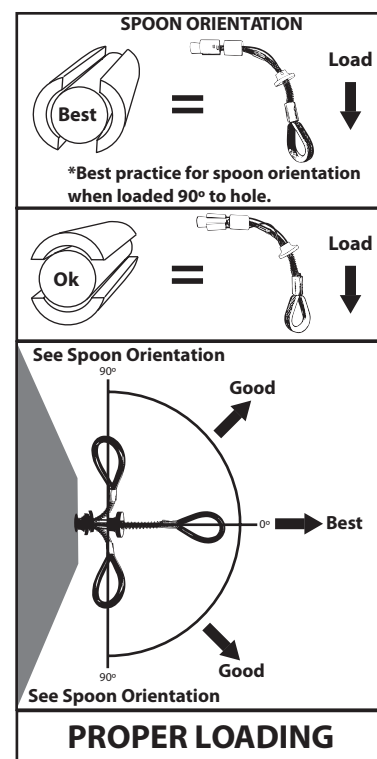

REMOVAL INSTRUCTIONS:

1. When removing anchor, place your thumb inside the anchor loop and your first two fingers around the trigger. Squeeze fingers and thumb together until the trigger and spring fully compress.
2. While squeezing the trigger, pull the anchor out of the hole.
3. If the anchor becomes stuck, lightly tap the hole plug while squeezing on the trigger to release.
4. If tool was required to remove the anchorage, inspect thoroughly for damage after removal. If damage is found, remove from service and destroy immediately.

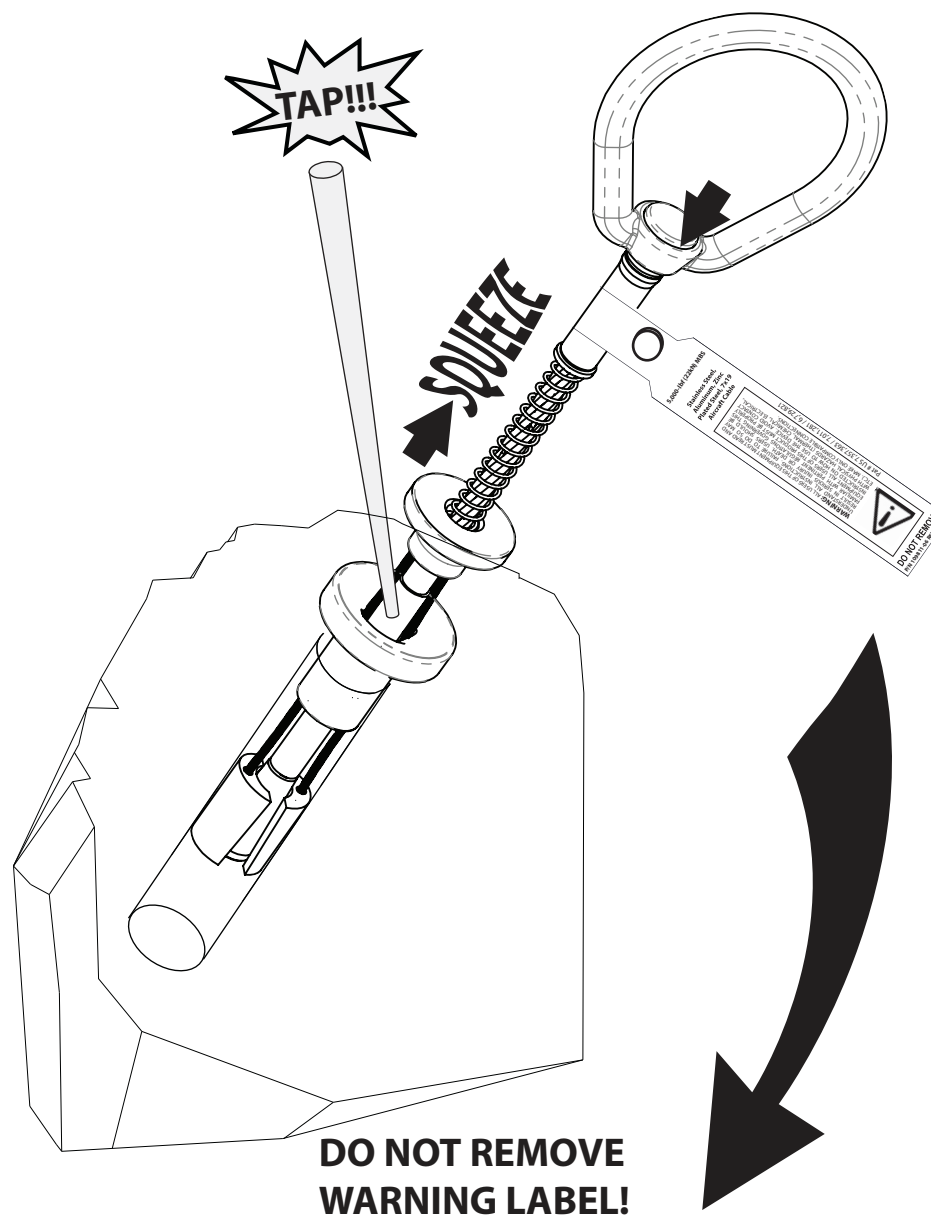

DO NOT REMOVE WARNING LABEL!

WARNING: ALL USERS OF THIS EQUIPMENT MUST READ AND UNDERSTAND ALL INSTRUCTIONS. FAILURE TO DO SO MAY RESULT IN SERIOUS INJURY OR DEATH. USERS SHOULD BE FAMILIAR WITH FEDERAL REGULATIONS GOVERNING THIS EQUIPMENT. ALL USERS OF THIS PRODUCT MUST PROMPTLY INSTRUCTED ON HOW TO USE THE DEVICE. ALWAYS CONSULT WITH PHYSICAL SCIENCES, CHEMICAL, MECHANICAL, ELECTRICAL, ETC., MAKE ONLY COMPARABLE CONNECTIONS.

PH: US 7337363 / 7281281 / 6272921

WERNER

Compliance: OSHA 29 CFR 1926.502, OSHA 29 CFR 1910.140, ANSI Z359.18 Type A, ANSI Z359.7119

Removable Fork
 Model No. 115000
 Batch No. 0000
 11/18/19 3/23/17
 INSPECT BEFORE USE

May be used as an anchor point for a leading edge restraint system. See optional anchor points below for example. The use of two anchors is not required for leading edge restraint systems unless otherwise specified by the manufacturer.

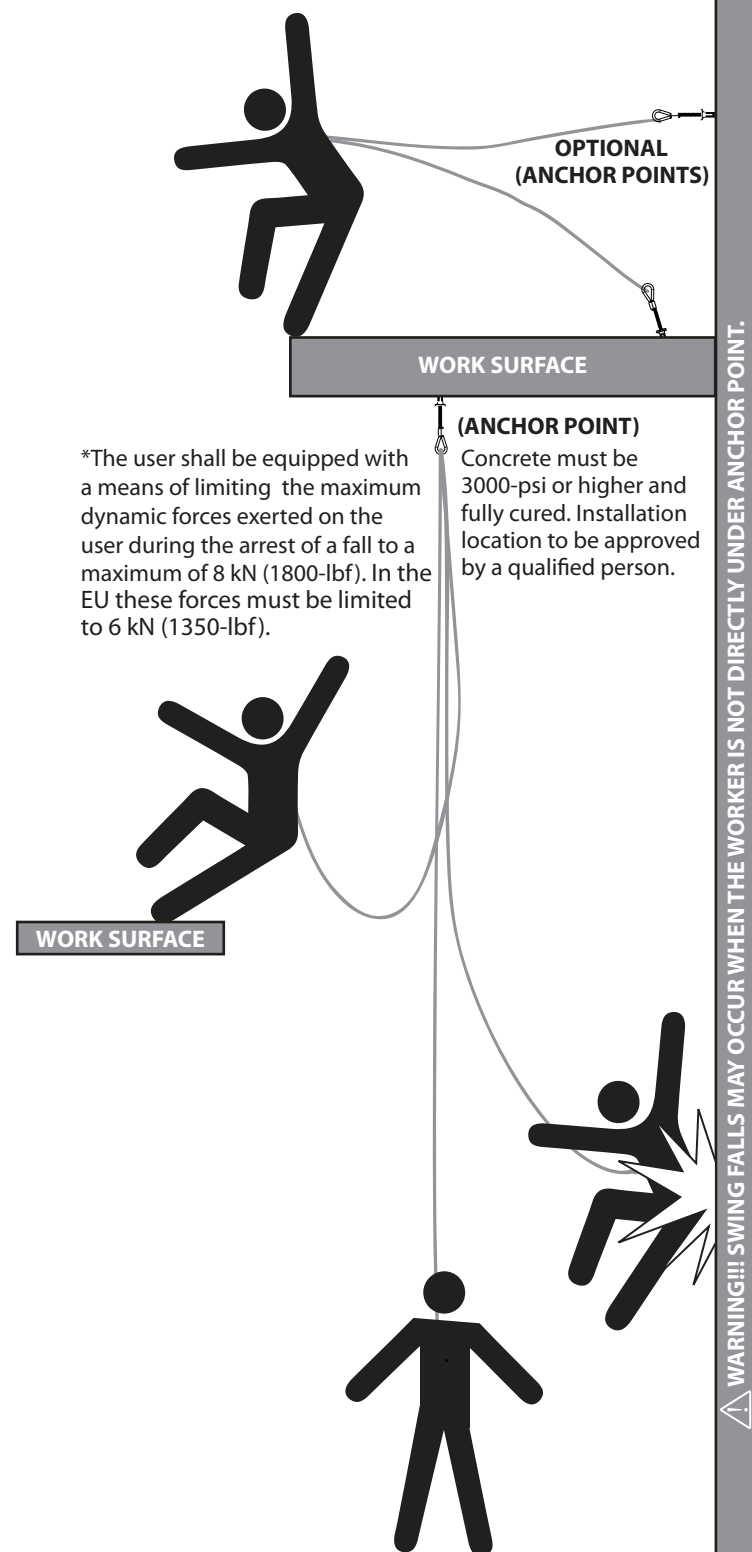

MINIMUM CLEARANCE 2 feet (.6m)

DECK/FLOOR/GROUND LEVEL

All products subjected to fall arresting forces should be removed from service immediately!

WARNING!! SWING FALLS MAY OCCUR WHEN THE WORKER IS NOT DIRECTLY UNDER ANCHOR POINT.