

SH. 1  
OF 1

CAT NO

665H

CUSTOMER DIMENSIONS

DO NOT  
SEPARATE  
PRINT FROM  
WORK

LOT NO

OPER

TOOLS

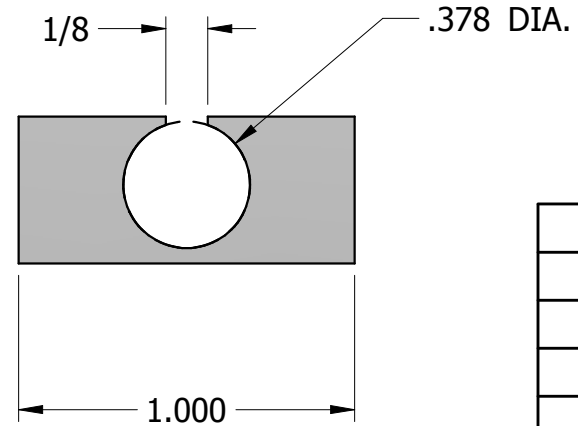
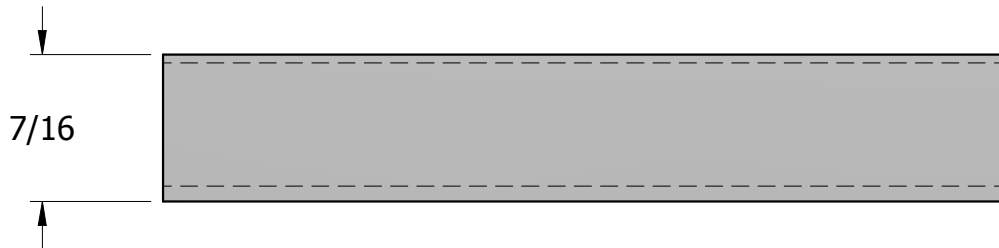
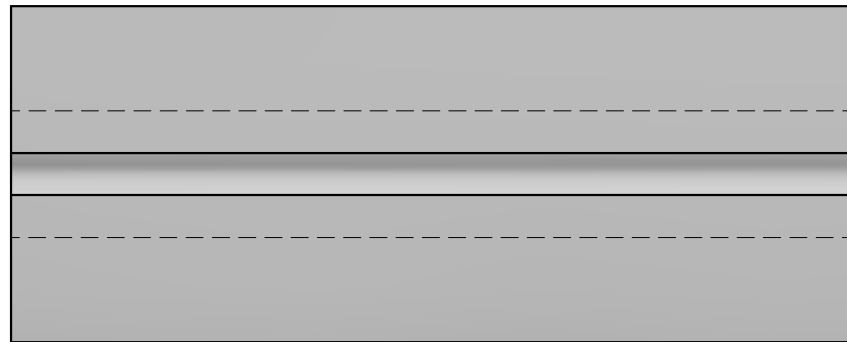

REV	DESCRIPTION	DATE	BY
-----	-------------	------	----

DR	R.C.	CHK	DATE
----	------	-----	------

DIAL TEST INDICATOR HOLDER  
FOR OFFSET ARM

THE L.S. STARRETT CO.  
ATHOL, MASS.

FRACTIONAL TOLERANCE +- 1/64 UNLESS OTHERWISE NOTED