

How to select tool holding

B

1 Select a coupling size

- Turn to the ordering page and select the right coupling size

2 Select clamping unit

- Use the programme overview to choose a holder based on machine type.

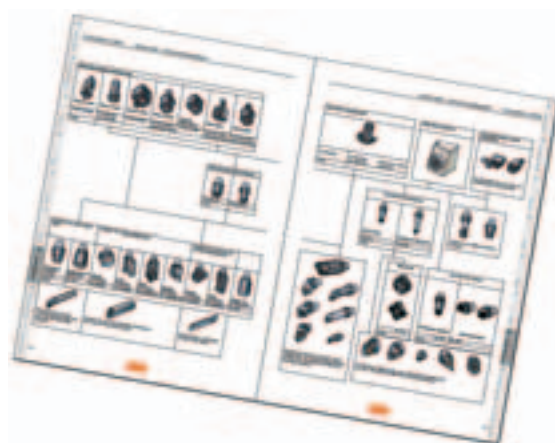

C

3 Choose modular SL-system or integral cutting units

G

4 Add extension if necessary

- Add extensions where needed to complete gauge length requirements. Use the programme overview to find suitable extension.



H



For more technical information, see our Metalcutting Technical guide

Symbols for page references:



How to choose tool, overview



Tool holding Systems, overview



Spare parts/accessories



Conversion table, formulas and definitions

J

TOOLING SYSTEMS

Tooling guide

Turning centres

G10

Products

For turning centres - non rotating tools

Coromant Capto®	G4
Tool holder overview	G6
Manual clamping units	G11
Automatic clamping units	G27
Boring bar adaptor	G52
Extension/reduction adaptors	G54
Coromant Capto® short adaptor for exchangeable head	G57
ER collet chuck adaptor, short	G58
Tap adaptor	G59

Spare parts and accessories

G61

CoroTurn® SL flexible system

I1

Tools for Multi-task machining

H1

Tooling systems for rotating

See Main catalogue for milling, drilling and boring tools.

Coromant Capto®

Tooling system



Coromant Capto is widely used in turning centres with manual clamping via a CAM-shaft actuated clamp set. Quick changing of tools maximizes machine efficiency with an average of 25% more time for producing chips.

Turret evolution

Turrets have evolved into two main groups where Coromant Capto applications are typical for both static and driven applications.



CDI - Coromant Capto Disc Interface

New solution to replace VDI turrets

Same adaptors fit multiple machine brands and models

Cam actuation screw inside turret



CBI - Coromant Capto 'Bolt on' Interface

'Bolt on' solution

Unique hole pattern for each machine brand

Cam actuation screw-in bolt on unit



Coromant Capto® can be integrated directly into the turret using the standard clamping mechanism.



Standard lathes can easily be converted to Coromant Capto® quick-change tools using standard clamping units.

Coromant Capto® Quick Change

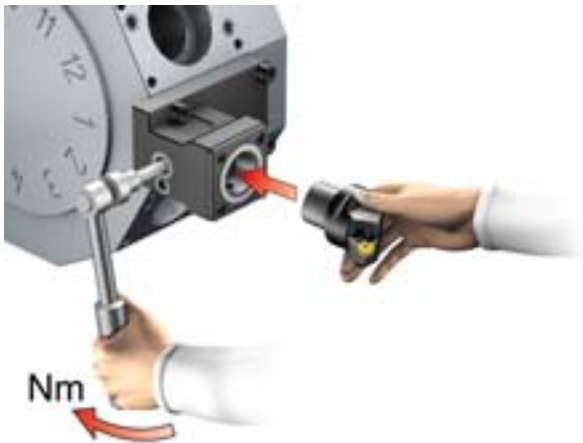

A quick change system offers:

- Fast and efficient tool changing
- Insert changing outside the machine
- Pre-setting possibilities

Less than 180° for clamping and unclamping

- Camshaft actuated



The most economical system for:





- Small batch production, quicker set-up times
- Operations with frequent insert changes

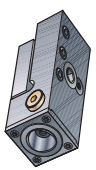
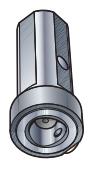
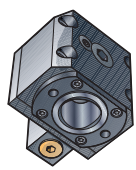
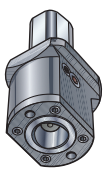
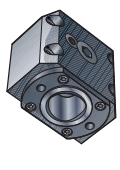
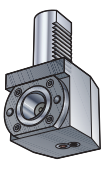
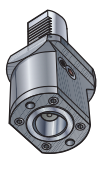

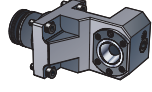

Vertical automation

Large components dictate vertical ram solutions where tool capacity has long been a major challenge. But Coromant Capto either: hydraulic automatic tool change (ATC), or dedicated manual clamping units, are now most commonly used.

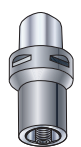

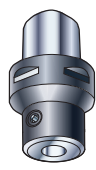
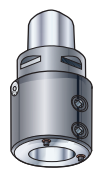
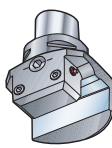

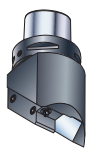
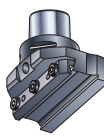

Manually operated clamping units							
							
Square shank	Round shank	Square shank	Round shank	Special applications	VDI angled	VDI straight	VDI Dovetail
Cx-R/LC2085	Cx-NC2000 Cx-NC3000	Cx-R/LC2080	Cx-R/LC2045/ 2055/2065	Cx-R/LC2090	DIN 69880 Cx-R/LC2030/ 2040/2050/2060	DIN 69880 Cx-R/LC2030/ 2040/2050/2060	DIN 69881 Cx-R/LCI 115/ Cx-R/LCI 140
Page G13	G12	G14	G15	G16	G18	G18	G25

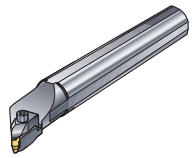
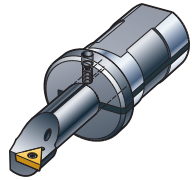
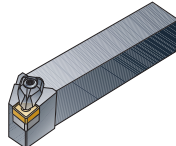
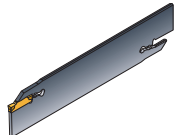
			<div style="border: 1px solid black; padding: 5px; text-align: center;"> Extension/reduction adaptors </div>  				
CDI internal	CDI external	CDI adaptors for square shank, round shank and parting blades					
Cx-R/LCI80	Cx-R/LCE80	ASH-TNE/ABB-TNE/ABP-TNE	<div style="display: flex; justify-content: space-around;"> Cx-391.01 Cx-391.02 </div>				
Page G20	G22	G24	<div style="display: flex; justify-content: space-around;"> Page G54 G55 </div>				

Adaptors for round shank tools		Adaptors for square shank tools				Adaptor for CoroCut® and T-Max Q-Cut® parting blades		HSK adaptors
								
Boring bar adaptor	Boring bar for multi-task machines	Radial mounting	Axial mounting	Axial mounting	Angular mounting	Radial mounting	Axial mounting	Parting blades and shank tools
Cx-131	Cx-131	Cx-ASHA	Cx-ASHR/L	Cx-ASHR/L3	Cx-ASHR/L45	Cx-APBA	Cx-APBR/L	392.419-ASHA/ ASHR/L/ABPR/L
Page G52	H37	H28	H29	H31	H30	H32	H32	H38

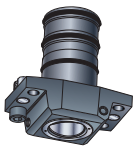
			
Round shank tools, see General turning, Parting and grooving and Threading chapters	Shank tools, see General turning, Parting and grooving and Threading chapters	Parting blades, see Parting and grooving chapter	

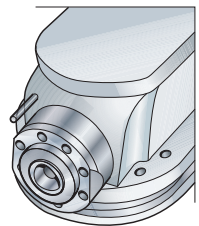
1) For cylindrical bars EasyFix sleeve can be used, see page A320

Automatic clamping units	CDI - Driven toolholders		Multi-task machines	Machine adapted clamping units, driven toolholders and holders for parting blades CBI
				
Cx-NC5010/Cx-NC5110/Cx-NC5210	External Cx-DNE80	Internal Cx-DNI80		Mazac, Mori Seiki, Doosan, Nakamura-Tome, Okuma
Jetbreak™				
Page G29	G23	G23		Page G35

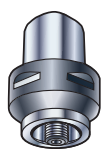

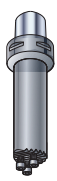

Extension/reduction adaptors	
	
180° rotated polygon	
Cx-391.01R	Cx-391.02R
Page G56	G56

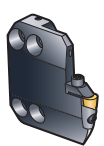
HSK CoroTurn SL adaptors	
	
392.T..SL	392.T..SL70
I106	I106

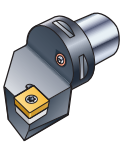
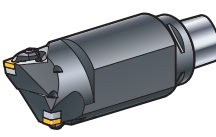
CoroTurn® SL boring bars?	
	
Steel shank	Dampened boring bars
Cx-A570/Cx-570	Cx-A570/Cx-570
Page I57	I58

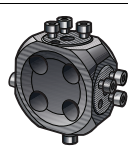
CoroTurn® SL70

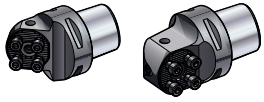
Cx-SL70
Page I100

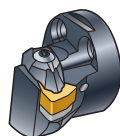
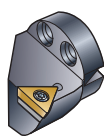
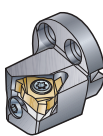
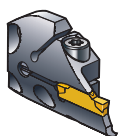
CoroTurn® SL70, cutting heads see CoroTurn SL chapter.

	
External and internal Coromant Capto® cutting units, see General turning, Parting and grooving, Threading and Multi-task machining chapters.	

Mini-turret	CoroTurn® SL system		
			
	Boring bar adaptor	External adaptor	
Cx-A570/Cx-570	Cx-A570/Cx-570	Cx-A570/Cx-570	
			
CoroTurn® SL cutting heads, see CoroTurn SL chapter.			

The manual clamping units

On manually activated units both camshaft, drawbars and centre bolt mechanisms are used. Always use torque wrench when clamping the units.

B

Cam shaft activated drawbar

The movement of the drawbar is generated by a cam acting from the side of the unit which rotates in a slot in the drawbar.

A hexagon key is used to lock/unlock the cutting head (less than a half turn is required).

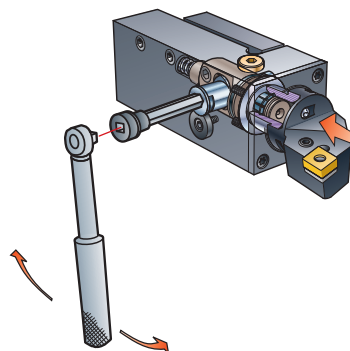

Screw activated drawbar

The movement of the drawbar is controlled by a screw acting from the rear of the unit.

A hexagon key is used to lock/unlock the cutting head (one turn is required).

C

Centre bolt clamping

A rear activated centre bolt is used to clamp/unclamp the cutting head.

A hexagon key is used to lock/unlock the cutting head (six turns are required).

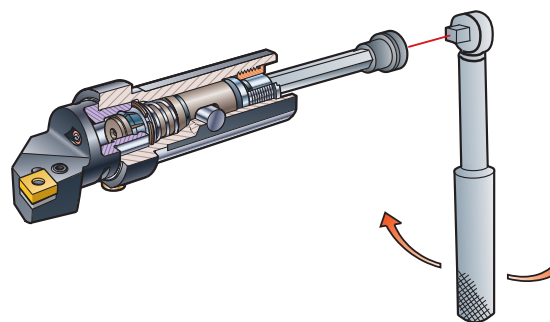

G

Shank type clamping units for conventional turrets

Round shank units for internal operations:

The 2000 type features

- Expandable segmented bushing clamp design.
- Screw activated drawbar.
- Less than 180° for clamping and unclamping

The 3000 type features

- Centre bolt clamping
- 4-5 revs for clamping and unclamping

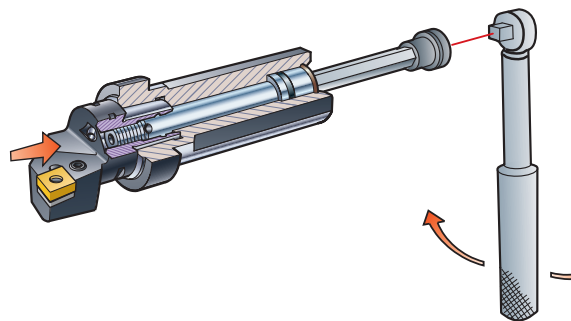

H

Installation is simple

- Both mount in the turret like a standard boring bar.

Shank units for external operations:

Easily adaptable to most machines using 20, 25, 32 or 40 mm square shank tools.

The 2085 type features

- The expandable segmented bushing
- Cam shaft activated drawbar.

Installation is simple

- Remove the square shank tool and machine wedge.
- Slide the Coromant Capto 2085 clamping unit into place and tighten the wedge.

These tools feature

- No special adaptation to tool or turret.
- Through tool coolant.
- Minimum overhang allowing maximum working envelope.
- Same key for clamping external and internal units.
- Adjustable shank length (cut off if necessary).

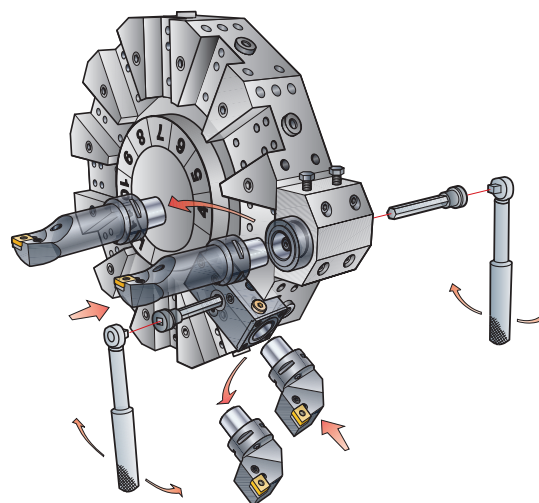

J

Manual clamping units for special applications

The 2090 type clamping unit is designed for special adaptation to the machine.

Design instructions for the application of these units are shown on the ordering page.

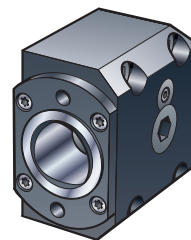

Clamping units for DIN 69880 (VDI) turrets

These tools feature:

- No special adaptation to tool or turret.
- Through tool coolant.
- Minimum overhang allowing maximum working envelope.
- Same key for clamping external and internal units.

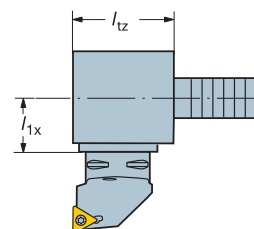
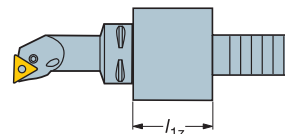

VDI clamping units for external and internal operations

- Expandable segmented bushing clamp design.
- Quick change – 1/2 turn to lock/unlock.
- Same length dimension for corresponding angular l_{1z} and straight l_{1z} units to avoid risk of collision.
- Two different l_{1x} dimensions available on angular units.

CDI - Coromant Capto Disc Interface

- New solution to replace VDI turrets
- Same adaptors fit multiple machine brands and models
- Cam actuation screw inside turret

Tooling alternatives

Conventional turrets

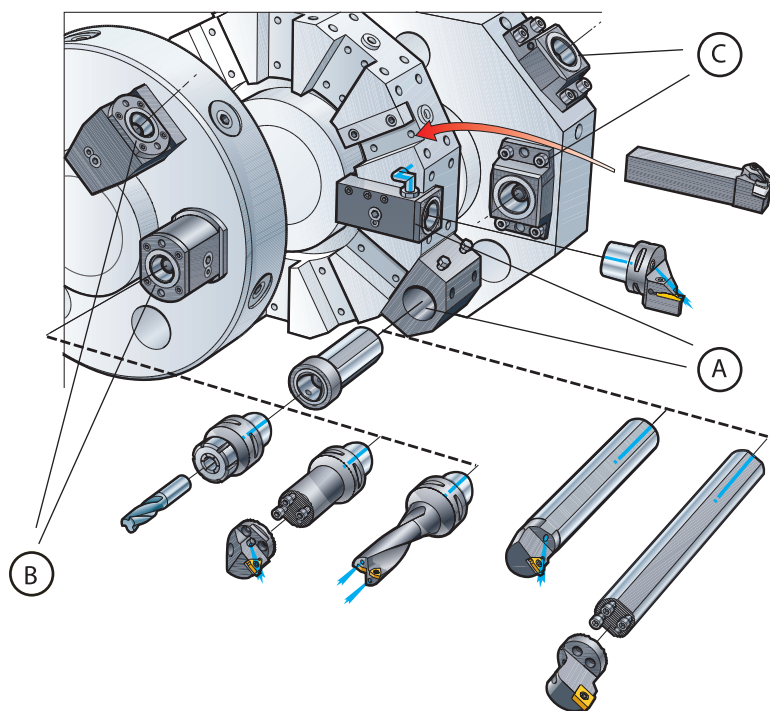

Manually operated Coromant Capto® clamping units

- Camshaft activated
- Screw activated
- Centre bolt activated

A Shank type clamping units

- Square and round shank tools as well as Coromant Capto units for external and internal operations

B Coromant Capto® clamping units for DIN 69880 (VDI) turrets

- Angled and straight clamping units for external and internal operations

C Hydraulically operated clamping units

- Manual push-button tool changing
- Fully automatic tool changing possible

How to choose shank type clamping units 2000, 3000 and 2085

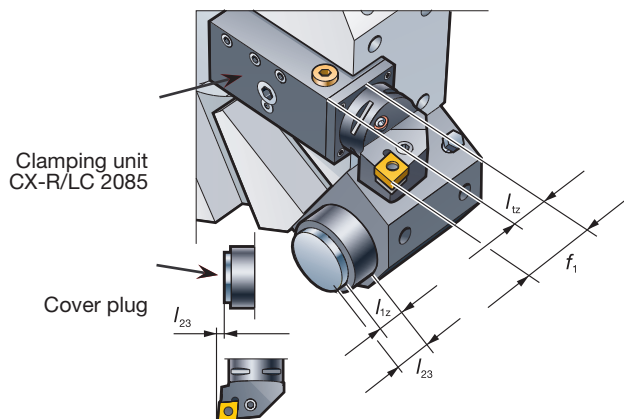
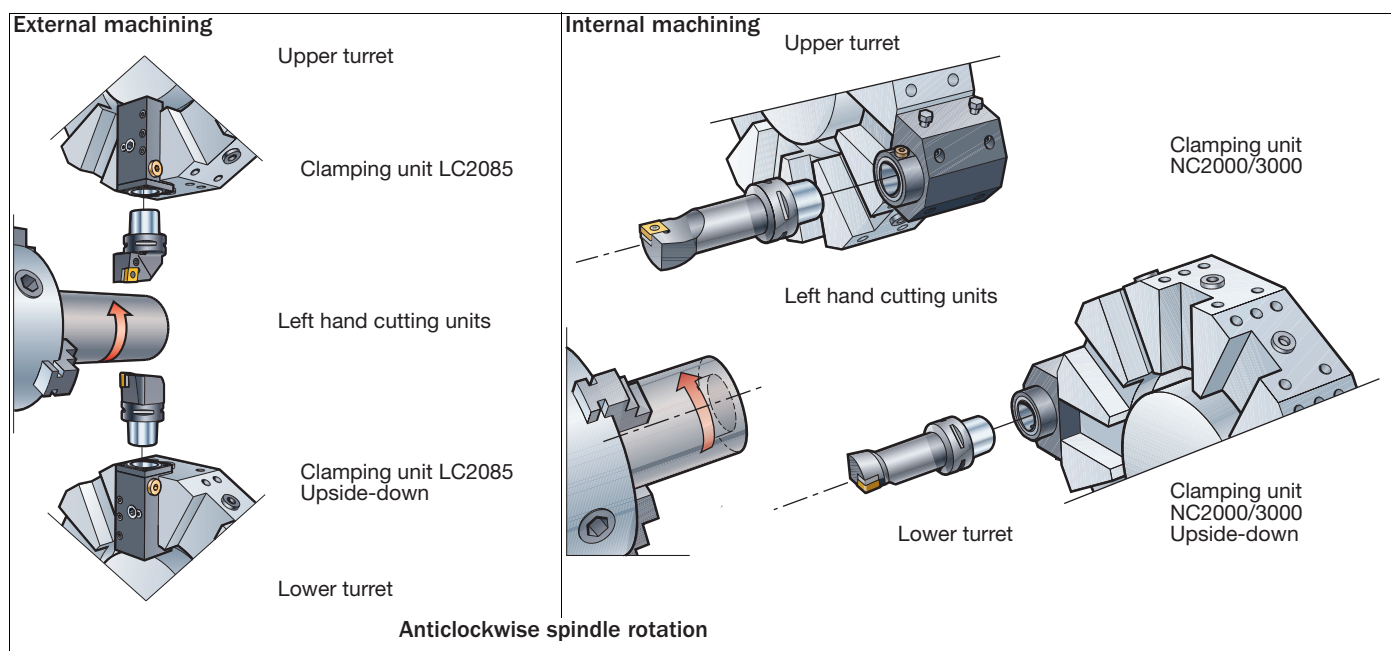
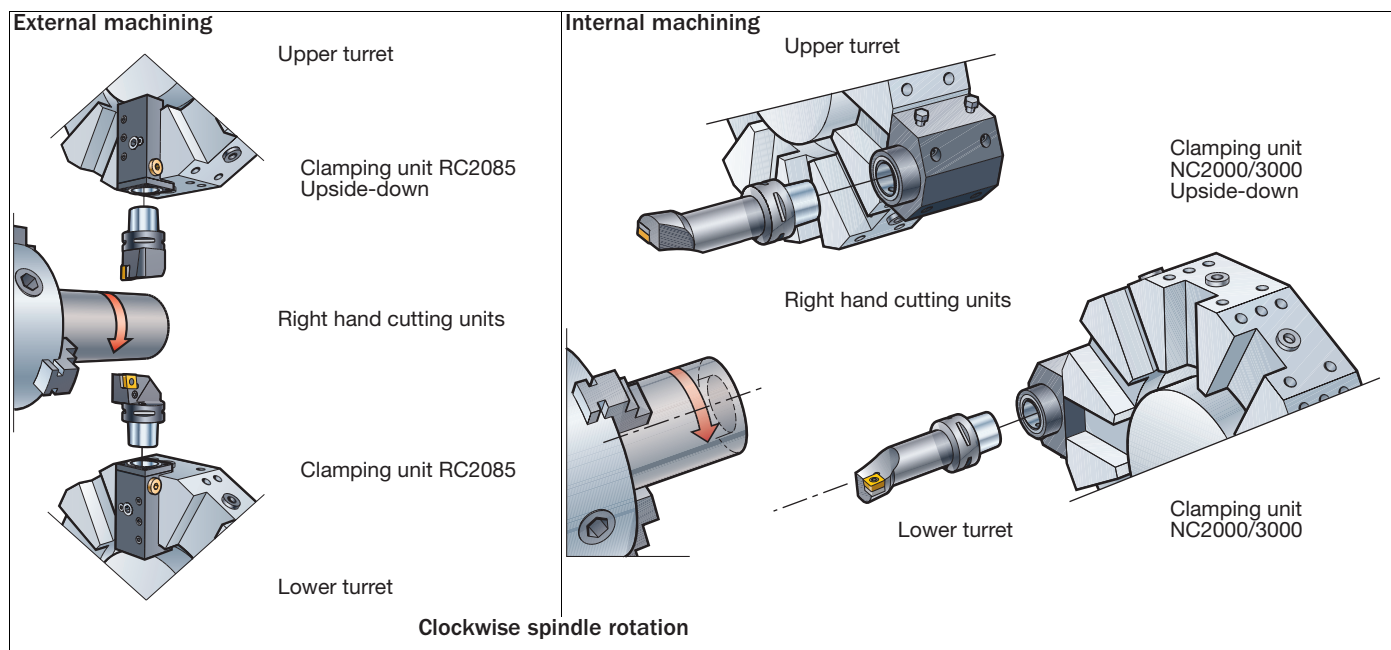

Application guide for type 2000 and 3000

A cover plug (CX-CP-01) must be used in a clamping unit when no cutting unit is installed. As can be seen from the diagram and table there is no risk of collision between the workpiece and cover plug during facing operations using clamping unit CX-R/LC 2085.

Dimensions, mm (inch)	f_1	l_{12}	l_{12}	l_{23}
C3-R/LC 2085	22 (.87)	18 (.71)	-	-
C3-NC2000/3000	-	-	18 (.71)	21 (.83)
C4-R/LC 2085	27 (1.06)	23 (.91)	-	-
C4-NC2000/3000	-	-	20 (.79)	24 (.94)
C5-R/LC 2085	35 (1.38)	32 (1.26)	-	-
C5-NC2000/3000	-	-	24 (.94)	29 (1.14)

Manually operated clamping units

Round shank

Segment clamping

Turret type

Type 2000

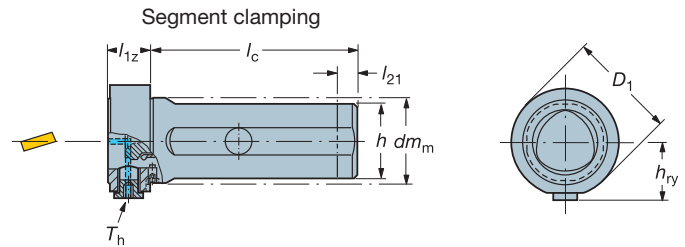
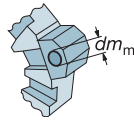
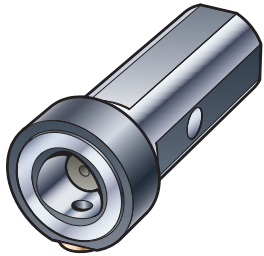

B

C

Note: Maximum coolant pressure is 80 bar (PSI 1160)

Metric version

Turret type			Dimensions, mm						
dm_m , size, mm	Coupling size	Ordering code	D_1	h	h_{ry}	l_c	l_{12}	l_{21}	T_h
32	C3	C3-NC2000-08018-32	45.5	30	26	80	18		G1/8
40	C4	C4-NC2000-10020-40	51.5	37	28	100	20	8	G1/8
50	C4	C4-NC2000-12020-50	51.5	47	28	120	20	28	G1/8
50	C5	C5-NC2000-12024-50	61.5	47	33	120	24		G1/8
60	C5	C5-NC2000-14024-60	61.5	57	33	140	24	20	G1/8

Inch version

Turret type			Dimensions, inch						
dm_m , size, inch	Coupling size	Ordering code	D_1	h	h_{ry}	l_c	l_{12}	l_{21}	T_h
1.250	C3	C3-NC2000-08018-A20	1.790	1.180	.930	3.150	.710		G1/8
1.500	C4	C4-NC2000-10020-A24	2.028	1.457	1.024	3.937	.787	.315	G1/8
2.000	C4	C4-NC2000-12020-A32	2.028	1.850	1.004	4.724	.787	1.102	G1/8
2.000	C5	C5-NC2000-12024-A32	2.421	1.850	1.220	4.724	.945		G1/8

G

Centre bolt activated

Turret type

Type 3000

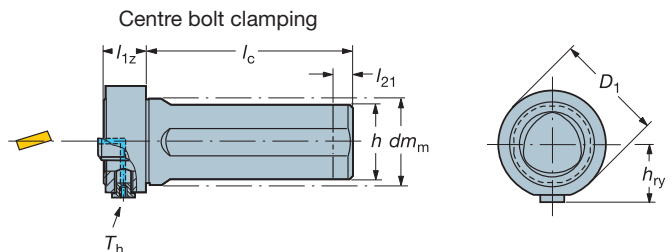
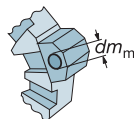
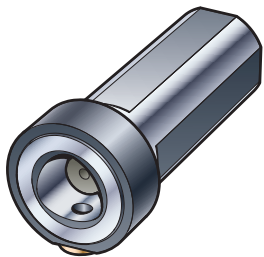

H

Note: Maximum coolant pressure is 80 bar (PSI 1160)

Metric version

Turret type			Dimensions, mm						
dm_m , size, mm	Coupling size	Ordering code	D_1	h	h_{ry}	l_c	l_{12}	l_{21}	T_h
32	C3	C3-NC3000-08018-32	45.5	30	26	80	18		G1/8
40	C3	C3-NC3000-10018-40	45.5	37	26	100	18	20	G1/8
40	C4	C4-NC3000-10020-40	51.5	37	28	100	20	10	G1/8
50	C5	C5-NC3000-12024-50	61.5	47	33	120	24	20	G1/8

Inch version

Turret type			Dimensions, inch						
dm_m , size, inch	Coupling size	Ordering code	D_1	h	h_{ry}	l_c	l_{12}	l_{21}	T_h
1.250	C3	C3-NC3000-08018-A20	1.791	1.181	.933	3.150	.709		.000
1.500	C4	C4-NC3000-10020-A24	2.028	1.378	1.024	3.937	.787	.394	.000
2.000	C4	C4-NC3000-12024-A32	2.028	1.850	1.004	4.724	.787	1.181	.000

J

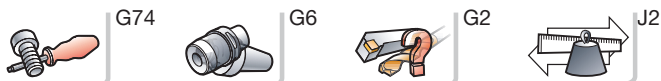

Manually operated clamping units

Square shank
Camshaft activated

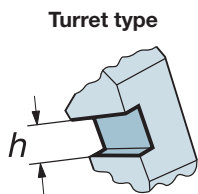
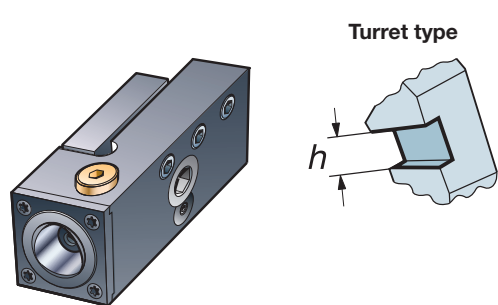

Type 2085
Inch version

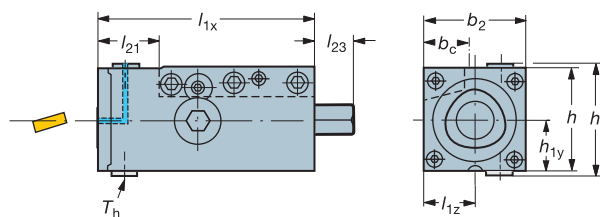

Metric version

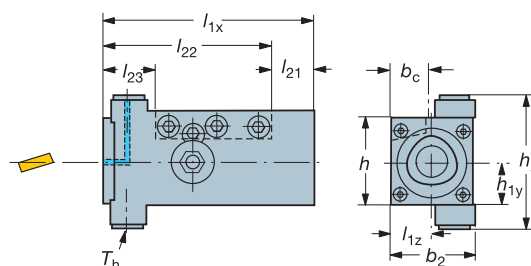

Right hand style shown.

Note: Maximum coolant pressure is 80 bar (PSI 1160)

Metric version

Turret type			Dimensions, mm										
h, size, mm	Coupling size	Ordering code	bc ¹⁾	b ₂	h _{1y}	h ₂	l _{1x}	l _{1z}	l ₂₁ ²⁾	l ₂₂	l ₂₃	Th	
40	C3	C3-R/LC2085-4038M	20	38	20	62	95	19	16.5	78.5	25	G1/8	
50	C4	C4-R/LC2085-5048	25	48	25	54	125	24	24	101	30.5	G1/8	
64	C5	C5-R/LC2085-6464	32	64	32	68	145	32	27	118	36	G1/8	

Inch version

Turret type			Dimensions, inch										
h, size, inch	Coupling size	Ordering code	bc	b ₂	h _{1y}	h ₂	l _{1x}	l _{1z}	l ₂₁	l ₂₂	l ₂₃	Th	
2.000	C4	C4-R/LC2085-24102-16M	1.000	1.890	1.000	2.323	5.035	0.9449	1.000	4.035	1.201	G1/8	
2.500	C5	C5-R/LC2085-32130-20M		2.520	1.250	2.835	5.138	1.2598			1.472	G1/8	

1) Depth of shank adaptor

2) The maximum length that can be cut off

Coromant Capto® tightening torque:

Manual clamping units and driven tool holders with camshaft mechanism

Coupling size	Torque (Nm)	ft-lbs
C3	35	25.8
C4	50	36.9
C5	70	51.2
C6	90	66.4
C8	130	95.9
C10	285	210

Coromant Capto® tightening torque:

Manual clamping units type NC2000 and NC3000

Coupling size	Torque (Nm)	ft-lbs
C3	35	25.8
C4	50	36.9
C5	70	51.6

For torque wrenches, see page G65



G73



G6



G2



J2

Manually operated clamping units

Square shank

Camshaft activated

B

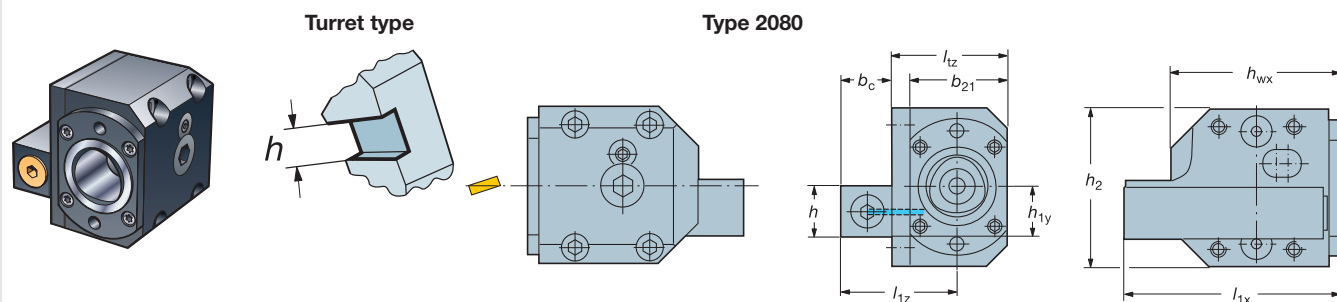

C

Note: Maximum coolant pressure is 80 bar (PSI 1160)

Right hand style shown.

Metric version

Turret type			Dimensions, mm							
<i>h</i> , size, mm	Coupling size	Ordering code	<i>b_c</i>	<i>b₂₁</i>	<i>h_{wx}</i>	<i>h_{1y}</i>	<i>h₂</i>	<i>l_{1x}</i>	<i>l_{tz}</i>	<i>l_{1z}</i>
25	C4	C4-R/LC2080-59110A	26	48	86	25	77	110	57	59
32	C5	C5-R/LC2080-77110A	33.5	64	100	32	92	110	75.5	77
40	C6	C6-R/LC2080-93140	40		122	40	105	140	95	93

G

Inch version

Turret type			Dimensions, inch							
<i>h</i> , size, inch	Coupling size	Ordering code	<i>b_c</i>	<i>b₂₁</i>	<i>h_{wx}</i>	<i>h_{1y}</i>	<i>h₂</i>	<i>l_{1x}</i>	<i>l_{tz}</i>	<i>l_{1z}</i>
1.250	C5	C5-R/LC2080-76118-20A	1.310	2.520	3.940	1.250	3.230	4.640	2.99	2.94

H

Coromant Capto® tightening torque:

Manual clamping units and driven tool holders with camshaft mechanism

Coupling size	Torque (Nm)	ft-lbs
C3	35	25.8
C4	50	36.9
C5	70	51.2
C6	90	66.4
C8	130	95.9
C10	285	210

I

For torque wrenches, see page G65

J

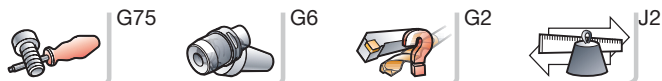

Manually operated clamping units

Round shank

Camshaft activated

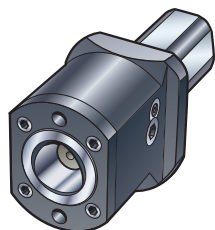

Turret type

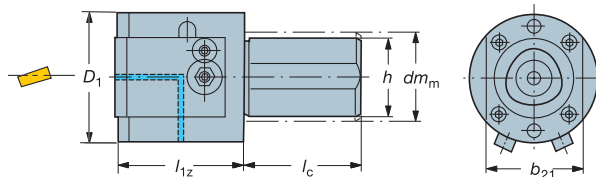
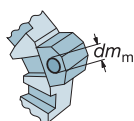

Right hand style shown.

Note: Maximum coolant pressure is 80 bar (PSI 1160)

Left hand: hexagon clamping socket on opposite side of the tool.

Metric version

Turret type			Dimensions, mm				
dm_m , size, mm	Coupling size	Ordering code	D_1	b_{21}	h	l_c	l_{1z}
28	C4	C4-R/LC2045-00075M	67	48	37	81	75
35	C5	C5-R/LC2055-00085M	82	64	47	100	85
44	C6	C6-R/LC2065-00095	105	84	57	120	95

Inch version

Turret type			Dimensions, inch				
dm_m , size, inch	Coupling size	Ordering code	D_1	b_{21}	h	l_c	l_{1z}
1.260	C5	C5-R/LC2055-00085-32M	3.230	2.520	1.850	4.000	3.350
1.575	C6	C6-R/LC2065-00095-40	4.130	3.310	2.360	4.720	3.740

Coromant Capto® tightening torque:

Manual clamping units and driven tool holders with camshaft mechanism

Coupling size	Torque (Nm)	ft-lbs
C3	35	25.8
C4	50	36.9
C5	70	51.2
C6	90	66.4
C8	130	95.9
C10	285	210

For torque wrenches, see page G65



G77



G6



G2

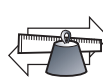

J2

Manually operated clamping units

For special applications

Camshaft activated

B

Type 2090

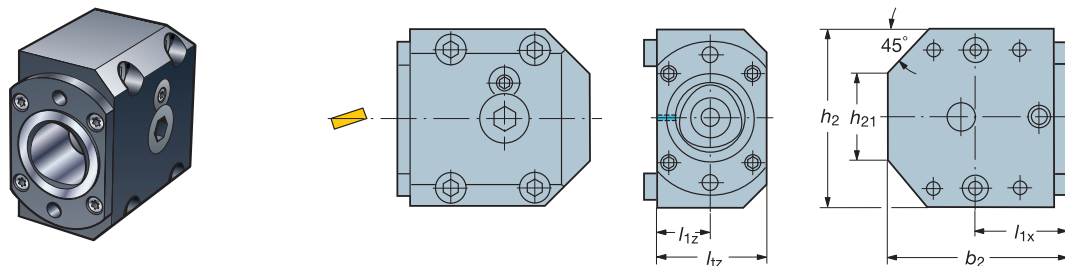

Note: Maximum coolant pressure is 80 bar (PSI 1160)

Right hand style shown.

C

Metric version

Coupling size	Ordering code	Dimensions, mm					
		b_2	h_2	h_{21}	l_{1x}	l_{tz}	l_{1z}
C3	C3-R/LC2090-19039M	73	54	30	39	38	19
C4	C4-R/LC2090-24043A	86	77	38	43	48	24
C5	C5-R/LC2090-32048A	100	92	44	48	64	32
C6	C6-R/LC2090-42060	122	105	37	60	84	42
C8	C8-R/LC2090-50088	146	133	133	88	100	50

Note! Tighten the screw with a torque wrench. Information on page G65.

G

Design instructions for application of clamping unit RC/LC 2090

Material hardness min. 270 HB

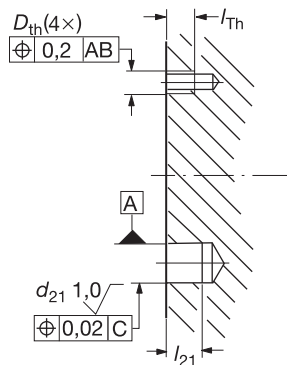

Front of clamping unit

Cutting height

Coolant outlet

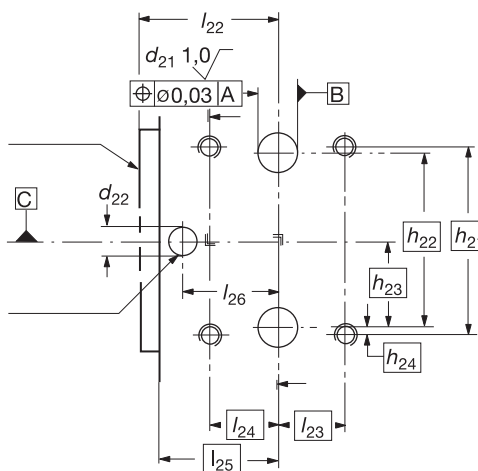

Right hand style shown

H

I

Clamping unit	Dimensions, mm													
	d_{21} H7	d_{22}	h_{21}	h_{22}	h_{23}	h_{24}	l_{21} min	l_{22}	l_{23}	l_{24}	l_{25}	l_{26}	l_{Th} min	D_{Th}
C3-R/LC2090-19039M	12	5	42	39	19.5	1.5	8.5	39	19	19	33.5	28	7.5	M6
C4-R/LC2090-24043A	16	7	60	55	27.5	2.5	11	43	19	19	36.5	30	11	M8
C5-R/LC2090-32048A	20	7	70	62	31	4	12	48	21	21	39.5	33	13	M10
C6-R/LC2090-42060	25	10	82	71	35.5	5.5	20	60	24.5	24.5	50.5	41	12	M10
C8-R/LC2090-50088	32	11	110	92	46	9	20	88	43	43	76	63	14.5	M12

J



How to choose VDI clamping units

External machining

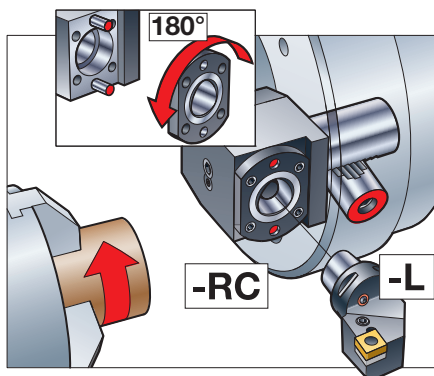
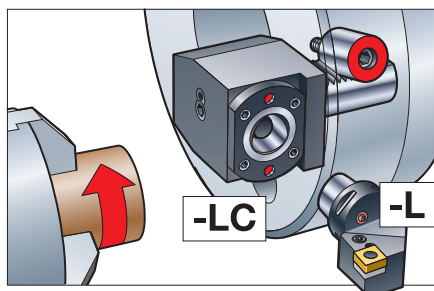

Clockwise spindle direction

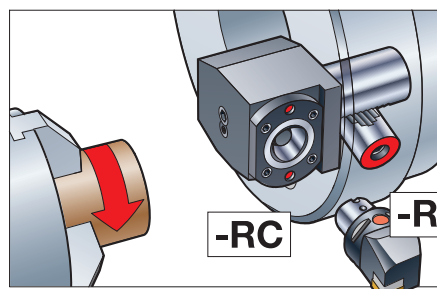
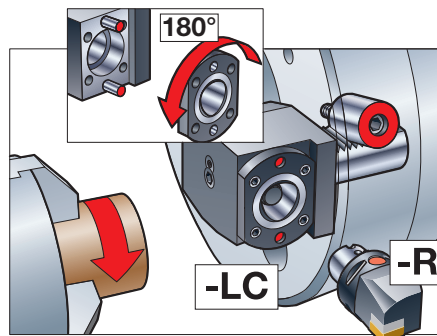

Anti-clockwise spindle direction

Note: Polygon sleeve must be turned 180°. See Metal cutting technical guide.

Note: Polygon sleeve must be turned 180°. See Metal cutting technical guide.

Internal machining

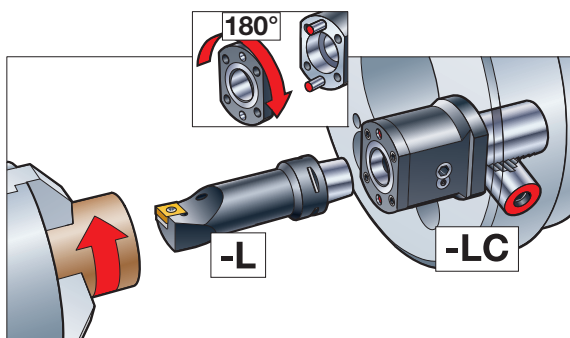
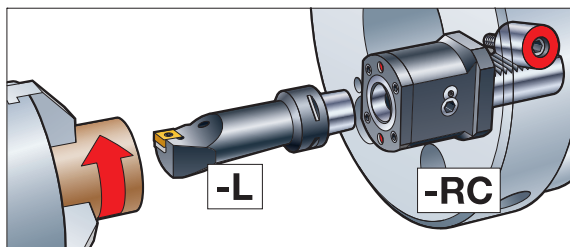

Note: Polygon sleeve must be turned 180°. See Metal cutting technical guide.

Clockwise spindle direction

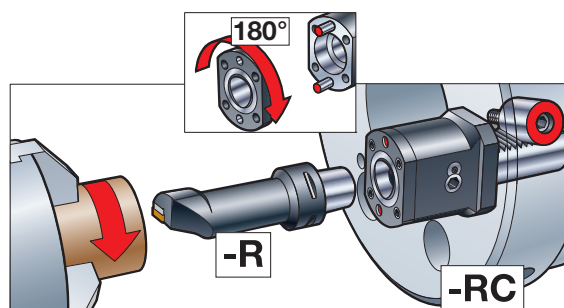

Note: Polygon sleeve must be turned 180°. See Metal cutting technical guide.

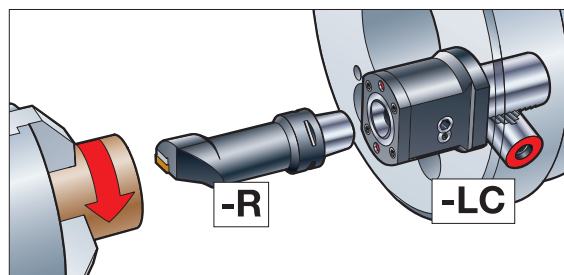

Anti-clockwise spindle direction

Manually operated clamping units

VDI angled
Camshaft activated

DIN 69880

B

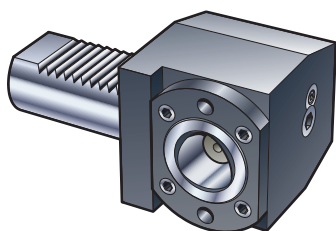

Turret type

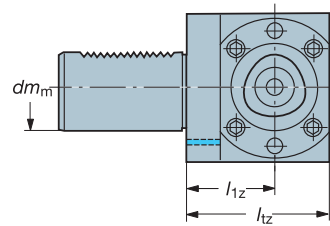
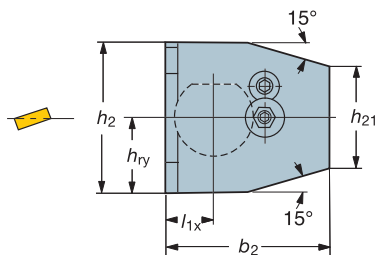
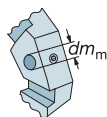

Right hand style shown.
Left hand style reflected.

Note: Maximum coolant pressure is 80 bar (PSI 1160)

C

Metric version

Turret type			Dimensions, mm						
dm_m , size, mm	Coupling size	Ordering code	b_2	h_{ry}	h_2	h_{21}	l_{1x}	l_{2z}	l_{1z}
30	C3	C3-R/LC2030-41020M	74	30	57	38	20	60	41
	C3	C3-R/LC2030-41030M	73	30	57	41	30	60	41
40	C4	C4-R/LC2040-51030M	86	38	75	54	30	75	51
	C4	C4-R/LC2040-51040M	86	38	75	60	40	75	51
	C5	C5-R/LC2040-53030M	99	41	82	47	30	85	53
50	C5	C5-R/LC2040-53040M	99	41	82	53	40	85	53
	C5	C5-R/LC2050-53030M	99	43	86	59	30	85	53
60	C5	C5-R/LC2050-53040M	99	43	86	65	40	85	53
	C6	C6-R/LC2060-43040M	99	53	94	76	40	75	43
	C6	C6-R/LC2060-53040	122	53	105	70	40	95	53

G

VDI straight

Camshaft activated

DIN 69880

H

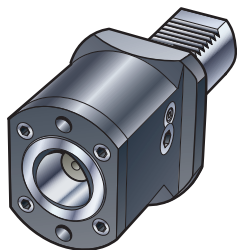

Turret type

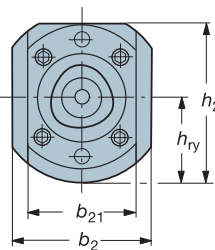
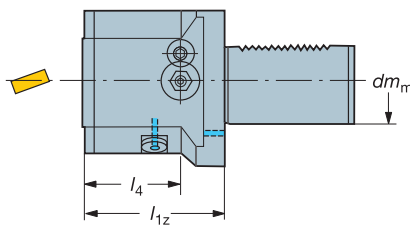
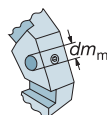

Right hand style shown.
Left hand: hexagon clamping socket on opposite side of the tool.

Note: Maximum coolant pressure is 80 bar (PSI 1160)

Metric version

Turret type			Dimensions, mm					
dm_m , size, mm	Coupling size	Ordering code	b_2	b_{21}	h_{ry}	h_2	l_{1z}	l_4
30	C3	C3-R/LC2030-00060M	50	38	34	61	60	44
40	C4	C4-R/LC2040-00075M	75	48	41	75	75	53
	C5	C5-R/LC2040-00085M	75	64	41	82	85	72
50	C4	C4-R/LC2050-00065M	70	48	49	83	65	39
	C5	C5-R/LC2050-00085M	83	64	49	91	85	62
60	C5	C5-R/LC2060-00075M	80	64	58	100	75	16
	C6	C6-R/LC2060-00095	84	84	58	111	95	50

Note! Tighten the screw with a torque wrench. Information on page G65.

J

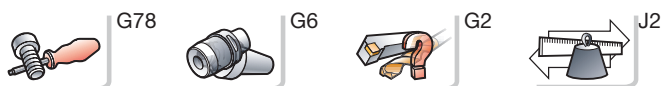

Coromant Capto® Disc Interface

High performance now as standard

The Coromant Capto Disk Interface (CDI) offers full quick-change tooling capabilities for turning centres. As a dedicated interface for driven and static turning tool holders, it enables many benefits over similar turret systems as an optimized method of fixing holders to the turret disk.

Quick-change tooling is more effective with CDI. It offers higher rigidity, faster set-ups and reduced machine downtime from secure clamping and Coromant Capto - the market-leading quick-change tooling solution.

Machining benefits

Better cutting performance

The CDI carries larger loads (compared to VDI turrets) thanks to larger Coromant Capto sizes and shorter swing diameter.

Workpiece surface improved

Increased stability reduces vibration and tool chatter to give higher component quality.

Longer tool life

Stable tooling increases tool life.

More cutting tool length

The clamping mechanism is built in to the turret, to provide more space for cutting tool length.

Shorter gauge-line swing diameter

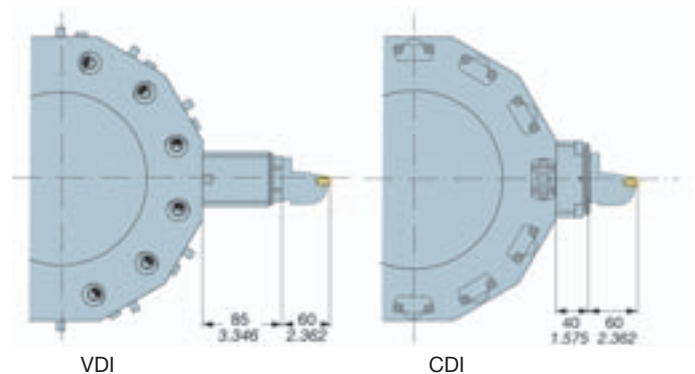

CDI is compatible mainly with European machine tools and follows the standard turret configuration of many lathe producers. CDI also fits multi-task machines having a lower turret with static and/or driven tools.

Note: For CDI version TN340 0001

Quicker tool changes

The CDI turret system is designed for Coromant Capto® quick change tooling systems.

Short tool holder projection

The design of CDI with short swing diameter provides added space for tool changing, longer tools, or bigger components.

Stable and rigid tooling

The CDI is securely bolt-on mounted to the turret to give secure positioning.

Flexible symmetric interface

Achieve more with fewer tools, as interchangeable tool holders can be mounted to face the main- or sub-spindle.

Fine adjustment possibility

All CDI tools can be fine-adjusted

A

Manually operated clamping units

CDI internal

Camshaft activated

B

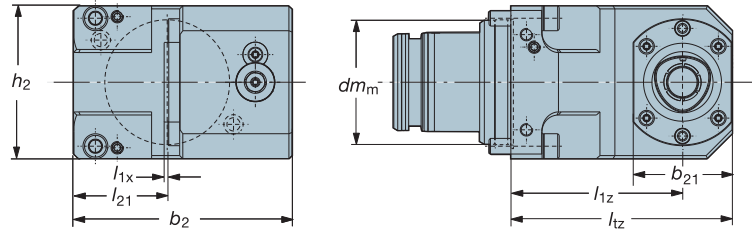

Note: Maximum coolant pressure is 80 bar (PSI 1160)

Right hand style shown.
Left hand style reflected.

C

Metric version

dm_m , size, mm	Coupling size	Ordering code	Dimensions, mm, inch							
			b_2	b_{21}	h_2	l_{1x}	l_{1z}	l_{21}	l_{2z}	$\overset{\circ}{\text{kg}}$
80	C5	C5-R/LCI80-000110	140	64	98	0	110	60	142	9.2
		C5-R/LCI80-000120	140	64	98	0	120	152	10.4	
			5.512	2.520	3.858	.000	4.331	2.362	5.591	
			5.512	2.520	3.858	.000	4.724	5.984		

Note! Tighten the screw with a torque wrench. Information on page G65.

R = Right hand, L = Left hand

G

CDI internal

Camshaft activated

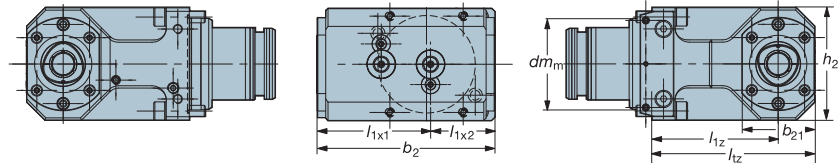

Note: Maximum coolant pressure is 80 bar (PSI 1160)

Right hand style shown.
Left hand style reflected.

H

Metric version

dm_m , size, mm	Coupling size	Ordering code	Dimensions, mm, inch							
			b_2	b_{21}	h_2	l_{1x1}	l_{1x2}	l_{1z}	l_{2z}	$\overset{\circ}{\text{kg}}$
80	C5	C5-R/LCI80-096110-2	156	64	98	96	60	110	142	13.4
			6.142	2.520	3.858	3.780	2.362	4.331	5.591	

J

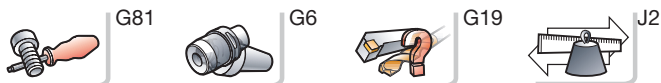

Manually operated clamping units

CDI external

Camshaft activated

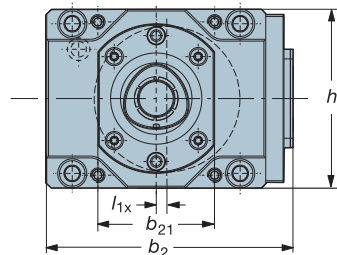
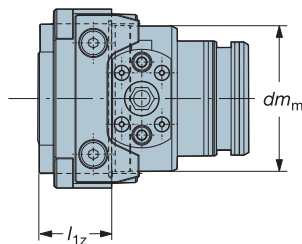
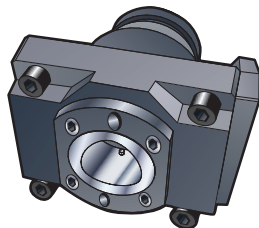

Note: Maximum coolant pressure is 80 bar (PSI 1160)

Right hand style shown.
Left hand style reflected.

Metric version

dm_m , size, mm	Coupling size	Ordering code	Dimensions, mm, inch				
			b_2	b_{21}	h_2	l_{1x}	l_{1z}
80	C5	C5-R/LCE80-040000	135	64	98	0	40
			5.315	2.520	3.858	.000	1.575

Note! Tighten the screw with a torque wrench. Information on page G65.

Machine models for CDI 80

Emco Hyperturn 690,
Gildemeister GMX 250 - 400,
J.G. Weisser Univertor,
MAG Boehringer VDF 450,
MAG Hessapp DVT 550,
Monforts RNC 700,
Scherer VDZ 320,
420; WDZ 250 Duo,
WDZ 350



G81



G6



G19



J2

Manually operated clamping units

CDI external
Camshaft activated

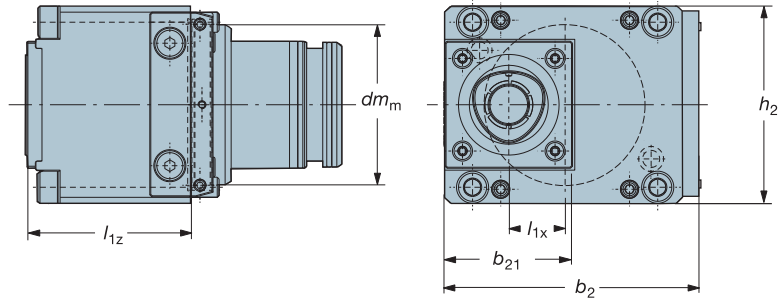
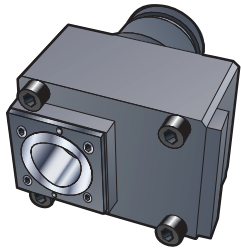

Right hand style shown.
Left hand style reflected.

Note: Maximum coolant pressure is 80 bar (PSI 1160)

Metric version

dm_m , size, mm	Coupling size	Ordering code	Dimensions, mm, inch				
			b_2	b_{21}	h_2	l_{1x1}	l_{1z}
80	C5	C5-R/LCE80-028082	130	64	98	28	82
			5.118	2.520	3.858	1.102	3.228

CDI external double

Camshaft activated

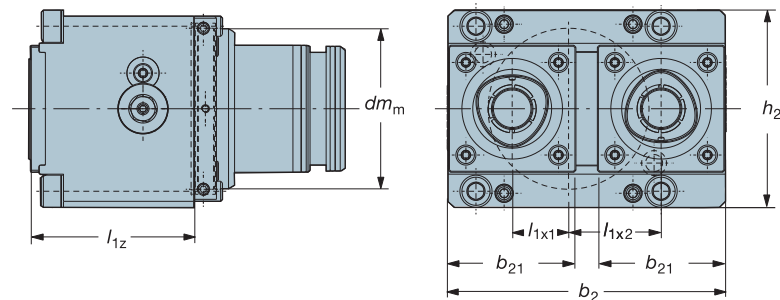
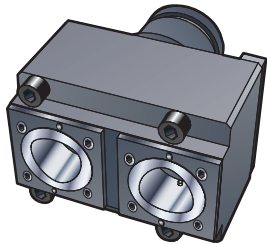

Right hand style shown.
Left hand style reflected.

Note: Maximum coolant pressure is 80 bar (PSI 1160)

Metric version

dm_m , size, mm	Coupling size	Ordering code	Dimensions, mm, inch					
			b_2	b_{21}	h_2	l_{1x1}	l_{1x2}	l_{1z}
80	C5	C5-R/LCE80-028082-2	138	64	98	28	46	82
			5.433	2.520	3.858	1.102	1.811	3.228

Note! Tighten the screw with a torque wrench. Information on page G65.



Driven tool holders

External

With internal and external coolant
Cx-DNE80-044000-I
With external coolant only
Cx-DNE80-044000-E

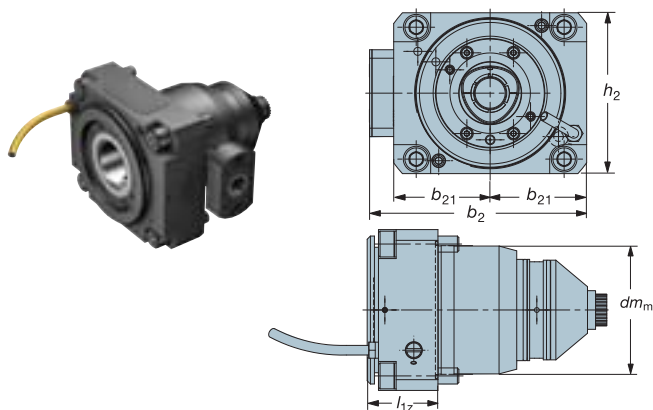

Internal

With internal and external coolant
Cx-DNI80-040110-I
With external coolant only
Cx-DNI80-040110-E

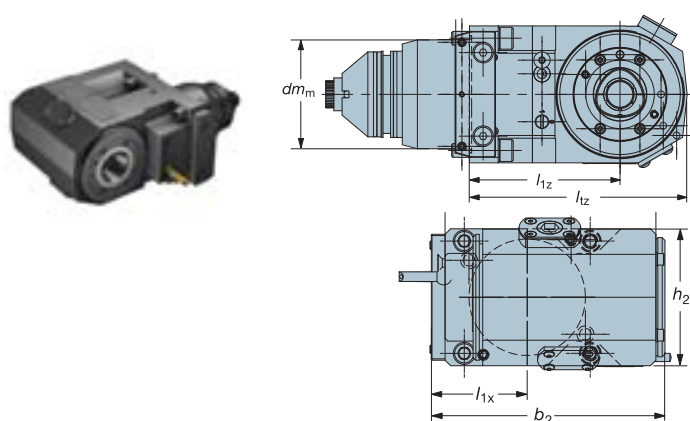

dm_m , size, mm	Coupling size	Ordering code	Dimensions, mm, inch						 kg
			b_2	b_{21}	h_2	l_{1z}	l_{1z}	l_{1x}	
80	C5	C5-DNE80-044000-E	135	60	100	40			5
			5.315	2.362	3.937	1.575			
		C5-DNI80-040110-E	170.6		100	110	159		15.78
			6.716		3.937	4.331	6.260		
80	C5	C5-DNE80-044000-I	135	60	100	40		40	5.5
			5.315	2.362	3.937	1.575		1.575	
		C5-DNI80-040110-I	175		100	110	159	40	16.3
			6.890		3.937	4.331	6.260	1.575	



G85



G7



J2

A

Adaptor for CDI

Adaptor for parting blades

APB-TNE-CDI80-25

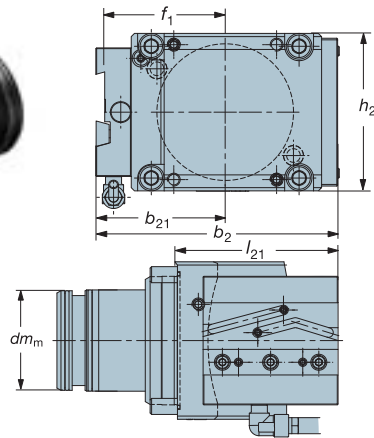

Adaptor for boring bars

ABB-TNI-CDI80-40-000120

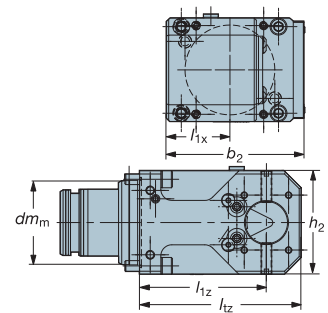

C

Adaptor for shank holder

ASH-TNE-CDI80-25

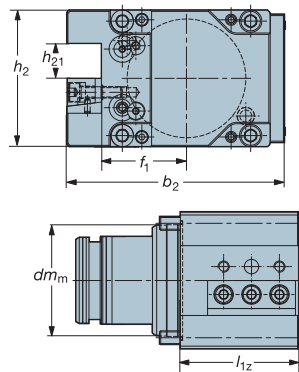

G

Right hand style shown

Metric version

dm_m , size, mm	For blade size	Ordering code	Dimensions, mm, inch					
			b_2	b_{21}	f_1	h_2	l_{21}	
80	25	APB-TNE-CDI80-25	150.5	80.5	75	98	100	5.2
			5.925	3.169	2.953	3.858	3.937	

H

dm_m , size, mm	For boring bar dia.	Ordering code	Dimensions, mm, inch				
			b_2	h_2	l_{1z}	l_{2z}	
80	40	ABB-TNI-CDI80-40-000120	130	98	120	153	10.29
			5.118	3.858	4.724	6.024	

I

dm_m , size, mm	For shank size	Ordering code	Dimensions, mm, inch				
			b_2	f_1	h_2	l_{1z}	
80	25	ASH-TNE-CDI80-25	156	61	98	85	6.51
			6.142	2.402	3.858	3.346	

J



G82



G6



J2

Quick change Dovetail for heavy duty lathes with head-type tool turrets (DIN 69881)

Tool change in a head-type tool turret is time-consuming and difficult, as tool are heavy, often 15-20 kg (33-44 lbs). A typical change of a shank tool takes 15 minutes plus a measuring cut of 2 minutes. With Coromant Capto® clamping units, you reduce tool change time to 1 minute and benefit from lighter tool holders below 5 kg (11 lbs).

Start machining right away, as measurings cut can be avoided.



Manually operated clamping units

VDI
DIN 69881

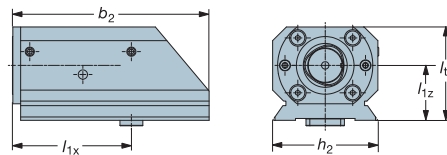

C6 - RC 140 - 165 L

Dovetail size
 l_{1x}
 Size 115 = 130 mm
 Size 140 = 165/ 205 mm

Right hand style shown

Metric version

dm_m , size, mm	Coromant Capto size	Ordering code	Dimensions, mm, inch					
			b_2	h	h_2	l_{1x}	l_{1z}	l_{2z}
115	C6	C6-R/LC115-130L	215	115	115	130	102	13.9
			8.465	4.528	4.528	5.118	4.016	
140	C6	C6-R/LC140-165L	310	140	140	165	102	22.2
			12.205	5.512	5.512	6.496	4.016	
140	C8	C8-R/LC140-165L	310	140	140	165	120	27.2
			12.205	5.512	5.512	6.496	4.724	
140	C6	C6-R/LC140-205L	350	140	140	205	102	25.5
			13.780	5.512	5.512	8.071	4.016	
140	C8	C8-R/LC140-205L	350	140	140	205	120	31.7
			13.780	5.512	5.512	8.071	4.724	

R = Right hand, L = Left hand



A

Accessories

Cover plug for clamping unit

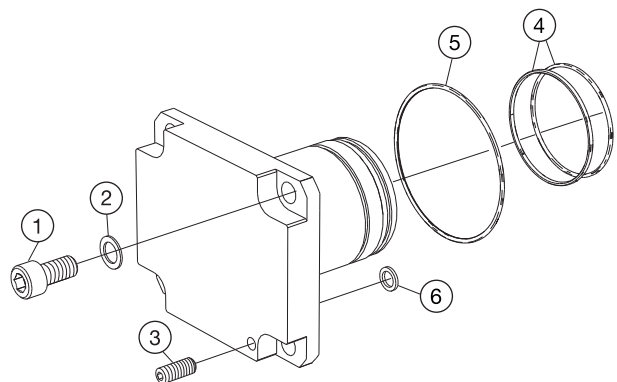
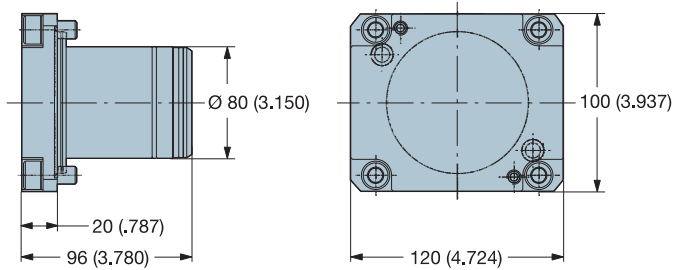

B

C

	1.	2.	3.	4.	5.	6.
Ordering code	Screw (4x)	Locking washer (4x)	Set screw (2x)	O-ring	O-ring	Kantseal (2x)
CDI80-CP-01	3212 010-460	5541 041-02	3214 010-410	5641 005-104	5641 001-79	5641 070-04

Cover plug for adaptor

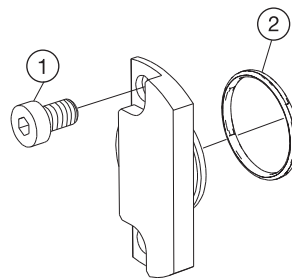
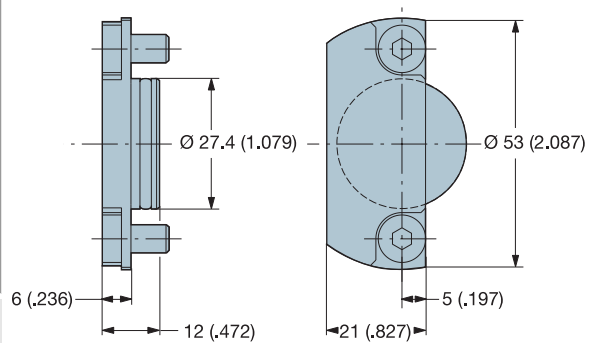

G

H

	1.	2.
Ordering code	Screw (2x)	O-ring
CDI80-CP-02	5512 060-23	5641 005-103

I

J

Automatic clamping units

On automatic clamping units, hydraulic pressure is used to activate the forward and backwards movement of the drawbar. It also gives the cutting unit a "kick" to free it from the clamping unit when it is to be changed. The clamping mechanism is mechanically self-locking i.e., the oil pressure is not applied during the cutting process. The units operate with a hydraulic pressure of 100 bar for size C4, 80 bar for sizes C5, C6, C8 and C10.

All NC 5000 clamping units uses segment clamping.

The 5000 type clamping unit is designed for special adaptation to the machine. It is used in connection with manual push-button tool changing and in fully automatic installations with magazines and tool changers.

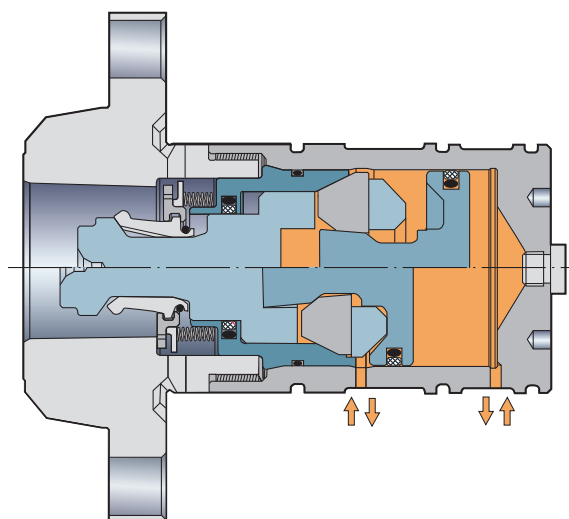

Push button valve

The push button operated valve is delivered ready to be installed in pockets at turret discs or tool blocks designed for hydraulically operated clamping units.

As the valve is produced as a cartridge in one size, it is possible to machine the pocket and simply assemble the valve and lock it with a screw.

For ordering, see spare parts and accessories.



Build-in instructions

Regarding detailed build-in instructions see the Metal cutting Technical guide, and/or contact your local Sandvik office.

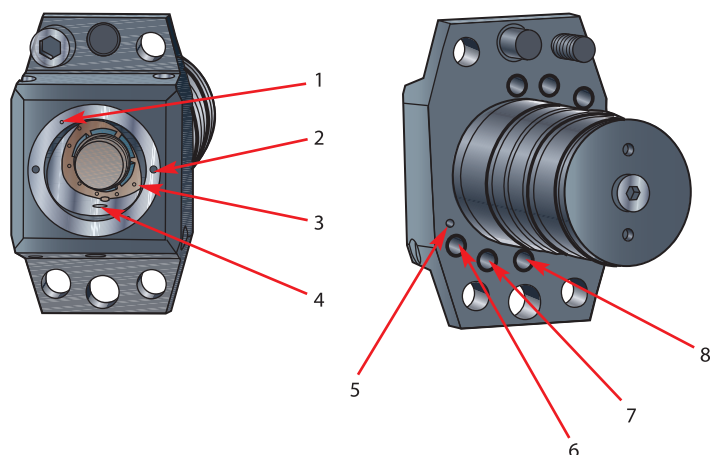

1. Tool presence air
2. Probe contact
3. Air blast
4. Coolant
5. Probe contact
6. Coolant inlet
7. Air inlet tool presence system
8. Air blast inlet

Hydraulically operated clamping units

B

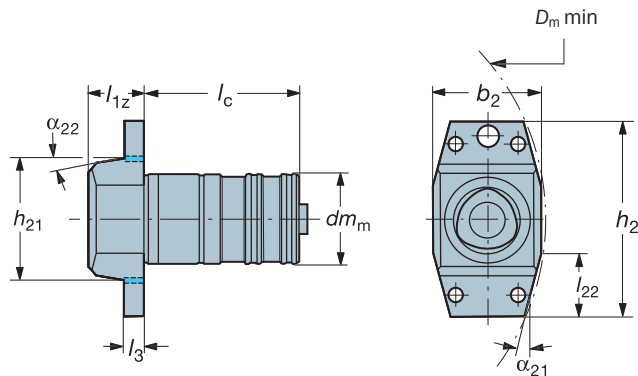
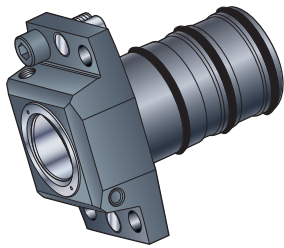

Neutral style shown.

Type NC5010 for coolant pressure up to 80 bar (1160 PSI).

Metric version

Coupling size	Ordering code	Dimensions, mm											
		b_2	dm_m	$D_m \text{ min}$	h_2	h_{21}	l_c	l_{1z}	l_3	l_{22}	α_{21}	α_{22}	
C4	C4-NC5010-00025	48	42	260	92	56	74	25	10	22	15°	11°	1.4
C5	C5-NC5010-00035	64	55	300	112	70	88	35	12	30	16°	10°	2.7
C6	C6-NC5010-00040	84	70	400	143	90	105	40	16	45	15°	10°	5.4
C8	C8-NC5010-00050	100	90	500	180	110	120	50	18	59	15°	10°	9.4
C10	C10-NC5010-00050	126	105	530	220	130	160	50	24	65	15°	15°	15.5

G

Hydraulically operated clamping units with probe contact

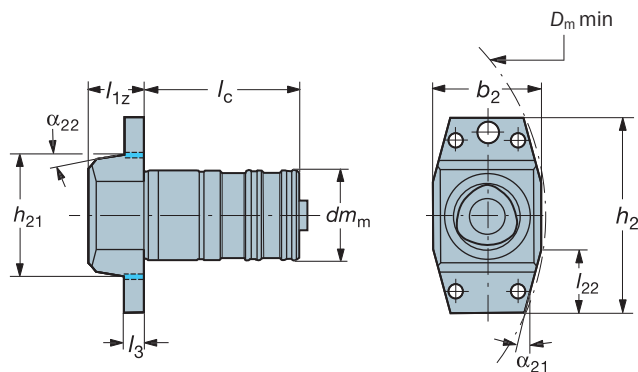
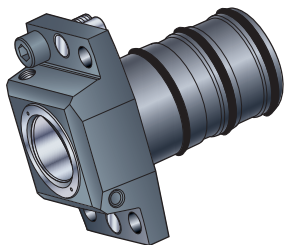

Neutral style shown.

H

Type NC5110 for coolant pressure up to 80 bar (1160 PSI), and equipped with probe contacts

Metric version

Coupling size	Ordering code	Dimensions, mm										
		b_2	dm_m	$D_m \text{ min}$	h_2	h_{21}	l_c	l_{1z}	l_3	l_{22}	α_{21}	α_{22}
C4	C4-NC5110-00025	48	42	260	92	56	74	25	10	22	15°	11°
C5	C5-NC5110-00035	64	55	300	112	70	88	35	12	30	16°	10°
C6	C6-NC5110-00040	84	70	400	143	90	105	39.5	16	45	15°	10°
C8	C8-NC5110-00050	100	90	500	180	110	120	50	18	59	15°	10°

J



G88



G6



G2

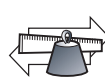

J2

Hydraulically operated clamping units with Jetbreak™

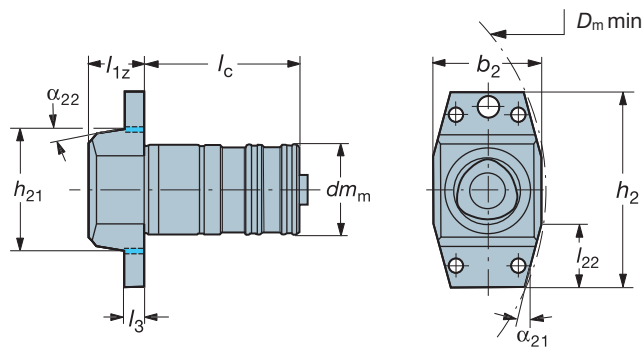
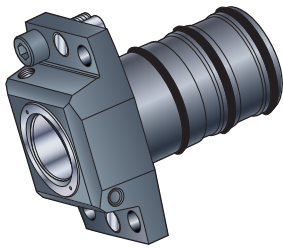

Neutral style shown.

Type NC5210 for coolant pressure over 100 bar (1450 PSI).

Metric version

Coupling size	Ordering code	Dimensions, mm										
		b_2	dm_m	$D_m \text{ min}$	h_2	h_{21}	l_c	l_{1z}	l_3	l_{22}	α_{21}	α_{22}
C6	C6-NC5210-00040	84	70	400	143	90	105	40	16	45	15°	10°
C8	C8-NC5210-00050	100	90	500	180	110	120	50	18	59	15°	10°

Coromant Capto® required pressure:

Hydro-mechanical clamping units type 5000

Coupling size	Clamping pressure	
	Bar	PSI
C4	100	1450
C5	80	1160
C6	80	1160
C8	80	1160
C10	80	1160

Required oil flow in all cases: 6 l/min (1.6 gal/min)



G89



G6



G2



J2

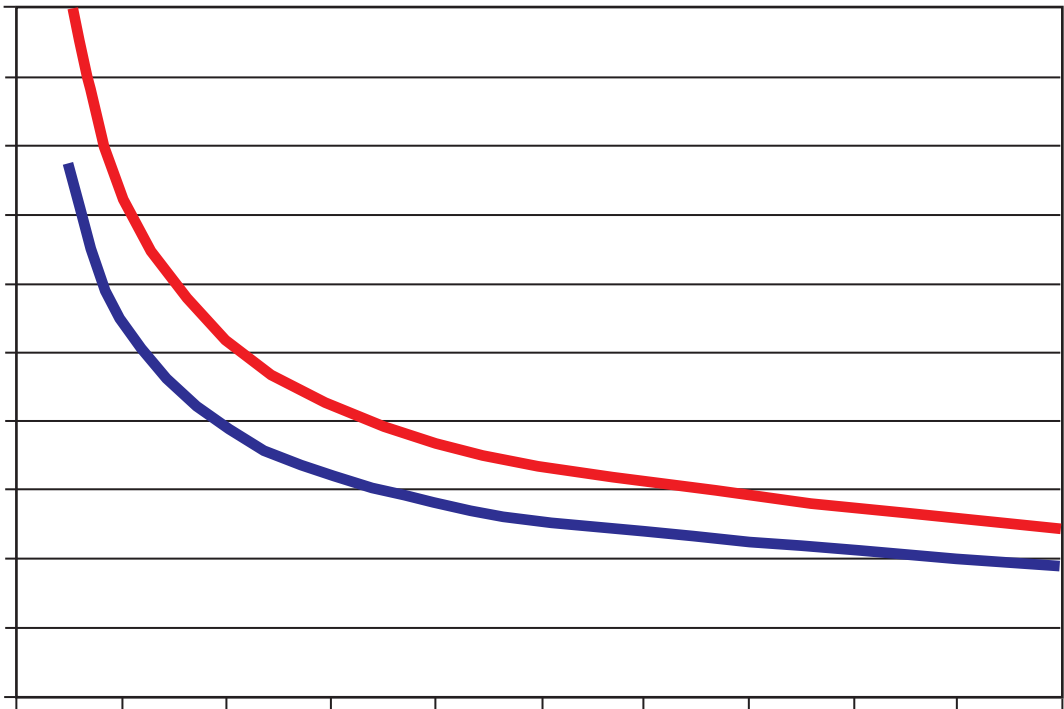

Machine adapted clamping units

These clamping units and driven tool holders are designed to fit specific turret interfaces.

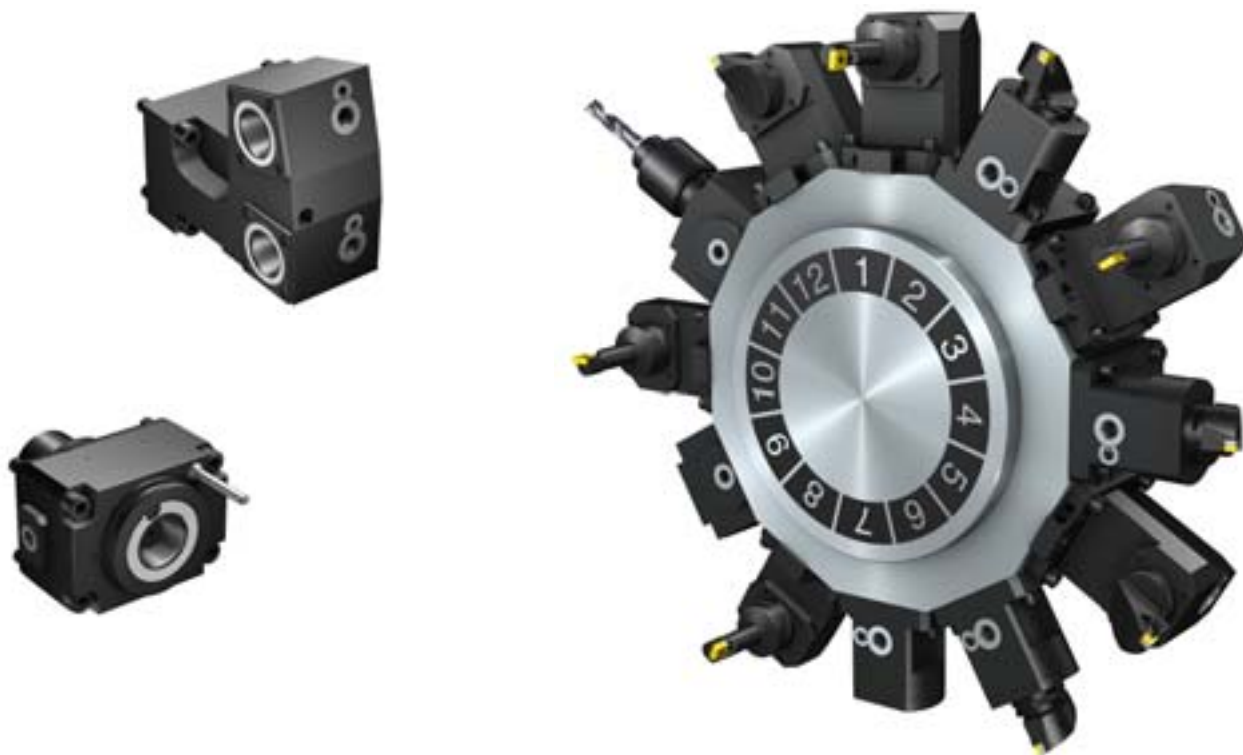

CBI

Coromant Capto Bolt on Interface - unique hole pattern for each machine brand.

Quick Change Coromant Capto® clamping units provide unrivalled performance, ensuring that machine utilization is optimized through reduced setup and production time.

For machine type:

Mazak, see page G38

Mori Seiki, see page G42

Doosan, see page G46

Nakamura Tome, see page G49

Okuma, see page G51

A

How to choose clamping unit

Internal setup

B

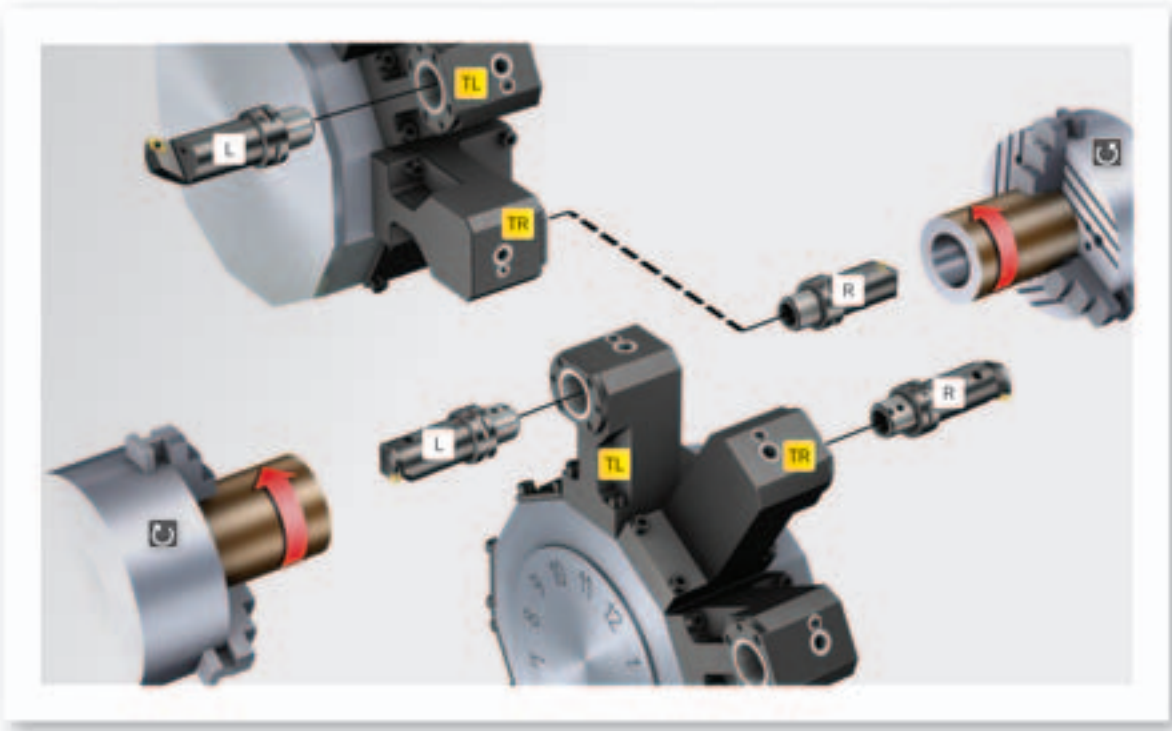

C

G

H

I

J

External setup



Internal setup

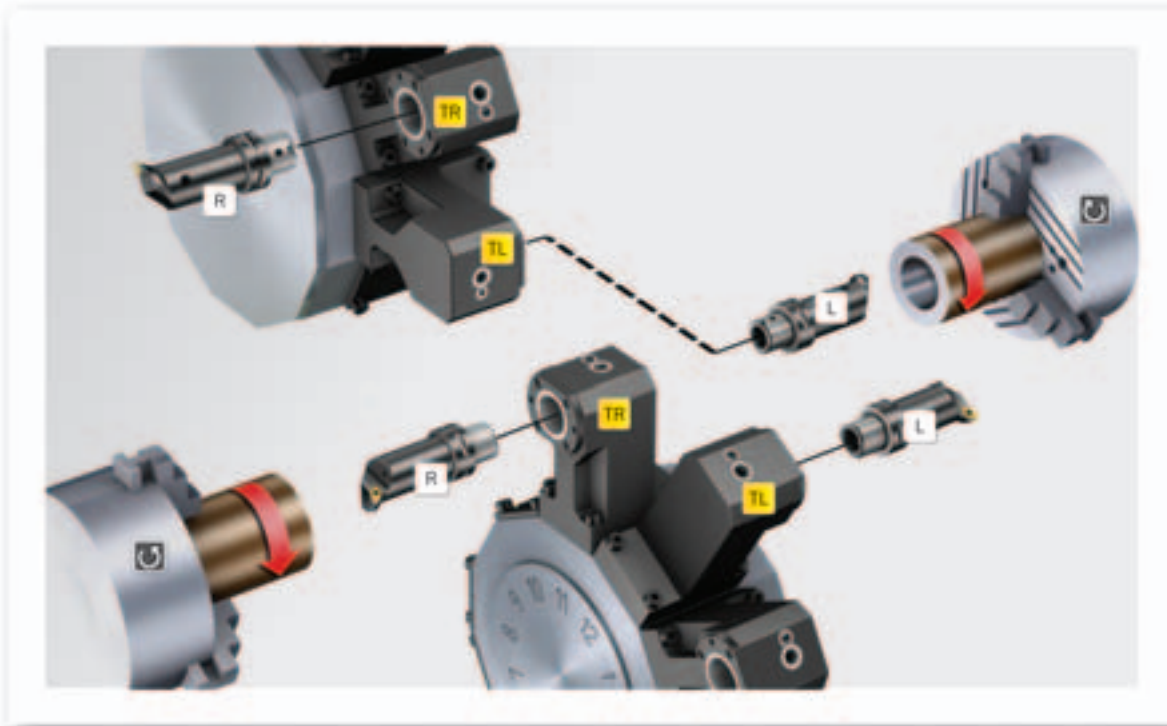

External setup

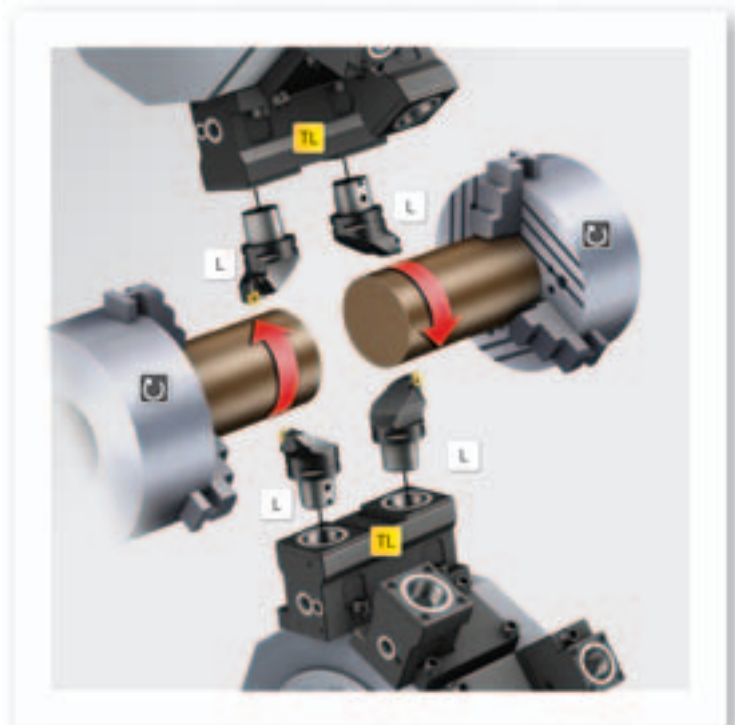

- R Right hand cutting unit
- L Left hand cutting unit
- TR Right hand clamping unit
- TL Left hand clamping unit
- Clockwise spindle rotation
- Anticlockwise spindle rotation

Code key for Machine adapted clamping units (MACU)

C5	-	D	N	I	-	MZ	68	A	-	DT	I
1		2	3	4		5	6	7		8	9

1 Coromant Capto® size

C4-40mm,
C5-50mm

6 Turret hole dia (mm)

40, 50, 55, 60, 65, 68, 75, 85, 110

2 Application

T-Turning
D-Driven

7 Turret interface version

A, B, C
V = VDI style

3 Hand of clamping units

L - Left
R - Right
N - Neutral

8 Configuration

For normal single clamping units, no coding

DT = for main spindle and subspindle (two clamping units in one holder)

ET = extended

DE = extended for main spindle and subspindle (two clamping units in one holder)

TT = for machine with half index turret (two clamping units in one holder)

YT = for machines with "Y" axis (two clamping units in one holder)

DY = for machines with "Y" axis (four clamping units in one holder)

SS = for subspindle

SP = short projection

XT = two clamping units in one holder (change tools with X axis)

4 Type of operation

E - External (OD)
I - Internal (face/ID)

5 Machine

MZ - Mazak
MS - Mori Seiki
NA - Nakamura
OK - Okuma
BT - Bolt on turret (Doosan)

9 Coolant supply (driven tools only)

I - Internal and external (80bars)
E - External only

Machine adapted clamping units

CBI

Turning

External

For machining with half index turret
Cx-TR/LE-xxxx-TT

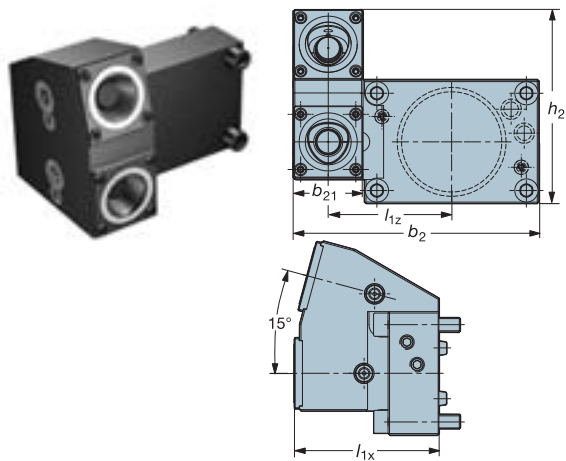

For main spindle and sub spindle
Cx-TR/LE-xxxx-DT

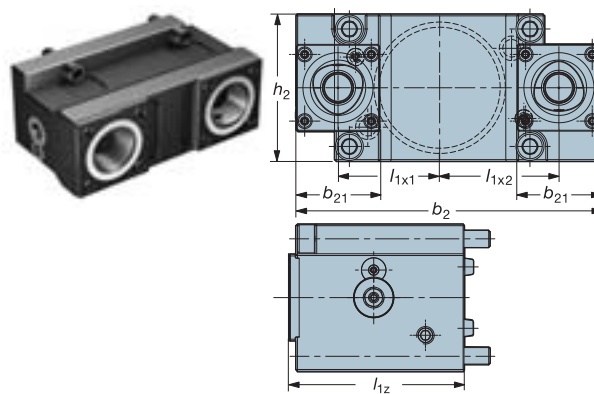

Normal single clamping unit
Cx-TR/LE-xxxx

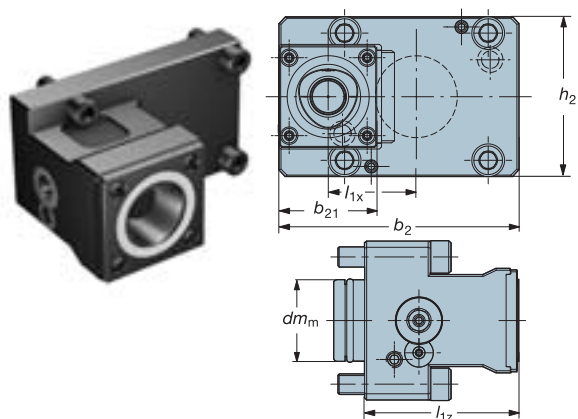

For machining with "Y" axis
Cx-TR/LE-xxxx-YT

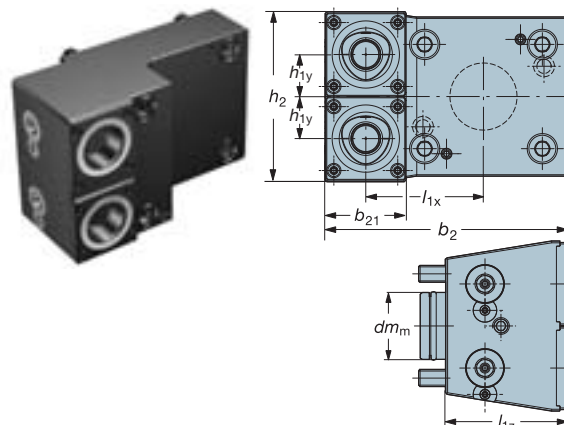

Right hand style shown

A

Machine adapted clamping units

CBI

Turning

Internal

B

Normal single clamping unit, right hand
Cx-TR/LI-xxxxx

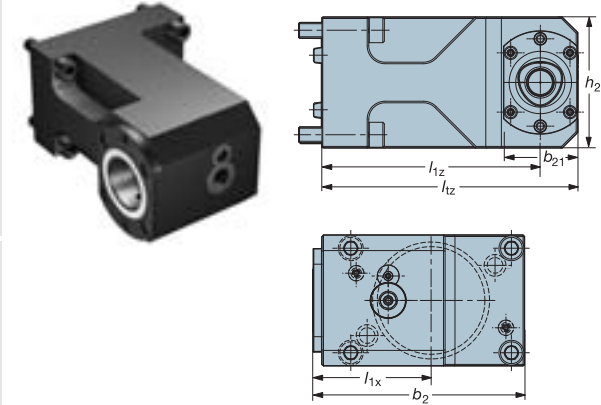

For sub spindle
Cx-TR/LI-xxxxx-SS

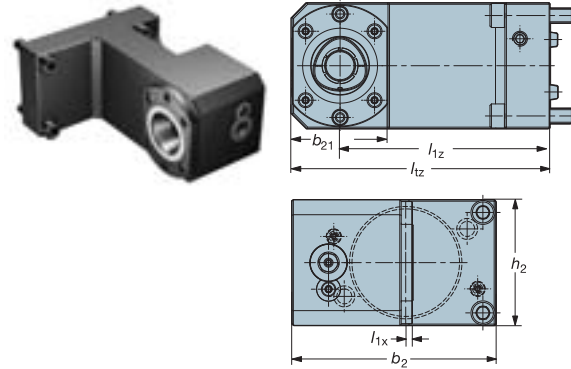

C

Change tools with "X" axis
Cx-TR/LI-xxxxx-XT

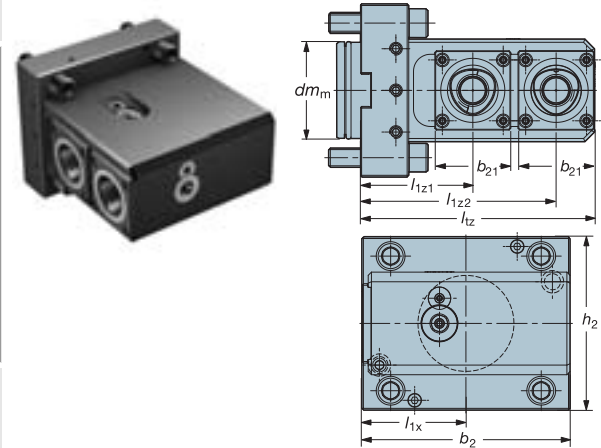

For machining with "Y" axis
Cx-TR/LI-xxxxx-YT

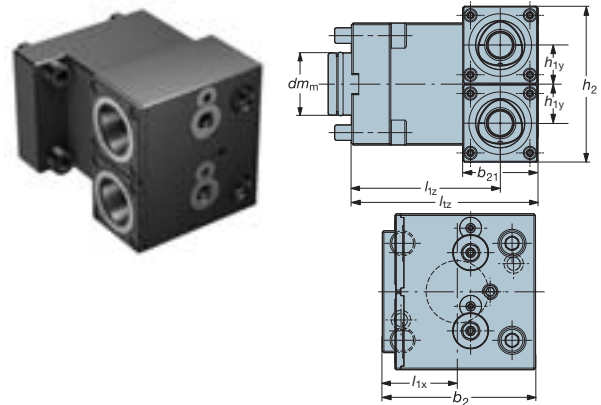

G

H

For main spindle and sub spindle
Cx-TR/LI-xxxxx-DT

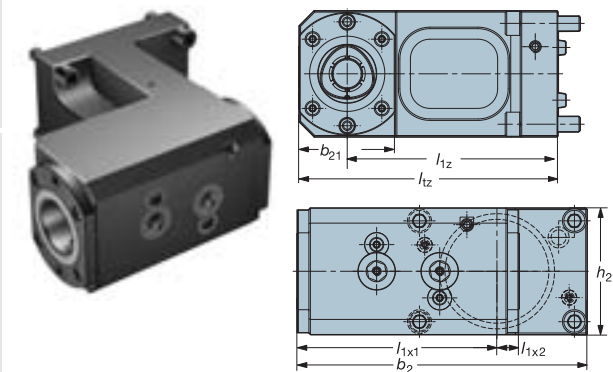

For machining with half index turret
Cx-TR/LI-xxxxx-TT

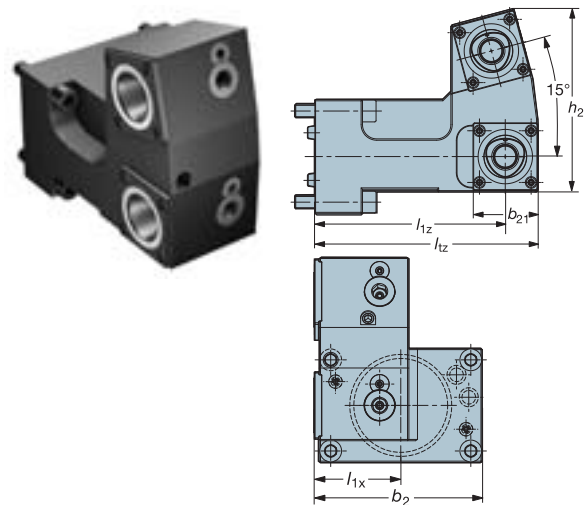

I

J

Right hand style shown

Driven tool holders

CBI

External

With internal and external coolant

Cx-DNE-xxxxx-I

With external coolant only

Cx-DNE-xxxxx-E

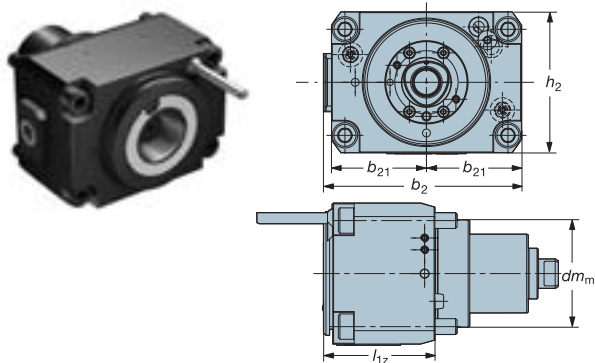

Right hand style shown

Internal

With internal and external coolant

Cx-DNI-xxxxx-I

With external coolant only

Cx-DNI-xxxxx-E

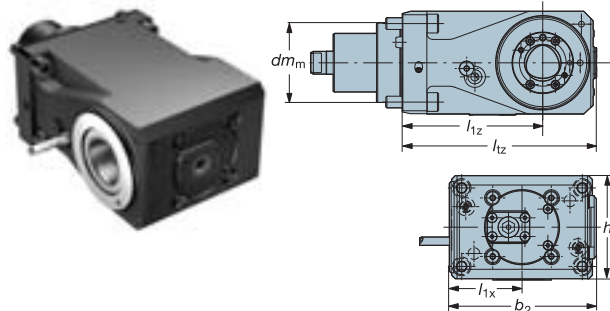

Adaptor for parting blades

APB-TNE-xxxxx-25

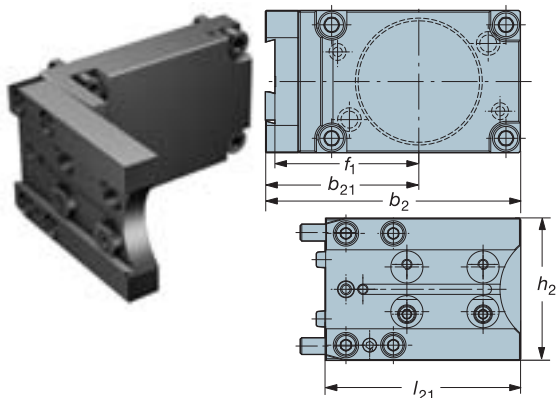

Machine adapted clamping units

CBI

Mazak

MZ68A

Quick Turn Nexus 200 - 250

Only for the optional CBI 68A turret

B

Metric version

dm_m , size, mm	Coupling size	Ordering code	Dimensions, mm, inch					
			b_2	b_{21}	h_2	l_{1z}	l_{2z}	
68	C4	C4-TR/LE-MZ68A	142	48	84	100		4.6
			5.591	1.890	3.307	3.937		
		C4-TR/LE-MZ68A-DT	174	48	84	100		7.6
			6.850	1.890	3.307	3.937		
		C4-TR/LE-MZ68A-TT	169	48	133.6	100		6.1
			6.654	1.890	5.260	3.937		
68	C5	C5-TR/LE-MZ68A	142	64	84	90		3.4
			5.591	2.520	3.307	3.543		
		C5-TR/LE-MZ68A-DT	174	64	84	90		6.7
			6.850	2.520	3.307	3.543		
68	C4	C4-TR/LI-MZ68A	136	48	84	140	164	8.3
			5.354	1.890	3.307	5.512	6.457	
		C4-TR/LI-MZ68A-DT	163	48	84	140	164	8.5
			6.417	1.890	3.307	5.512	6.457	
		C4-TR/LI-MZ68A-SS	136	48	84	140	164	8
			5.354	1.890	3.307	5.512	6.457	
68	C5	C4-TR/LI-MZ68A-TT	124	48	151		164	8.3
			4.882	1.890	5.945		6.457	
		C5-TR/LI-MZ68A	135	64	84	140	172	8.3
			5.315	2.520	3.307	5.512	6.772	
68	C5	C5-TR/LI-MZ68A-DT	193	64	84	140	172	9.8
			7.598	2.520	3.307	5.512	6.772	
		C5-TR/LI-MZ68A-SS	136	64	84	140	172	8.4
			5.354	2.520	3.307	5.512	6.772	

R = Right hand, L = Left hand

Driven tool holders

dm_m , size, mm	Coupling size	Ordering code	Dimensions, mm, inch						
			b_2	b_{21}	h_2	l_{1x}	l_{1z}	l_{21}	
68	C4	C4-DNE-MZ68A-E	125	60	89		70.5		5.7
			4.921	2.362	3.504		2.776		
68	C5	C5-DNE-MZ68A-E	125	60	89		75		5.7
			4.921	2.362	3.504		2.953		
68	C4	C4-DNE-MZ68A-I	125	60	89		70.5		6
			4.921	2.362	3.504		2.776		
68	C5	C5-DNE-MZ68A-I	125	60	89		75		6
			4.921	2.362	3.504		2.953		
68	C4	C4-DNI-MZ68A-E	125.6		88	60	120	163	11.2
			4.945		3.465	2.362	4.724	6.417	
68	C5	C5-DNI-MZ68A-E	125.6		88	60	120	163	11.1
			4.945		3.465	2.362	4.724	6.417	
68	C4	C4-DNI-MZ68A-I	130		88	60	120	163	11.3
			5.118		3.465	2.362	4.724	6.417	
68	C5	C5-DNI-MZ68A-I	130		88	60	120	163	11.3
			5.118		3.465	2.362	4.724	6.417	

N = Neutral

Adaptor for parting blades

dm_m , size, mm	For blade size	Ordering code	Dimensions, mm, inch					
			b_2	b_{21}	f_1	h_2	l_{21}	
68	25	APB-TNE-MZ68A-25	150.5	90.5	85	84	115	3.6
			5.925	3.563	3.346	3.307	4.528	

N = Neutral

Spare parts for machine adapted clamping units can be downloaded

www.sandvik.coromant.com

Online catalogues

Download catalogues

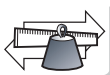

J

Machine adapted clamping units

CBI

Mazak

MZ68B

For Quick Turn Smart 200 machines QTS200M

Metric version

<i>dm_m</i> , size, mm	Coupling size	Ordering code	Dimensions, mm, inch				
			<i>b</i> ₂	<i>h</i> ₂	<i>l</i> _{1x}	<i>l</i> _{1z}	
68	C4	C4-TR/LE-MZ68B	153	85	52	55	4.5
			6.024	3.346	2.047	2.165	
68	C4	C4-TR/LI-MZ68B	152	85	75	95	7.5
			5.984	3.346	2.953	3.740	

R = Right hand, L = Left hand

Driven tool holders

<i>dm_m</i> , size, mm	Coupling size	Ordering code	Dimensions, mm, inch				
			<i>b</i> ₂	<i>h</i> ₂	<i>l</i> _{1x}	<i>l</i> _{1z}	
68	C4	C4-DNE-MZ68B-E	127	84		55	4
			5.000	3.307		2.165	
			C4-DNE-MZ68B-I	127	84		55
5.000	3.307			2.165			
68	C4	C4-DNI-MZ68B-E	144	84	65	80	7.9
			5.669	3.307	2.559	3.150	
			C4-DNI-MZ68B-I	144	84	65	80
5.669	3.307	2.559		3.150			

N = Neutral

Machine models:

Quick Turn Smart 200M



Spare parts for machine adapted clamping units can be downloaded

www.sandvik.coromant.com

Online catalogues

Download catalogues

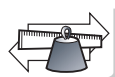

Manually operated clamping units

VDI external

Machine adapted

MAZAK MZ50V

B

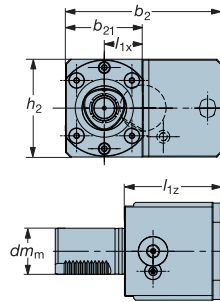

C

Note: Maximum coolant pressure is 80 bar (PSI 1160)

Right hand style shown.
Left hand style reflected.

Metric version

dm_m , size, mm	Coupling size	Ordering code	Dimensions, mm, inch					
			b_2	b_{21}	h_2	l_{1x}	l_{1z}	
50	C6	C6-TR/LE-MZ50V	169	83.5	106	42	105	10.2
			6.654	3.287	4.173	1.654	4.134	

R = Right hand, L = Left hand

G

VDI internal

Machine adapted

MAZAK MZ50V

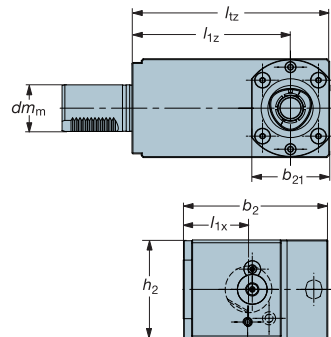

H

Note: Maximum coolant pressure is 80 bar (PSI 1160)

Right hand style shown.
Left hand style reflected.

Metric version

dm_m , size, mm	Coupling size	Ordering code	Dimensions, mm, inch						
			b_2	b_{21}	h_2	l_{1x}	l_{1z}	l_{12}	
50	C6	C6-TR/LI-MZ50V	155	83.5	106	70	170	212	17.9
			6.102	3.287	4.173	2.756	6.693	8.346	

R = Right hand, L = Left hand

Note! Tighten the screw with a torque wrench. For information, see Turning tools catalogue.

J



Spare parts for machine adapted clamping units can be downloaded

www.sandvik.coromant.com

Online catalogues

Download catalogues

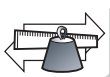

Driven tool holders

Machine adapted

MAZAK MZ50V

External

With internal and external coolant

C5-DNE-MZ50V-I

With external coolant only

C5-DNE-MZ50V-E

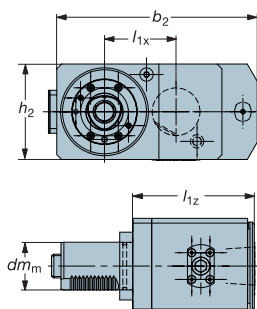

Internal

With internal and external coolant

C5-DNI-MZ50V-I

With external coolant only

C5-DNI-MZ50V-E

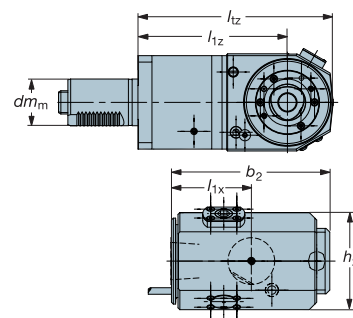

dm_m , size, mm	Coupling size	Ordering code	Dimensions, mm, inch					
			b_2	h_2	l_{1x}	l_{1z}	l_{2z}	$\frac{kg}{lb}$
50	C5	C5-DNE-MZ50V-E	210	100	75	128		13
			8.268	3.937	2.953	5.039		
50	C5	C5-DNE-MZ50V-I	210	100	75	128		13.5
			8.268	3.937	2.953	5.039		
50	C5	C5-DNI-MZ50V-E	165	104	86	160	209	16.7
			6.496	4.094	3.386	6.299	8.228	
50	C5	C5-DNI-MZ50V-I	170	104	86	160	209	17.5
			6.693	4.094	3.386	6.299	8.228	

N = Neutral

Machine models for MZ50V:

QUICK TURN NEXUS, 300, 350, 400, 450, M, MY

HYPER QUADREX 450M

SLANT TURN NEXUS 500, 550M

MEGA TURN NEXUS 900M



Spare parts for machine adapted clamping units can be downloaded

www.sandvik.coromant.com

Online catalogues

Download catalogues

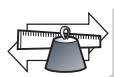

Which CBI toolholder fits to which Mori Seiki machine for MS 40A, MS 60A, MS 75A and MS 110A

CBI	MS40A turret interface				
	Machine model				
Article code	DuraTurn 2050, 2550 MC	NL 1500, 2000 (20 stn.)	NT 1000, NTX 1000, 2000	NT 3100, 3150, 3200	NZ, NZX 1500, 2000
C4-TR/LE-MS40A	x	x	x	x	x
C4-TR/LE-MS40A-DT		x	x	x	x
C4-TR/LE-MS40A-YT		x			x
C4-TR/LI-MS40A	x	x	x	x	x
C4-TR/LI-MS40A-SS			x		
C4-TR/LI-MS40A-YT		x			x
C3-DNE-MS40A-I	x	x	x	x	x
C4-DNE-MS40A-E	x	x	x	x	x
C4-DNI-MS40A-E	x	x	x	x	x
C4-DNI-MS40A-I	x	x	x	x	x
APB-TNE-MS40A-25	x	x	x	x	x
C4-TR/LI-MS40A-DT		x		x	x

CBI	MS60A turret interface			
	Machine model			
Article code	NL, NLX 1500-3000 (10/12 stn.) (MC/ Y/ SMC/ CY)	NT 4200, 4250 (12 stn.)	NT 4300, 5400 (10 stn.)	NZL 2500
C4-TR/LE-MS60A	x	x	x	x
C5-TR/LE-MS60A	x	x	x	x
C4-TR/LE-MS60A-DT	x	x	x	
C5-TR/LE-MS60A-DT	x	x	x	
C4-TR/LE-MS60A-YT	x			x
C4-TR/LI-MS60A	x			x
C5-TR/LI-MS60A	x			x
C4-TR/LI-MS60A-SS	x			x
C5-TR/LI-MS60A-SS	x			x
C4-TR/LI-MS60A-XT	x			x
C4-DNE-MS60A-E	x	x	x	x
C4-DNE-MS60A-I	x	x	x	x
C5-DNE-MS60A-E	x	x	x	x
C4-DNI-MS60A-E	x	x	x	x
C4-DNI-MS60A-I	x	x	x	x
C5-DNI-MS60A-E	x	x	x	x
C5-DNI-MS60A-I	x	x	x	x
APB-TNE-MS60A-25	x	x	x	x
C5-TR/LI-MS60A-DT	x			x

CBI	MS75A turret interface			
	Machine model			
Article code	NZX 4000			
C6-TR/LE-MS75A	x			
C6-TR/LI-MS75A	x			
C5-DNE-MS75A-E	x			
C5-DNE-MS75A-I	x			
C5-DNI-MS75A-E	x			

CBI	MS110A turret interface			
	Machine model			
Article code	NZX 6000			
C6-TR/LE-MS110A	x			
C6-TR/LI-MS110A	x			
C6-DNE-MS110A-E	x			
C6-DNE-MS110A-I	x			
C6-DNI-MS110A-E	x			
C6-DNI-MS110A-I	x			

Machine adapted clamping units

CBI

Mori Seiki 40

Metric version

dm_m , size, mm	Coupling size	Ordering code	Dimensions, mm, inch										
			b_2	b_{21}	h_2	l_{1x}	l_{1x1}	l_{1x2}	l_{1z}	l_{21}	l_z	h_{1y}	
40	C4	C4-TR/LE-MS40A	117	48	77.4	43			75				3
		C4-TR/LE-MS40A-DT	4.606	1.890	3.047	1.693			2.953				4.3
		C4-TR/LE-MS40A-YT	134	48	84		43	43	75				4.8
			5.276	1.890	3.307		1.693	1.693	2.953				25
40	C4	C4-TR/LI-MS40A	144	24	101	70			72				4.8
			5.669	.945	3.976	2.756			2.835				.984
		C4-TR/LI-MS40A-DT	100	49	77.4	32			100		124		5.8
			3.937	1.929	3.047	1.260			3.937		4.882		9
		C4-TR/LI-MS40A-SS	136		78	68			100		124		9
	5.354		3.071	2.677			3.937		4.882		5.6		
	C4-TR/LI-MS40A-SS	124		77.4	15			100	48	124		5.6	
		4.882		3.047	.591			3.937	1.890	4.882		6.5	
	C4-TR/LI-MS40A-YT	98	48	99.6	48			95		119	25	6.5	
		3.858	1.890	3.921	1.890			3.740		4.685	.984		

R = Right hand, L = Left hand

Driven tool holders

dm_m , size, mm	Coupling size	Ordering code	Dimensions, mm, inch						
			b_2	b_{21}	h_2	l_{1x}	l_{1z}	l_{21}	
40	C4	C4-DNE-MS40A-E	96	48	86.5		58		3
			3.780	1.890	3.406		2.284		
		C3-DNE-MS40A-I	96	48	80.5		59		3.5
40	C3	C4-DNI-MS40A-E	130.4		80	65	85	122	6.5
			5.134		3.150	2.559	3.346	4.803	
		C4-DNI-MS40A-I	134.8		80	65	85	122	6.7
		5.307		3.150	2.559	3.346	4.803		

N = Neutral

Adaptor for parting blades

dm_m , size, mm	For blade size	Ordering code	Dimensions, mm, inch					
			b_2	b_{21}	b_{22}	f_1	l_{21}	
40	25	APB-TNE-MS40A-25	137	87	50	81.5	90	3.2
			5.394	3.425	1.968	3.209	3.543	

N = Neutral



Spare parts for machine adapted clamping units can be downloaded

www.sandvik.coromant.com

Online catalogues

Download catalogues



Machine adapted clamping units

CBI

Mori Seiki 60

Metric version

dm _m , size, mm	Coupling size	Ordering code	Dimensions, mm, inch											
			b ₂	b ₂₁	h ₂	l _{1x}	l _{1x1}	l _{1x2}	l _{1z}	l ₂₁	l _{2z}	h _{1y}		
60	C4	C4-TR/LE-MS60A	130	48	108	41					80			6.2
		C4-TR/LE-MS60A-DT	163.5	48	4.252	1.614					3.150			7.7
		C4-TR/LE-MS60A-YT	171	48	108	82					80	29		7.48
60	C5	C5-TR/LE-MS60A	130	64	108	33					95			6.69
		C5-TR/LE-MS60A-DT	163.5	64	108						3.740			8.58
		C5-TR/LE-MS60A-YT	171	64	108	37					95	1.142		7.48
60	C4	C4-TR/LI-MS60A	130		108	65					90	114		7.8
		C4-TR/LI-MS60A-SS	130		108	65					90	114		7.5
		C4-TR/LI-MS60A-XT	130	48	108	65					90	114		7.5
60	C5	C5-TR/LI-MS60A	130	64	108	65					90	122		8.85
		C5-TR/LI-MS60A-SS	130	64	108	65					90	122		8.85
		C5-TR/LI-MS60A-DT	158	64	108		93	65	90		122			9.9
			6.220	2.520	4.252		3.661	2.559	3.543		4.803			

R = Right hand, L = Left hand

Driven tool holders

dm _m , size, mm	Coupling size	Ordering code	Dimensions, mm, inch							
			b ₂	b ₂₁	h ₂	l _{1x}	l _{1z}	l ₂₁		
60	C4	C4-DNE-MS60A-E	130	65	108		65			6.5
		C4-DNE-MS60A-I	130	65	108		65			6.5
60	C5	C5-DNE-MS60A-E	130	65	108		69.5			6.5
		C5-DNE-MS60A-I	130	65	108		69.5			6.5
60	C4	C4-DNE-MS60A-E	130	65	108		92			9.2
		C4-DNE-MS60A-I	130	65	108		92			9.2
60	C4	C4-DNI-MS60A-E	130		108	60	90	135	13	
		C4-DNI-MS60A-I	130		108	60	90	135	12	
60	C5	C5-DNI-MS60A-E	130		108	60	90	135	12	
		C5-DNI-MS60A-I	130		108	60	90	135	12	
60	C4	C4-DNI-MS60A-E	133		108	60	90	135	12	
		C4-DNI-MS60A-I	133		108	60	90	135	12	
60	C5	C5-DNI-MS60A-E	133		108	60	90	135	12	
		C5-DNI-MS60A-I	133		108	60	90	135	12	
			5.236		4.252	2.362	3.543	5.315		

N = Neutral

Adaptor for parting blades

dm _m , size, mm	For blade size	Ordering code	Dimensions, mm, inch						
			b ₂	b ₂₁	b ₂₂	f ₁	h ₂	l ₂₁	
60	25	APB-TNE-MS60A-25	147		65	76.5	108	100	4.85
		APB-TNE-MS60A-25	147		65	76.5	108	100	4.85
			5.787		2.559	3.012	4.252	3.937	

N = Neutral

Spare parts for machine adapted clamping units can be downloaded

www.sandvik.coromant.com

Online catalogues

Download catalogues

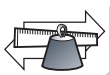

Machine adapted clamping units

CBI

Mori Seiki 75A

Metric version

dm_m , size, mm	Coupling size	Ordering code	Dimensions, mm, inch						
			b_2	b_{21}	h_2	l_{1x}	l_{1z}	l_{1z}	
75	C6	C6-TR/LE-MS75A	245		136	118	25		14
			9.646		5.354	4.646	.984		
75	C6	C6-TR/LI-MS75A	225	83.5	136	140	80	122	20.2
			8.858	3.287	5.354	5.512	3.150	4.803	

R = Right hand, L = Left hand

Driven tool holders

dm_m , size, mm	Coupling size	Ordering code	Dimensions, mm, inch					
			b_2	h_2	l_{1x}	l_{1z}	l_{1z}	
75	C5	C5-DNE-MS75A-E	155	138		70		10.2
			6.102	5.433		2.756		
			155	138		70		10.5
75	C5	C5-DNI-MS75A-E	6.102	5.433		2.756		
			205	136	105	105	161	26.2
			8.071	5.354	4.134	4.134	6.339	
		C5-DNI-MS75A-I	209	136	105	105	161	27
			8.228	5.354	4.134	4.134	6.339	

N = Neutral

Machine adapted clamping units

Mori Seiki 110A

Metric version

dm_m , size, mm	Coupling size	Ordering code	Dimensions, mm, inch					
			b_2	h_2	l_{1x}	l_{1z}	l_{1z}	
110	C6	C6-TR/LE-MS110A	299	158	43	35		18.7
			11.772	6.220	1.693	1.378		
110	C6	C6-TR/LI-MS110A	248			100	142	19.3
			9.764			3.937	5.591	

R = Right hand, L = Left hand

Driven tool holders

dm_m , size, mm	Coupling size	Ordering code	Dimensions, mm, inch					
			b_2	h_2	l_{1x}	l_{1z}	l_{1z}	
110	C6	C6-DNE-MS110A-E	220	158		85		19.7
			8.661	6.220		3.346		
			220	158		85		20.9
110	C6	C6-DNI-MS110A-E	8.661	6.220		3.346		
			220	158	105	100	160	34.7
			8.661	6.220	4.134	3.937	6.299	
		C6-DNI-MS110A-I	220	158	105	100	160	35.2
			8.661	6.220	4.134	3.937	6.299	

N = Neutral



Spare parts for machine adapted clamping units can be downloaded

www.sandvik.coromant.com

Online catalogues

Download catalogues

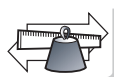

A

Which CBI toolholder fits to which Doosan machine for BMT65A, BMT75A and BMT85A

B

CBI	Doosan BMT65				
	Doosan Puma 2100, 2600, 3100 M/MS/Y/SY 12ST BMT65	Doosan Puma 2100, 2600 M/MS/Y/SY 24ST BMT65	Doosan Puma TT2000, 2500 MS/SY	Doosan Puma MX2000, 2500, 2600 T/ST/SY	Doosan Puma 300 M/MS
Article code					
C4-TR/LE-BT65A	x	x			x
C4-TR/LE-BT65A-DT	x	x	x	x	x
C4-TR/LE-BT65A-TT		x			
C4-TR/LE-BT65A-YT	x	x	x		
C4-TR/LI-BT65A	x	x			
C4-TR/LI-BT65A-SS	x	x			
C4-DNE-BT65A-E	x	x	x	x	x
C4-DNE-BT65A-I	x	x	x	x	x
C4-DNI-BT65A-E	x	x	x	x	
C4-DNI-BT65A-I	x	x	x	x	
APB-TNE-BT65A-25	x	x	x	x	x

C

CBI	Doosan BMT75				
	Doosan Puma 400, 480 M/LM	Doosan Puma V550 M	Doosan Puma VT750 M, M-2SP		
Article code					
C5-TR/LE-BT75A	x	x	x		
C5-TR/LI-BT75A	x	x			
C5-DNE-BT75A-E	x	x	x		
C5-DNE-BT75A-I	x	x	x		
C5-DNI-BT75A-E	x	x	x		
C5-DNI-BT75A-I	x	x	x		

G

CBI	Doosan BMT85				
	Doosan Puma 600, 700, 800M	Doosan Puma VT900M			
Article code					
C6-TR/LE-BT85A	x	x			
C6-TR/LI-BT85A	x	x			
C6-DNE-BT85A-E	x	x			
C6-DNE-BT85A-I	x	x			
C6-DNI-BT85A-E	x	x			
C6-DNI-BT85A-I	x	x			

H

I

J

Machine adapted clamping units

CBI

BMT65 common interface e.g. Doosan

Metric version

dm_m , size, mm	Coupling size	Ordering code	Dimensions, mm, inch						
			b_2	b_{21}	h_2	l_{1x}	l_{1z}	l_{1z}	
65	C4	C4-TR/LE-BT65A	142	48	96	71	60		3.7
		C4-TR/LE-BT65A-DT	5.591	1.890	3.780	2.795	2.362		
			148	48	96		80		7.6
			5.827	1.890	3.780		3.150		
		C4-TR/LE-BT65A-TT	152	48	137	81	70		4.7
			5.984	1.890	5.394	3.189	2.756		
65	C4	C4-TR/LE-BT65A-YT	144	48	116	73	70		5.2
			5.669	1.890	4.567	2.874	2.756		
		C4-TR/LI-BT65A	117	48	92	70	100	124	6.5
			4.606	1.890	3.622	2.756	3.937	4.882	
		C4-TR/LI-BT65A-SS	100	48	92	20	100	124	6.1
			3.937	1.890	3.622	.787	3.937	4.882	

R = Right hand, L = Left hand

Driven tool holders

dm_m , size, mm	Coupling size	Ordering code	Dimensions, mm, inch						
			b_2	b_{21}	h_2	l_{1x}	l_{1z}	l_{1z}	
65	C4	C4-DNE-BT65A-E	96	48	96		54		4.2
			3.780	1.890	3.780		2.126		
		C4-DNE-BT65A-I	96	48	96		54		4.3
65	C4		3.780	1.890	3.780		2.126		
		C4-DNI-BT65A-E	130.4		96	68	100	140	10
			5.134		3.780	2.677	3.937	5.512	
		C4-DNI-BT65A-I	134.8		96	68	100	140	10.2
			5.307		3.780	2.677	3.937	5.512	

N = Neutral



Spare parts for machine adapted clamping units can be downloaded

www.sandvik.coromant.com

Online catalogues

Download catalogues



Machine adapted clamping units

CBI

BMT75 common interface e.g. Doosan

Metric version

dm_m , size, mm	Coupling size	Ordering code	Dimensions, mm, inch					
			b_2	b_{21}	h_2	l_{1x}	l_{1z}	l_{tz} 
75	C5	C5-TR/LE-BT75A	182	64	112	35		7
			7.165	2.520	4.409	1.378		
75	C5	C5-TR/LI-BT75A	150	64	112	92.5	92	7
			5.906	2.520	4.409	3.642	3.622	

R = Right hand, L = Left hand

Driven tool holders

dm_m , size, mm	Coupling size	Ordering code	Dimensions, mm, inch					
			b_2	b_{21}	h_2	l_{1x}	l_{1z}	l_{tz} 
75	C5	C5-DNE-BT75A-E	112	56	112			6.8
			4.409	2.205	4.409			
			112	56	112			7.2
75	C5	C5-DNI-BT75A-E	150		112	83	106	12.9
			5.906		4.409	3.268	4.173	
			156		112	83	106	13.5
		C5-DNI-BT75A-I	6.142		4.409	3.268	4.173	

N = Neutral

BMT85 common interface e.g. Doosan

Metric version

dm_m , size, mm	Coupling size	Ordering code	Dimensions, mm, inch						
			b_2	b_{21}	h_2	l_{1x}	l_{1z}	l_{tz}	l_{tz} 
85	C6	C6-TR/LE-BT85A	225	84	124	43	35		11.7
			8.858	3.307	4.882	1.693	1.378		
85	C6	C6-TR/LI-BT85A	195	84	124	55	85	127	21.9
			7.677	3.307	4.882	2.165	3.346	5.000	

R = Right hand, L = Left hand

Driven tool holders

dm_m , size, mm	Coupling size	Ordering code	Dimensions, mm, inch						
			b_2	b_{21}	h_2	l_{1x}	l_{1z}	l_{tz}	l_{tz} 
85	C6	C6-DNE-BT85A-E	125	62.5	125		85		11.3
			4.921	2.461	4.921		3.346		
			125	62.5	125		85		11.6
85	C6	C6-DNI-BT85A-E	4.921	2.461	4.921		3.346		
			184		125	104	85	141	22.4
			7.244		4.921	4.094	3.346	5.551	
		C6-DNI-BT85A-I	190		125	104	85	141	23
			7.480		4.921	4.094	3.346	5.551	

N = Neutral

Spare parts for machine adapted clamping units can be downloaded

www.sandvik.coromant.com

Online catalogues

Download catalogues



Which CBI toolholder fits to which Nakamura-Tome NA55A and NA65A

CBI	Nakamura Tome NA55A				
	Nakamura-Tome WT-150, WT-250 II	Nakamura-Tome Super NTJ, NTM ³	Nakamura-Tome Super NTJX	Nakamura-Tome SC-200, SC-250	Nakamura-Tome TW-10, TW-20 (16 stn.)
Article code					
C4-TR/LE-NA55A	x	x	x	x	x
C4-TR/LE-NA55A-DT	x	x		x	
C4-TR/LI-NA55A	x	x		x	x
C3-DNE-NA55-E	x	x	x	x	x
C3-DNE-NA55-I	x	x	x	x	x
C3-DNI-NA55A-E	x	x		x	x
C3-DNI-NA55A-I	x	x		x	x

CBI	Nakamura Tome NA65A				
	Nakamura-Tome WT-300	Nakamura-Tome Super NTX	Nakamura-Tome TW-20 (12 stn.)	Nakamura-Tome SC-300	
Article code					
C4-TR/LE-NA65A	x	x	x	x	
C4-TR/LE-NA65A-DT	x	x		x	
C4-TR/LI-NA65A	x	x	x	x	
C4-DNE-NA65A-E	x	x	x	x	
C4-DNE-NA65A-I	x	x	x	x	
C4-DNI-NA65A-E	x	x	x	x	
C4-DNI-NA65A-I	x	x	x	x	

Machine adapted clamping units

CBI

Nakamura Tome NA55A

Metric version

dm _m , size, mm	Coupling size	Ordering code	Dimensions, mm, inch						
			b ₂	b ₂₁	h ₂	l _{1x}	l _{1z}	l _{1z}	
55	C4	C4-TR/LE-NA55A	129	48	84	25	50		3.4
			5.079	1.890	3.307	.984	1.968		
		C4-TR/LE-NA55A-DT	178	48	84		50		5.2
			7.008	1.890	3.307		1.968		
55	C4	C4-TR/LI-NA55A	96	48	84	25	75	99	4.5
			3.780	1.890	3.307	.984	2.953	3.898	

R = Right hand, L = Left hand

Driven tool holders

dm _m , size, mm	Coupling size	Ordering code	Dimensions, mm, inch						
			b ₂	b ₂₁	h ₂	l _{1x}	l _{1z}	l _{1z}	
55	C3	C3-DNE-NA55A-E	79	39.5	84		50		3
			3.110	1.555	3.307		1.968		
		C3-DNE-NA55A-I	79	39.5	84		50		3.2
			3.110	1.555	3.307		1.968		
55	C3	C3-DNI-NA55A-E	99		84	45	65	100	4.6
			3.898		3.307	1.772	2.559	3.937	
		C3-DNI-NA55A-I	104		84	45	65	100	4.8
			4.094		3.307	1.772	2.559	3.937	

N = Neutral

Nakamura Tome NA65A

Metric version

dm _m , size, mm	Coupling size	Ordering code	Dimensions, mm, inch						
			b ₂	b ₂₁	h ₂	l _{1x}	l _{1z}	l _{1z}	
65	C4	C4-TR/LE-NA65A	149	48	96	25	50		6
			5.866	1.890	3.780	.984	1.968		
		C4-TR/LE-NA65A-DT	198	48	96		50		7.7
			7.795	1.890	3.780		1.968		
65	C4	C4-TR/LI-NA65A	98	48	94	10	90	114	6
			3.858	1.890	3.701	.394	3.543	4.488	

R = Right hand, L = Left hand

Driven tool holders

dm _m , size, mm	Coupling size	Ordering code	Dimensions, mm, inch						
			b ₂	b ₂₁	h ₂	l _{1x}	l _{1z}	l _{1z}	
65	C4	C4-DNE-NA65A-E	100	50	96		53.5		4.6
			3.937	1.968	3.780		2.106		
		C4-DNE-NA65A-I	100	50	96		53.5		4.7
			3.937	1.968	3.780		2.106		
65	C4	C4-DNI-NA65A-E	130.4		96	68	65	105	7.3
			5.134		3.780	2.677	2.559	4.134	
		C4-DNI-NA65A-I	134.8		96	68	65	105	7.5
			5.307		3.780	2.677	2.559	4.134	

N = Neutral

Spare parts for machine adapted clamping units can be downloaded

www.sandvik.coromant.com

Online catalogues

Download catalogues



Machine adapted clamping units

CBI

Okuma OK60A

Metric version

dm_m , size, mm	Coupling size	Ordering code	Dimensions, mm, inch						
			b_2	b_{21}	h_2	l_{1x}	l_{1z}	h_{1y}	
60	C4	C4-TR/LE-OK60A	130	48	95	6			4.6
		C4-TR/LE-OK60A-DT	5.118	1.890	3.740	.236			7.4
		C4-TR/LE-OK60A-YT	6.299	1.890	3.740				4.8
60	C4	C4-TR/LI-OK60A	149	48	103	25		26	4.8
			5.866	1.890	4.055	.984		1.024	
			4.626	1.890	3.740	.689	4.488		

R = Right hand, L = Left hand

Driven tool holders

dm_m , size, mm	Coupling size	Ordering code	Dimensions, mm, inch						
			b_2	b_{21}	h_2	l_{1x}	l_{1z}	l_{1z}	
60	C4	C4-DNE-OK60A-E	120	50	97		54.5		4.6
		C4-DNE-OK60A-I	4.724	1.968	3.819		2.146		4.9
			120	50	97		60		4.9
60	C4	C4-DNI-OK60A-E	144.8		98	85	70	113.2	9.3
		C4-DNI-OK60A-I	5.701		3.858	3.346	2.756	4.457	
			144.8		98	85	70	113.2	9.4
			5.701		3.858	3.346	2.756	4.457	

N = Neutral

Adaptor for parting blades

dm_m , size, mm	Coupling size	Ordering code	Dimensions, mm, inch				
			b_2	b_{21}	f_1	h_2	
60	25	APB-TNE-OK60A-25	131	31	26	100	2.8
			5.158	1.220	1.024	3.937	

N = Neutral

Machine models for OK60A:

LB2000 EX

LB2500EX

LB3000EX



Spare parts for machine adapted clamping units can be downloaded

www.sandvik.coromant.com

Online catalogues

Download catalogues

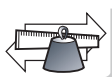

Adaptors for solid boring bars

131

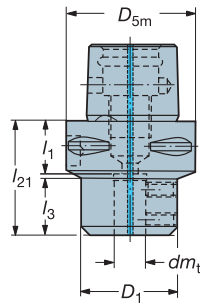
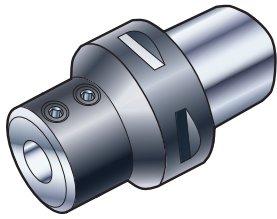
 l_1 = programming length

Metric pilot

Coupling size	Ordering code	Coolant ¹⁾	Dimensions, mm					
			$dm_1^{(2)}$	D_{5m}	D_1	l_1	l_3	l_{21}
C3	C3-131-00035-10	1	10	32	36	15	20	35
	C3-131-00040-12	1	12	32	36	16	24	40
C4	C4-131-00040-10	1	10	40	36	20	19	40
	C4-131-00045-12	1	12	40	36	21	24	45
	C4-131-00050-16	1	16	40	36	18	29	50
C5	C5-131-00045-10	1	10	50	36	25	21	45
	C5-131-00045-12	1	12	50	36	25	22.5	45
	C5-131-00055-16	1	16	50	36	23	31	55

1) 1 = coolant through centre

2) Tolerance = H8

131

G

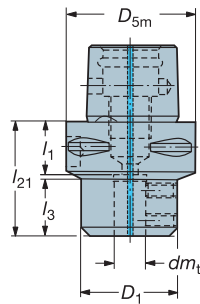
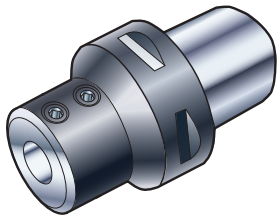
 l_1 = programming length

H

Inch pilot

Coupling size	Ordering code	Coolant ¹⁾	Dimensions, inch					
			$dm_1^{(2)}$	D_{5m}	D_1	l_1	l_3	l_{21}
C3	C3-131-00050-250	1	.250	1.260	1.180	.901	.790	1.970
	C3-131-00050-500	1	.500	1.260	1.420	.591	1.020	1.970
	C3-131-00050-625	1	.625	1.260	1.420	.591	1.260	1.970
C4	C4-131-00050-250	1	.250	1.575	1.420	1.181	1.070	1.970
	C4-131-00050-375	1	.375	1.575	1.420	1.181	1.130	1.970
	C4-131-00050-500	1	.500	1.575	1.420	95.000	1.130	1.970
	C4-131-00050-625	1	.625	1.575	1.420	.709	1.130	1.970
	C4-131-00060-750	1	.750	1.575	1.420	.830	1.420	2.360
	C4-131-00091-1000	1	1.000	1.575	2.284	.772	2.811	3.583
C5	C5-131-00060-375	1	.375	1.968	1.420	1.575	1.575	2.360
	C5-131-00060-500	1	.500	1.968	1.420	1.340	1.575	2.360
	C5-131-00060-625	1	.625	1.968	1.420	1.100	1.575	2.360
	C5-131-00060-750	1	.750	1.968	1.420	.830	1.575	2.360
	C5-131-00070-1000	1	1.000	1.968	2.130	.790	1.970	2.760
	C5-131-00115-1500	1	1.500	1.968	2.870	1.090	3.440	4.528
C6	C6-131-00065-375	1	.375	2.480	1.420	1.170	.790	2.560
	C6-131-00065-500	1	.500	2.480	1.420	1.170	1.020	2.560
	C6-131-00065-625	1	.625	2.480	1.420	1.170	1.260	2.560
	C6-131-00065-750	1	.750	2.480	1.420	1.270	1.540	2.660
	C6-131-00075-1000	1	1.000	2.480	2.130	.950	2.040	2.950
	C6-131-00105-1500	1	1.500	2.480	2.870	.690	3.440	4.130

1) 1 = coolant through centre

2) Tolerance = H8

J



G91



G6



G2



J2

Blanks for production of cutting units

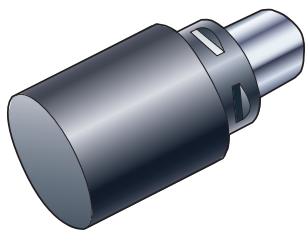

Coromant Capto blanks have a "soft" front, which allows machining of special shapes.

The material is 25 CRMo4, low alloy steel.
Tensile strength 700 N/mm². HB 270 – 352.

Equilibrium temperature: 840–870°C

Cooling medium: Polymer

Tempering: 1 hour 200°C

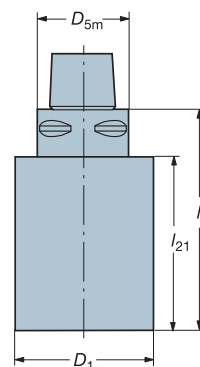

Note: If localized hardening is required, induction type hardening is to be used. Max. hardness which can be attained with this material 50 HRC.

Coupling size	Ordering code	Dimensions, millimeter, inch (mm, in.)							
		D_{5m} mm	D_{5m} in.	D_1 mm	D_1 in.	l_7 mm	l_7 in.	l_{21} mm	l_{21} in.
C3	C3-NR-040110-B	32	1.260	40	1.575	110	4.331	95	3.740
	C3-NR-050125-B	32	1.260	50	1.968	125	4.921	110	4.331
	C3-NR-070060-B	32	1.260	70	2.756	60	2.362	45	1.772
	C3-NR-090070-B	32	1.260	90	3.543	70	2.756	55	2.165
C4	C4-NR-040095-B	40	1.575	41	1.614	95	3.740	75	2.953
	C4-NR-060165-B	40	1.575	60	2.362	165	6.496	145	5.709
	C4-NR-080075-B	40	1.575	80	3.150	75	2.953	55	2.165
	C4-NR-100085-B	40	1.575	100	3.937	85	3.346	65	2.559
C5	C5-NR-050125-B	50	1.968	50	1.968	125	4.921	105	4.134
	C5-NR-075175-B	50	1.968	75	2.953	175	6.890	155	6.102
	C5-NR-090080-B	50	1.968	90	3.543	80	3.150	60	2.362
	C5-NR-110090-B	50	1.968	110	4.331	90	3.543	70	2.756
C6	C6-NR-075195-B	63	2.480	75	2.953	195	7.677	173	6.811
	C6-NR-110085-B	63	2.480	110	4.331	85	3.346	63	2.480
C8	C8-NR-080200-B	80	3.150	80	3.150	200	7.874	170	6.693
	C8-NR-120160-B	80	3.150	120	4.724	160	6.299	130	5.118
	C8-NR-130090-B	80	3.150	130	5.118	90	3.543	60	2.362
C10	C10-NR-100200-B	100	3.937	100	3.937	200	7.874	164	6.457
	C10-NR-160120-B	100	3.937	160	6.299	120	4.724	84	3.307



G6



G2



J2

A

Extension adaptor

391.01

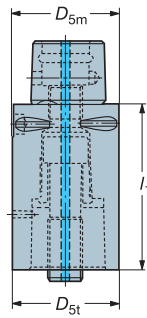
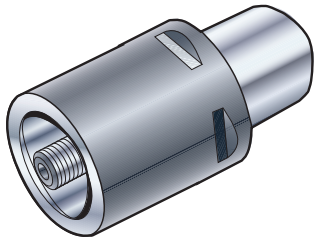
 l_1 = programming length

B

C

Coupling size		Ordering code	Coolant ¹⁾	Dimensions, millimeter, inch (mm, in.)						
Machine side	Tool side			D_{5m} mm	D_{5m} in.	D_{5t} mm	D_{5t} in.	l_1 mm	l_1 in.	
C3	C3	C3-391.01-32 060A	1	32	1.260	32	1.260	60	2.362	0.4
		C3-391.01-32 080A	1	32	1.260	32	1.260	80	3.150	0.5
C4	C4	C4-391.01-40 060A	1	40	1.575	40	1.575	60	2.362	0.5
		C4-391.01-40 080A	1	40	1.575	40	1.575	80	3.150	0.7
C5	C5	C5-391.01-50 080A	1	50	1.968	50	1.968	80	3.150	1.1
		C5-391.01-50 100A	1	50	1.968	50	1.968	100	3.937	1.4
C6	C6	C6-391.01-63 100A	1	63	2.480	63	2.480	100	3.937	2.2
		C6-391.01-63 140A	1	63	2.480	63	2.480	140	5.512	3.1
C8	C8	C8-391.01-80 100A	1	80	3.150	80	3.150	100	3.937	3.6
		C8-391.01-80 125A	1	80	3.150	80	3.150	125	4.921	4.6
C10	C10	C10-391.01-100 140	1	100	3.937	100	3.937	140	5.512	8.5

¹⁾ 1 = coolant through centre

G

Short version, for segment clamping only

391.01

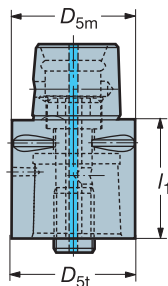
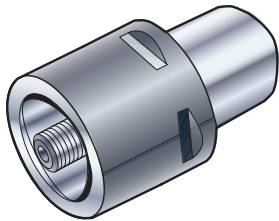
**Note!**

Not possible to use together with basic holders using centre bolt clamping.

 l_1 = programming length

H

I

Coupling size		Ordering code	Coolant ¹⁾	Dimensions, millimeter, inch (mm, in.)						
Machine side	Tool side			D_{5m} mm	D_{5m} in.	D_{5t} mm	D_{5t} in.	l_1 mm	l_1 in.	
C3	C3	C3-391.01-32 035	1	32	1.260	32	1.260	35	1.378	0.2
C4	C4	C4-391.01-40 040	1	40	1.575	40	1.575	40	1.575	0.4
C5	C5	C5-391.01-50 050	1	50	1.968	50	1.968	50	1.968	0.9
C6	C6	C6-391.01-63 060	1	63	2.480	63	2.480	60	2.362	1.3
C8	C8	C8-391.01-80 065	1	80	3.150	80	3.150	65	2.559	2.3

¹⁾ 1 = coolant through centre

J



G92



G6



G2



J2

Reduction adaptor

391.02

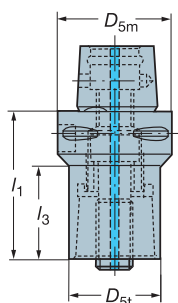
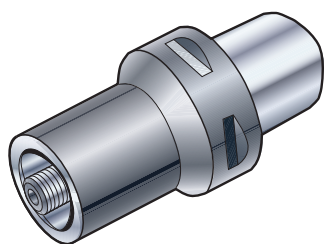

Design 1

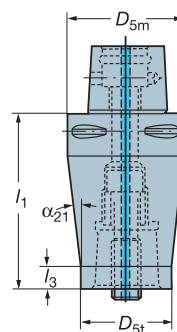

Design 2

 l_1 = programming length

Coupling size				Dimensions, millimeter, inch (mm, in.)										
Design	Machine side	Tool side	Ordering code	Coolant ¹⁾	D_{5m} mm	D_{5m} in.	D_{5t} mm	D_{5t} in.	l_1 mm	l_1 in.	l_3 mm	l_3 in.	α_{21}	$\frac{m}{kg}$
1	C4	C3	C4-391.02-32 055A	1	40	1.575	32	1.260	55	2.165	31	1.220		0.5
2			C4-391.02-32 070A	1	40	1.575	32	1.260	70	2.756	12	.472	6.0°	0.6
1	C5	C3	C5-391.02-32 060A	1	50	1.968	32	1.260	60	2.362	34.8	1.370		0.6
1		C4	C5-391.02-40 065A	1	50	1.968	40	1.575	65	2.559	40	1.575		0.8
2			C5-391.02-40 085A	1	50	1.968	40	1.575	85	3.346	12	.472	5.4°	1.1
1	C6	C3	C6-391.02-32 070A	1	63	2.480	32	1.260	70	2.756	39	1.535		1.1
1		C4	C6-391.02-40 080A	1	63	2.480	40	1.575	80	3.150	51.4	2.024		1.2
1		C5	C6-391.02-50 080A	1	63	2.480	50	1.968	80	3.150	51.5	2.028		1.5
2			C6-391.02-50 110A	1	63	2.480	50	1.968	110	4.331	12	.472	4.9°	2.2
1	C8	C3	C8-391.02-32 060A	1	80	3.150	32	1.260	60	2.362	29.3	1.154		1.7
1		C4	C8-391.02-40 070A	1	80	3.150	40	1.575	70	2.756	36.5	1.437		1.9
1		C5	C8-391.02-50 080A	1	80	3.150	50	1.968	80	3.150	49.3	1.941		2.2
1		C6	C8-391.02-63 080A	1	80	3.150	63	2.480	80	3.150	53.1	2.091		2.5
2			C8-391.02-63 120A	1	80	3.150	63	2.480	120	4.724	12	.472		4.0
1	C10	C3	C10-391.02-32 085	1	100	3.937	32	1.260	85	3.346	29.4	1.158		4.0
1		C4	C10-391.02-40 090	1	100	3.937	40	1.575	90	3.543	36.7	1.445		4.1
1		C5	C10-391.02-50 095	1	100	3.937	50	1.968	95	3.740	44.6	1.756		4.3
1		C6	C10-391.02-63 095	1	100	3.937	63	2.480	95	3.740	48.3	1.902		4.5
1		C8	C10-391.02-80 100	1	100	3.937	80	3.150	100	3.937	58.2	2.291		5.1

¹⁾ 1 = coolant through centre

Short version, for segment clamping only

391.02

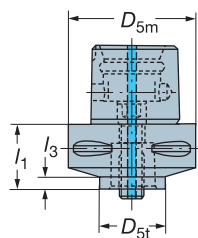
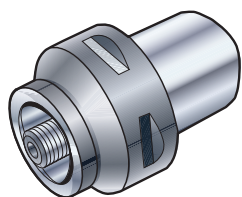
**Note!** Not possible to use together with basic holders using centre bolt clamping. l_1 = programming length

Coupling size				Dimensions, millimeter, inch (mm, in.)									
Machine side	Tool side	Ordering code	Coolant ¹⁾	D_{5m} mm	D_{5m} in.	D_{5t} mm	D_{5t} in.	l_1 mm	l_1 in.	l_3 mm	l_3 in.	$\frac{m}{kg}$	
C5	C3	C5-391.02-32 033	1	50	1.968	32	1.260	33	1.299	10	.394	0.5	
	C4	C5-391.02-40 040	1	50	1.968	40	1.575	40	1.575	18	.709	0.6	
C6	C3	C6-391.02-32 032	1	63	2.480	32	1.260	32	1.260	6	.236	0.8	
	C4	C6-391.02-40 040	1	63	2.480	40	1.575	40	1.575	11	.433	0.9	
	C5	C6-391.02-50 050	1	63	2.480	50	1.968	50	1.968	26.5	1.043	1.0	
C8	C5	C8-391.02-50 045	1	80	3.150	50	1.968	45	1.772	10	.394	1.8	
	C6	C8-391.02-63 055	1	80	3.150	63	2.480	55	2.165	20	.787	2.0	
C10	C6	C10-391.02-63 055	1	100	3.937	63	2.480	55	2.165	14	.551	3.2	
	C8	C10-391.02-80 065	1	100	3.937	80	3.150	65	2.559	25.4	1.000	3.5	

¹⁾ 1 = coolant through centre

G92



G6



G2



J2

Reduction adaptor

180° rotated polygon

Short version, for segment clamping only

391.01R

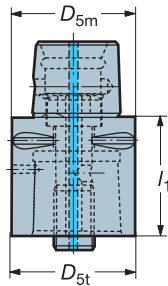
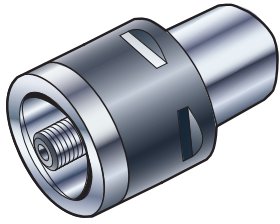

Note!

Not possible to use together with basic holders using centre bolt clamping.

l_1 = programming length

C

Coupling size		Ordering code	Coolant ¹⁾	Dimensions, mm, inch			
Machine side	Tool side			D_{5m}	D_{5t}	l_1	
C5	C5	C5-391.01R-50 050	1	50 1.968	50 1.968	50 1.968	0.9
C6	C6	C6-391.01R-63 060	1	63 2.480	63 2.480	60 2.362	1.3
C8	C8	C8-391.01R-80 065	1	80 3.150	80 3.150	65 2.559	2.3

¹⁾ 1 = coolant through centre

G

Reduction adaptor

180° rotated polygon

Short version, for segment clamping only

391.02R

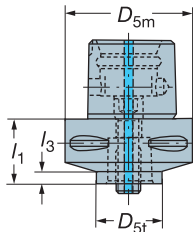
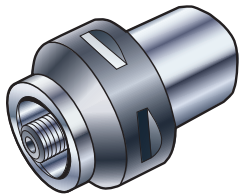

Note!

Not possible to use together with basic holders using centre bolt clamping.

l_1 = programming length

H

Coupling size		Ordering code	Coolant ¹⁾	Dimensions, mm, inch				
Machine side	Tool side			D_{5m}	D_{5t}	l_1	l_3	
C8	C6	C8-391.02R-63 055	1	80 3.150	63 2.480	55 2.165	20 .787	2.0

¹⁾ 1 = coolant through centre

I

J



Coromant Capto® short adaptor for exchangeable head

Without gripper grooves for manual tool change in turning centres

Cx-391.EH
Cx-A391.EH

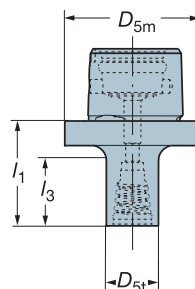
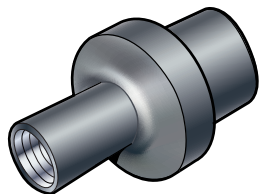

l_1 = programming length

Metric version

Coromant Capto size	Coupling size	Ordering code	Coolant ¹⁾	Dimensions, mm				
				D_{5m}	D_{5t}	l_1	l_3	$\frac{kg}{kg}$
C3	E10	C3-391.EH-10 026	1	32	9.6	26	13	0.1
	E12	C3-391.EH-12 029	1	32	11.6	29	16	0.1
C4	E10	C4-391.EH-10 026	1	40	9.6	26	13	0.2
	E12	C4-391.EH-12 029	1	40	11.6	29	16	0.2
	E16	C4-391.EH-16 035	1	40	15.4	35	22	0.2
C5	E10	C5-391.EH-10 026	1	50	9.6	26	13	0.3
	E12	C5-391.EH-12 029	1	50	11.6	29	16	0.3
	E16	C5-391.EH-16 035	1	50	15.4	35	22	0.3

Inch version

Coromant Capto size	Coupling size	Ordering code	Coolant ¹⁾	Dimensions, inch				
				D_{5m}	D_{5t}	l_1	l_3	$\frac{lbs}{kg}$
C3	E10	C3-A391.EH-10 025	1	1.260	.360	.984	.472	0.2
	E12	C3-A391.EH-12 031	1	1.260	.480	1.220	.709	0.2
C4	E10	C4-A391.EH-10 025	1	1.575	.360	.984	.472	0.4
	E12	C4-A391.EH-12 031	1	1.575	.480	1.220	.709	0.4
	E16	C4-A391.EH-16 034	1	1.575	.606	1.339	.827	0.4
C5	E10	C5-A391.EH-10 025	1	1.968	.360	.984	.472	0.6
	E12	C5-A391.EH-12 031	1	1.968	.480	1.220	.709	0.6

¹⁾ 1 = coolant through centre

For complete assortment of adaptors and cutting heads for CoroMill® 316, see chapter D and G in Main catalogue for milling, drilling and boring tools.

Main spare parts

Coupling size	Key	Torque wrench head ¹⁾	Torque wrench head for 2-edge end mill ¹⁾	Torque value		Torque wrench ¹⁾	Torque range	
				Nm	In-lbs		Nm	In-lbs
E10	5680 093-01	5680 089-01	5680 089-06	12	106	5680 088-01	10-20	88-177
E12	5680 093-02	5680 089-02	5680 089-07	15	132	5680 088-01	10-20	88-177
E16	5680 093-03	5680 089-03	5680 089-08	30	265	5680 088-02	25-65	221-575

¹⁾ Accessories, must be ordered separately

Note!

The nut is not a standard ER nut and therefore not exchangeable with the spare part series 5533 050-0X. The nut is always included in the package



G6



G2



J2

ER collet chuck adaptor, short

For driven tool holders

No gripper grooves

DIN 6499/ 391.14

B

☉ Balanced by design

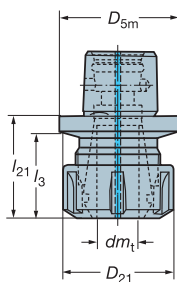
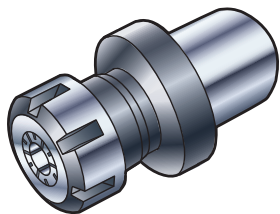

Short design

Accessories

393.14

Not delivered with the tool, must be ordered separately.



See Main catalogue for milling, drilling and boring tools.

C

Note: For segment clamping only. Can't be used in basic holders and extensions/reductions.

Not for automatic tool change as have no gripper grooves

Coromant Capto® short (for manual tool change in turning centres)

Coupling size	Ordering code	Coolant ¹⁾	Dimensions, millimeter, inch (mm, in.)												Collet size	Balanced by design	
			D_{5m} mm	D_{5m} in.	dm_t min mm	dm_t min in.	dm_t max mm	dm_t max in.	D_{21} mm	D_{21} in.	l_3 mm	l_3 in.	l_{21} mm	l_{21} in.			$\frac{m}{kg}$
C3	C3-391.14-20 036	1	32	1.260	1	.039	13	.512	35	1.378			36	1.417	0.3	ER 20	☉
C4	C4-391.14-20 035	1	40	1.575	1	.039	13	.512	35	1.378	27	1.063	35	1.378	0.2	ER 20	☉
	C4-391.14-25 038	1	40	1.575	1	.039	16	.630	42	1.654			38	1.496	0.3	ER 25	☉
C5	C5-391.14-32 045	1	50	1.968	2	.079	20	.787	50	1.968			45	1.772	0.5	ER 32	☉

¹⁾ 1 = coolant through centre

G

H

I

J



G93



G6



G2



J2

Tap adaptors

Collet type with external coolant supply

391.60B

Short design, floating for turning centres

Without gripper grooves for manual tool change

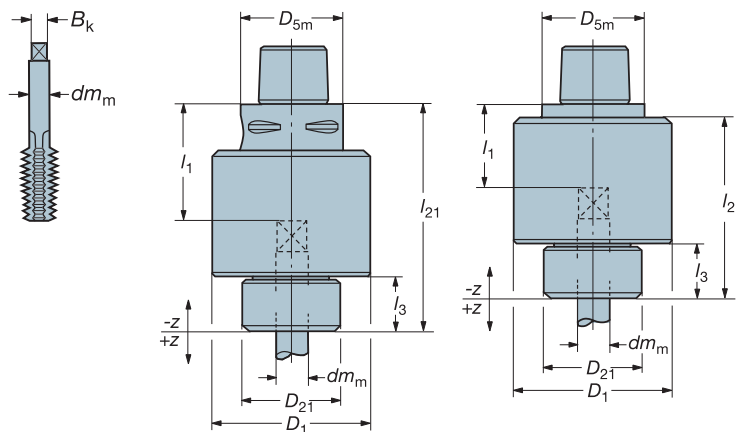
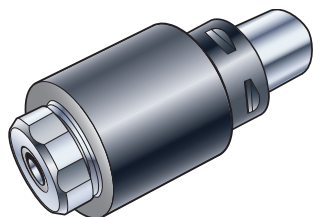

Note: Only for segment clamping.

l_1 = programming length

Tap range		Coupling size	Ordering code	Coolant ¹⁾	Tap shank dimensions, mm, inch			Dimensions, mm, inch										Torque Nm ²⁾
min	max				dm_m min	dm_m max	B_k min	B_k max	D_{5m}	D_1	D_{21}	l_1	l_3	l_{21}	-z	+z	$\frac{\sigma}{R_{15}}$	
M4	M12	C3	C3-391.60B-01 062A ³⁾	0	3.5	10	2	8	32	50	31	25.5	18	62	2	10	0.7	35
M4	M12			0	.138	.394	.079	.315	1.260	1.968	1.220	1.004	.709	2.441	.079	.394		
M4	M12	C4	C4-391.60B-01 062A ³⁾	0	3.5	10	2	8	40	50	31	25.5	18	62	2	10	0.9	35
M4	M12			0	.138	.394	.079	.315	1.575	1.968	1.220	1.004	.709	2.441	.079	.394		
M4	M12		C4-391.60B-01 079A	0	3.5	10	2	8	40	50	31	42	18	79	2	10	0.7	35
M4	M12			0	.138	.394	.079	.315	1.575	1.968	1.220	1.654	.709	3.110	.079	.394		
M5	M16	C5	C5-391.60B-02 062A ³⁾	0	2.8	13	2	10	50	50	40	22	19	62	2	10	1.0	60
M5	M16			0	.110	.512	.079	.394	1.968	1.968	1.575	.866	.748	2.441	.079	.394		
M5	M16		C5-391.60B-02 074A	0	2.8	13	2	10	50	50	40	34	19	74	2	10	1.0	60
M5	M16			0	.110	.512	.079	.394	1.968	1.968	1.575	1.339	.748	2.913	.079	.394		

1) 0 = no coolant

2) Max allowed tightening torque

3) For Driven Tool Holders. Without slots for gripper.

Collets must be ordered separately, see below.

Collets

Collet size	dm_m mm (inch)	Ordering code	Shank ¹⁾ DIN 374	Suitable for:
1	3.5-6.5 (.138-.256)	391.60A-OZ J421	M4-M8 (0-1/4)	Cx-391.60B ...01 xxxA
2	6.5-10 (.256-.394)	391.60A-OZ J422	M6-M12 (1/4-9/16)	...01 xxxA
3	2.8-7 (.110-.276)	391.60A-OZ J440	M5-M10 (0-1/4)	...02 xxxA
4	7-13 (.276-.512)	391.60A-OZ J443	M7-M16 (5/16-5/8)	...02 xxxA
5	10-16 (.394-.630)	391.60A-OZ J461	M10-M16 (9/16-3/4)	...03 xxxA
6	16-23 (.630-.906)	391.60A-OZ J462	M20-M30 (13/16-1 1/8)	...03 xxxA

1) For other standards, check shank dimensions B_k and dm_m



G94



G6



G2



J2

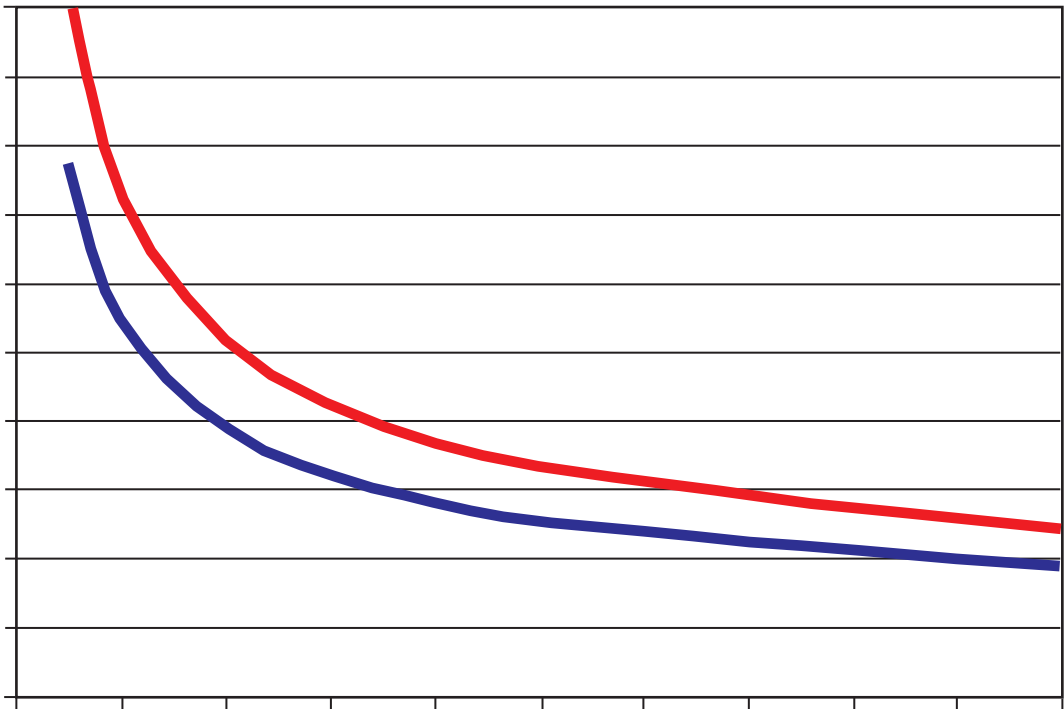

Accessories

	Page		Page
Fixtures	G62	Pre-measuring fixture	G71
Grease nipple	G64	Master setting gauges	G72
Push button operated valve	G64	Alignment tool	G72
Assembly tool	G64		
Extension key, Centre bolt clamping	G65		
Torque wrench for tool changing	G65		
Tightening torque recommendations	G66		
Extracting tool for clamping units	G67		
Tools for disassembling polygon socket	G67		
Cover plug	G67		
Balancing tool	G67		
Cassettes with tapered polygon seating	G69		
Coolant tubes for Coromant Capto®	G68		

Spare parts

	Page
Manually operated clamping units	
Type 2085	G73
Type 2000	G74
Type 3000	G74
Type 2080	G75
Type 2090	G76
Round shank type	G77
VDI Angled design, DIN 69880	G78
VDI Straight design, DIN 69880	G79
CDI external	G80
CDI internal	G80
Hydraulically operated clamping units	
Type 5010	G88
Type 5110	G90
Type 5210	G89
Coromant Capto® adaptors	
Coromant Capto® adaptor for solid boring bar	G91
Extension/reduction adaptors	G92
Collet chuck adaptors	G93
Tap adaptors	G94

For spare parts for Coromant Capto® multi-task machining tools, see chapter H

Assembly fixture

for mounting and dismounting of modular tools

391.500

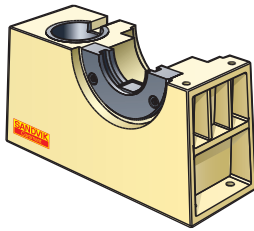

Fixture body

Ordering code: 391.500

391.501

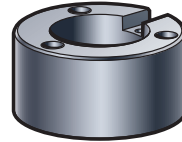

Fixture body

Ordering code: 391.501

Ordering code



Sleeve	For holder type, size
391.540-C3	Coromant Capto Size C3
391.540-C4	Coromant Capto Size C4
391.540-C5	Coromant Capto Size C5
391.540-C6	Coromant Capto Size C6
391.540-C8	Coromant Capto Size C8
391.540-C10	Coromant Capto Size C10
391.540-HA05	HSK 50 Form A/C
391.540-HA06	HSK 63 Form A/C
391.540-HA08	HSK 80 Form A/C
391.540-HA10	HSK 100 Form A/C
391.540-50	MAS-BT 50/CAT/ISO
391.540-30	MAS-BT 30/CAT/ISO
391.540-40	MAS-BT 40/CAT/ISO

Ordering code



Flange	Collar	For holder type, size
391.510-140 50	391.530-C3	Coromant Capto Size C3
391.510-140 50	391.530-C4	Coromant Capto Size C4
391.510-140 50	391.530-C5	Coromant Capto Size C5
391.510-140 50	391.530-C6	Coromant Capto Size C6
391.510-140 50	391.530-C8	Coromant Capto Size C8
	391.530-C10*	Coromant Capto Size C10 and C8X
391.510-HA05		HSK 50 Form A
391.510-HA06		HSK 63 Form A
391.510-HA08		HSK 80 Form A
391.510-HA10		HSK 100 Form A
391.510-HA12		HSK 125 Form A
391.510-55 30		MAS-BT 30
391.510-55 40		MAS-BT 40
391.510-55 50		MAS-BT 50
391.510-562-40		BIG PLUS, MAS BT 40
391.510-562-50		BIG PLUS, MAS BT 50
391.510-140 40		DIN 69871/40, ANSIB 5.50-40, ISO7388/1-40, CAT 40
391.510-140 50		DIN 69871/50, ANSIB 5.50-40, ISO7388/1-50, CAT 50
391.510-540 40		BIG PLUS DIN69871/1-40, BIG PLUS 7388/1-40, CAT 40
391.510-540 50		BIG PLUS DIN69871/1-50, BIG PLUS 7388/1-50, CAT 50
391.510-00 40		DIN 2080-40/NMTB 40
391.510-00 50		DIN 2080-50/NMTB 50
391.510-140 50	391.530-50	Varilock size 50
391.510-140 50	391.530-63	Varilock size 63
391.510-140 50	391.530-80	Varilock size 80

Note: Key is delivered with the sleeve.
Assembly fixture 391.500

Fixture 391.501 for maintenance of tools with Coromant Capto® and HSK couplings

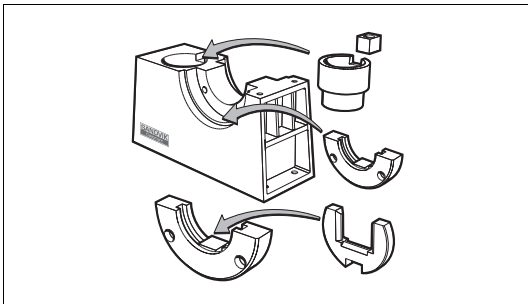

Choose flange, collar and sleeve to suit tool to be assembled.

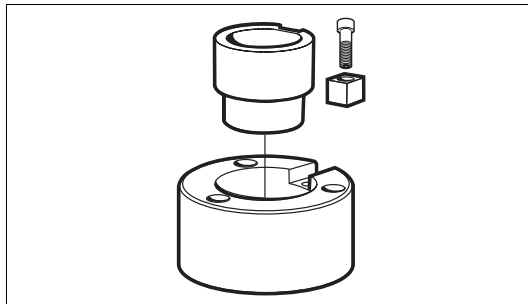

Choose sleeve to suit coupling.
The fixture should be fastened to the bench with three socket head screws (not delivered with fixture)

Assembly fixture

for assembling and dismantling basic holders
Pneumatically operated
391.200

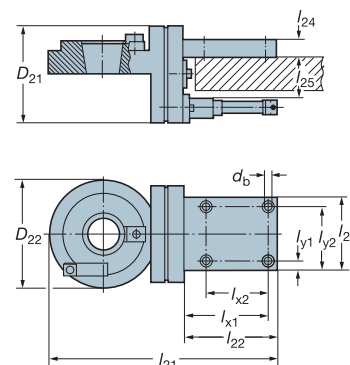
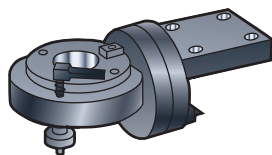

Note!

Assembly fixture 391.200-xx includes foot pedal.

Instructions are enclosed with fixture.

Air supply of 6 bar (85 lbs/in²) is required.

Size		Ordering code	Dimensions, mm, inch												
Taper	HSK		d_b	D_{21}	D_{22}	l_{21}	l_{22}	l_{23}	l_{24}	l_{25}	l_{x1}	l_{x2}	l_{y1}	l_{y2}	
40	-	391.200-40	11	160	180	370	150	120	30	67	135	100	15	105	20
			.433	6.299	7.087	14.567	5.906	4.724	1.181	2.637	5.315	3.737	.590	4.134	
45	-	391.200-45	11	160	180	370	150	120	30	67	135	100	15	105	20
			.433	6.299	7.087	14.567	5.906	4.724	1.181	2.637	5.315	3.737	.590	4.134	
50	-	391.200-50	11	160	180	370	150	120	30	67	135	100	15	105	20
			.433	6.299	7.087	14.567	5.906	4.724	1.181	2.637	5.315	3.737	.590	4.134	
-	50	391.200-H050	11	160	180	370	150	120	30	67	135	100	15	105	20
			.433	6.299	7.087	14.567	5.906	4.724	1.181	2.637	5.315	3.737	.590	4.134	
-	63	391.200-H063	11	160	180	370	150	120	30	67	135	100	15	105	20
			.433	6.299	7.087	14.567	5.906	4.724	1.181	2.637	5.315	3.737	.590	4.134	
-	100	391.200-H100	11	160	180	370	150	120	30	67	135	100	15	105	20
			.433	6.299	7.087	14.567	5.906	4.724	1.181	2.637	5.315	3.737	.590	4.134	

Grease nipple

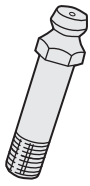

Size	Ordering code
C3 – C8	5692 012-01

Push button operated valve



Requirement specifications:
Working pressure: max. 100 bar

For information about pocket dimensions, see Metalcutting Technical guide or contact your nearest Sandvik Coromant representative.

Ordering code: C-PBOV-01

Assembly tool

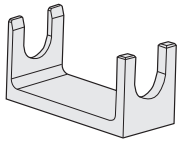

Tool for assembly/disassembly of clamping mechanism for clamping unit type NC2000

Coromant Capto® size	Ordering code
C3	C3-AT2000-01
C4	C4-AT2000-01
C5	C5-AT2000-01

Assembly tools

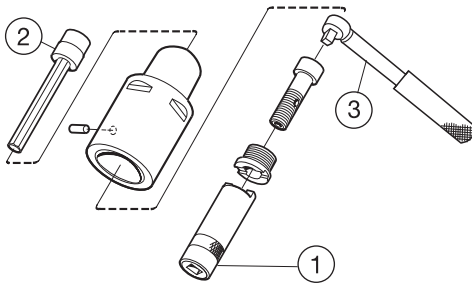

All these accessories are supplied to separate order, and we recommend that they are ordered with the first Coromant Capto parts.

Coupling size	Retaining nut spanner	Extension key	Torque wrench
C3	5680 065-13	5680 015-05	C-TK-02
C4	5680 065-10	5680 015-05	C-TK-02
C5	5680 065-11	5680 015-01	C-TK-02
C6-C8	5680 065-12	5680 015-02	C-TK-02
C10	5680 065-14	5680 015-06	C-TK-04

Extension key, Centre bolt clamping

C-TK-04
80-400 Nm
60-295 ft-lbs

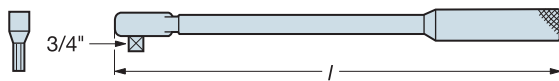

Coupling size	Recommended clamping torque		Ordering code	Key adaptor size	Spare parts	
	Nm	ft-lbs				Torque wrench
C10	80-400	60-295	C-TK-04	683 (26.9) mm	17 mm	5680 015-06

Torque wrench for tool changing

C-TK-01
20-100 Nm
15-74 ft-lbs



C-TK-02
40-200 Nm
30-148 ft-lbs



C-TK-03

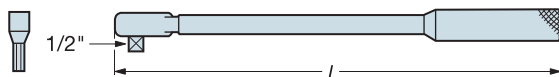

Coupling size	Recommended clamping torque		Ordering code	Key adaptor size	Spare parts	
	Nm	ft-lbs				Torque wrench
C3	35	26	BT-TK-02	8 mm	5680 035-05	
C4	50	37	C-TK-01	345 mm	10 mm	5680 035-06
C5	70	52	C-TK-01	345 mm	12 mm	5680 035-07
C6	90	66	C-TK-01	345 mm	12 mm	5680 035-07
C8	130	96	C-TK-02	440 mm	12 mm	5680 035-07
C10	285	210	C-TK-03	548 (21.6) mm	17 mm	5680 035-10

To be calibrated according to ISO 6789, accuracy within 4%

Tightening torque recommendations

Coromant Capto® tightening torque:

Manual clamping units type NC2000 and NC3000

B

Coupling size	Torque Nm	ft-lbs
C3	35	26
C4	50	37
C5	70	52

Coromant Capto® tightening torque:

Manual clamping units and driven tool holders with camshaft mechanism

C

Coupling size	Torque Nm	ft-lbs
C3	35	26
C4	50	37
C5	70	52
C6	90	66
C8	130	96
C10	285	210

G

Coromant Capto® required pressure:

Hydro-mechanical clamping units type 5000

Coupling size	Clamping Pressure bar (PSI)	Ejecting Pressure bar (PSI)
C4	100 (1450)	100 (1450)
C5	80 (1160)	80 (1160)
C6	80 (1160)	80 (1160)
C8	80 (1160)	80 (1160)
C10	80 (1160)	80 (1160)

Required oil flow in all cases: 6 l/min

H

Coromant Capto® basic holders

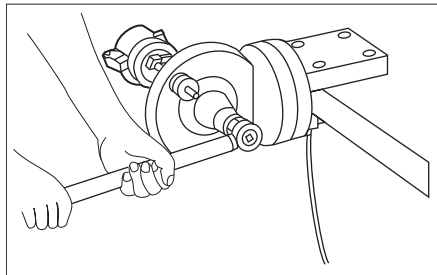

Centre bolt clamping

Coupling size	Torque Nm	ft-lbs
C3	45	33
C4	55	40
C5	95	70
C6	170	125
C8	170	125
C10	380	277

J

Extracting tool

for disassembling the polygon socket on manual and automatic clamping units

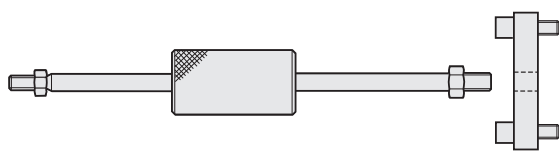

Extracting tool

Withdrawal tool

Coupling size	Ordering code
C3	CC-ET-01
C4	CC-ET-01
C5	CC-ET-02
C6	CC-ET-02
C8	CC-ET-02

Note: Withdrawal tool to be ordered separately.

Withdrawal tool

To remove polygone sleeve from clamping units can be used together with CC-ET-01/02

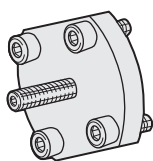

Coupling size	Ordering code	Spare parts	
		Centre screw	Peripheral screw
C3	C3-WDT-01M	3214 030-463	5512 040-03
C4	C4-WDT-01M	3214 030-464	5512 040-04
C5	C5-WDT-01M	3214 030-516	5512 040-05
C6	C6-WDT-01M	3214 030-516	5512 040-06
C8	C8-WDT-01	3214 030-516	5512 072-01

Cover plug

CP-11

CP-01

CPA-01

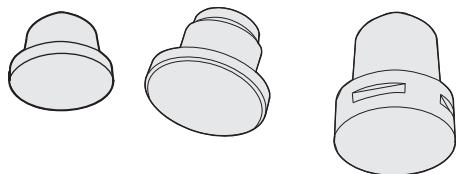

Coupling size	Ordering code		
	Manual unit	Automatic unit	Type 3000
C3	C3-CP-01	-	C3-CP-11
C4	C4-CP-01	C4-CPA-01	C4-CP-11
C5	C5-CP-01	C5-CPA-01	C5-CP-11
C6	C6-CP-01	C6-CPA-01	-
C8	C8-CP-01	C8-CPA-01	-
C10	-	C10-CPA-01	-

Balancing tool

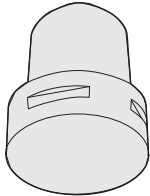
	Coupling size	Ordering code
Cx-BAT-01 	C3	C3 - BAT - 01
	C4	C4 - BAT - 01
	C5	C5 - BAT - 01
	C6	C6 - BAT - 01
	C8	C8 - BAT - 01
	C10	C10 - BAT - 01

Coolant tubes for Coromant Capto®

Cx-CT for Coromant Capto®

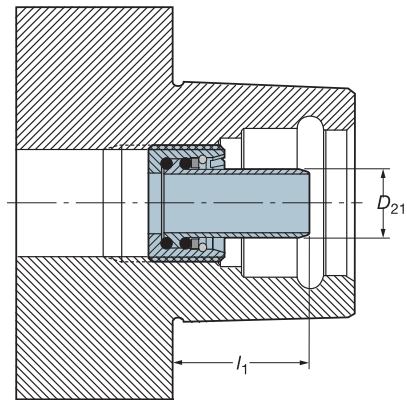

The requirement for use of coolant tubes is machine related, see machine information before installing.

Ensure the clamping device and/or machine are able to accept/handle the coolant tube before using.

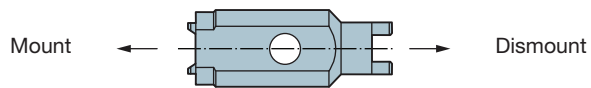

Please refer to M/C manual

Safe control

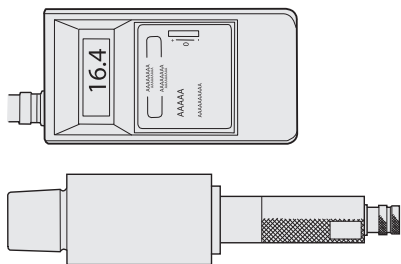

The safe control is used for measuring the clamping force of a machine's clamping system. If the clamping force is too low, the dynamic reaction between spindle and tool deteriorates.

Contact your local Sandvik representative for more information.

Cassettes with tapered polygon seating

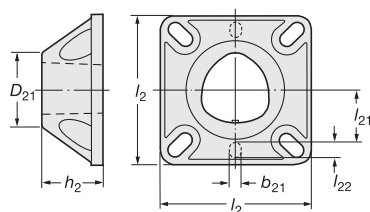
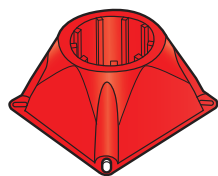

-4000
Plastic storage cassettes (red)

-6000-B

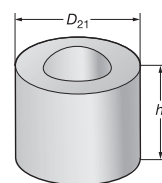

Aluminium cassette blanks

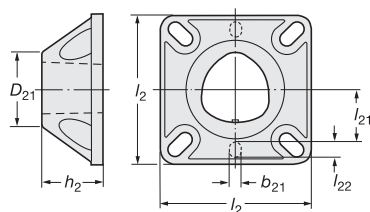
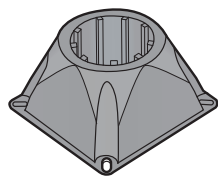

-5000
High grade plastic in-machine tool storage (black)

Coupling size	Ordering code	Dimensions, mm, inch						
		b_{21}	D_{21}	h_2	l_2	l_{21}	l_{22}	
C3	C3-C-4000	-	32	26	65	-	-	All plastic cassettes conforming to hole pattern 17 mm, 20 mm, 25 mm and 1". High grade plastic. Red colour. To be used: - alone for upright storage - with mechanism type PL-01 for horizontal or upright position.
C4	C4-C-4000	6	50	39	74	26	8	
C5	C5-C-4000	6	50	39	74	26	8	
C6	C6-C-4000	8	80	63	116	41	10	
C8	C8-C-4000	8	80	63	116	41	10	
C4	C4-C-5000	6	50	39	74	26	8	
C5	C5-C-5000	6	50	39	74	26	8	
C6	C6-C-5000	8	80	63	116	41	10	
C8	C8-C-5000	8	80	63	116	41	10	High grade re-inforced black plastic. For in-machine tool storage with mechanism AL-01.
C10	C10-C-5000	8	100	80	150	60	68	
C6	C6-C-6000-B	-	120	63	-	-	-	
C8	C8-C-6000-B	-	120	63	-	-	-	Aluminium cassette blanks for individual adaptation. To be used with AL-01.
C10	C10-C-6000-B	-	138	80	-	-	-	
			5.433	3.150				

Locking mechanism for cassettes

-PL-01

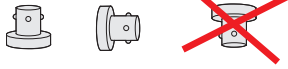
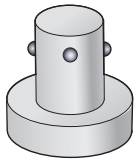

Passive locking mechanism

For vertical upwards and horizontal storage. NEVER upside down storage.

-AL-01

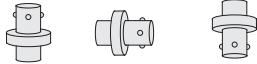
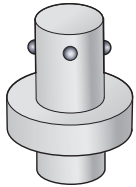

Active locking mechanism

For storage at all angles: vertical upwards and downwards or horizontal.

Coupling size	Ordering code	Pull action force, N	Pull action force, lbs	
C4	C4-PL-01	55	12.36	Central passive locking mechanism. Spring loaded clamping. Fits directly into all cassettes type 4000.
C5	C5-PL-01	120	26.98	
C6	C6-PL-01	150	33.72	
C8	C8-PL-01	240	53.95	
Coupling size	Ordering code	Rec. max. tool weight, kg	Rec. max. tool weight, lbs	
C4	C4-AL-01	40	88	Active locking mechanism – mechanical push action. Fits directly into all cassettes type 5000/6000.
C5	C5-AL-01	60	132	
C6	C6-AL-01	75	165	
C8	C8-AL-01	110	243	
C10	C10-AL-01	150	330.7	

Pre-measuring fixture for Coromant Capto® cutting units

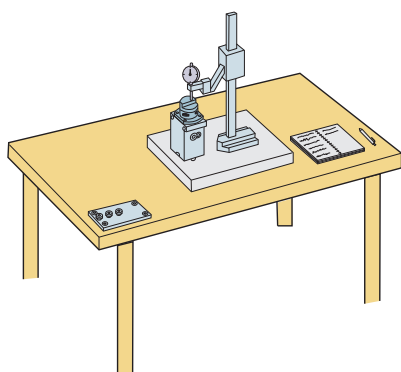

The precision of the Coromant Capto coupling ensures excellent repeatability when changing the same tool unit. This accuracy can be utilized in many ways, for example, in manual changing, the cutting edge indexing takes place outside the machine, where the edge positions can be checked in two co-ordinates on Sandvik's new pre-measuring fixture.

When the pre-measured unit is returned to the clamping unit in the turret, the edge deviation is compensated for through the machine control offset.

The fixture can be used with any dial indicator and preferably, a surface plate, but Sandvik recommend an indicator with a zero-set switch and a contact stylus.

Basic package

You may already have the required measuring equipment in your shop – all you need is the measuring kit:

- Pre-measuring unit
- Holding plate (anchor for tightening)
- Master

Pre-measuring unit

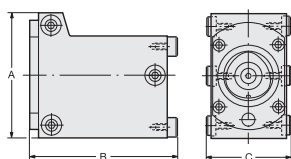

Coupling size	Ordering code	Dimensions, mm (inch)		
		A	B	C
C3	C3-PMU-01M	65 (2.56)	85 (3.35)	44 (1.79)
C4	C4-PMU-01M	77 (3.03)	94 (3.70)	54 (2.13)
C5	C5-PMU-01M	94 (3.70)	130 (5.12)	70 (2.76)
C6	C6-PMU-01	114 (4.40)	135 (5.31)	90 (3.54)
C8	C8-PMU-01	133 (5.24)	150 (5.91)	106 (4.17)

Holding plate

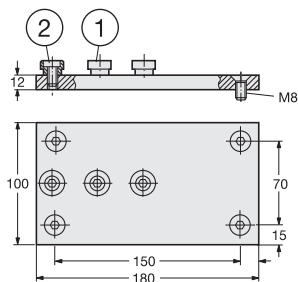

Coupling size	Ordering code	Spare parts	
		1	2
C3 – C8	C-HP-01	Stud	Screw
		5638 060-01	3212 020-409

Master setting gauges

B

Checking position for grippers Spindle orientation

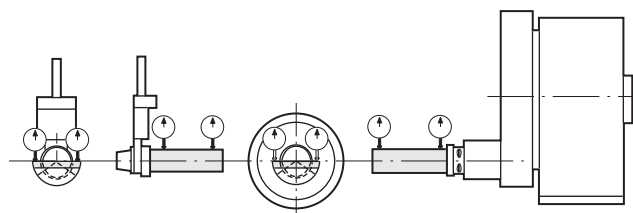

The Coromant Capto system guarantees exceptional, repeatable accuracy but this is of little use unless the various other components in the total machining process are correctly and accurately positioned. Coromant offers a range of axial and centre height master setting gauges for the various coupling sizes which are strongly recommended for setting important parameters such as:

C

Tool post centre line

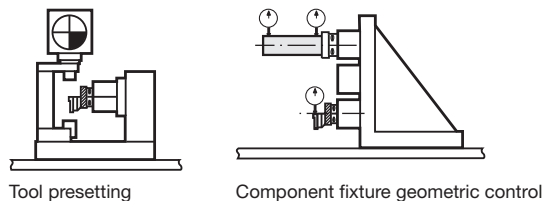

- The centre line of the tool post
- Spindle orientation
- The position of the tool for grippers
- Tool centre height and cutting edge position (f_1 and l_1 dimensions). Gauges can be used in a pre-measuring fixture
- Component fixtures

Axial gauge

G

Master setting gauges MAS-11

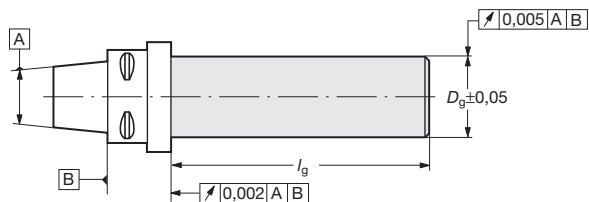

Coupling size	Ordering code	Dimensions, mm (inch)	
		D_g	l_g
C3	C3-MAS-11	25 (.98)	160 (6.30)
C4	C4-MAS-11	25 (.98)	160 (6.30)
C5	C5-MAS-11	32 (1.26)	210 (8.27)
C6	C6-MAS-11	40 (1.57)	315 (12.40)
C8	C8-MAS-11	40 (1.57)	315 (12.40)
C10	C10-MAS-11	60 (2.362)	420 (16.535)

Centre height gauge

H

Master setting gauges MAS-01

(Polygon) Gripper groove

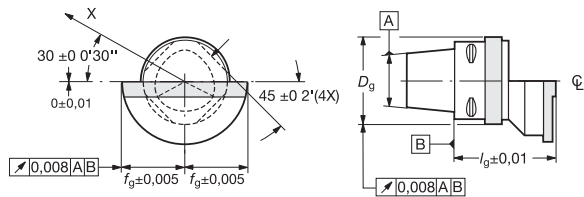

Coupling size	Ordering code	Dimensions, mm (inch)		
		f_g	l_g	D_g
C3	C3-MAS-01	22 (.87)	40 (1.57)	34 (1.34)
C4	C4-MAS-01	27 (1.06)	50 (1.97)	42 (1.65)
C5	C5-MAS-01	35 (1.38)	60 (2.36)	52 (2.05)
C6	C6-MAS-01	45 (1.77)	65 (2.56)	65 (2.56)
C8	C8-MAS-01	55 (2.17)	80 (3.15)	82 (3.23)
C10	C10-MAS-01	65 (2.559)	100 (3.937)	102 (4.016)

Alignment tool

I

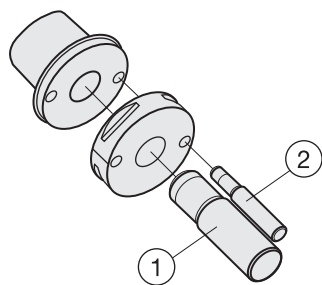

This tool is used to check the Automatic Tool Change positioning tolerance between the gripper arm and magazine and the clamping unit/spindle. If the tolerance is not achieved the result can be abnormal wear on cutting tool or Coromant Capto interface, wrong clamping, dropped tools, personal injuries etc. Instructions and tolerances are available in the box together with the tool.

Coupling size	Ordering code	Spare parts	
		1 Gauge pin	2 Gauge pin
C4	C4-AMT-01	5552 069-03	5552 069-01
C5	C5-AMT-01	5552 069-04	5552 069-01
C6	C6-AMT-01	5552 069-05	5552 069-02
C8	C8-AMT-01	5552 069-05	5552 069-02
C10	C10-AMT-01	5552 069-09	5552 069-08

J

Manually operated clamping units

Type 2085

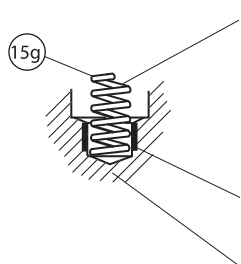
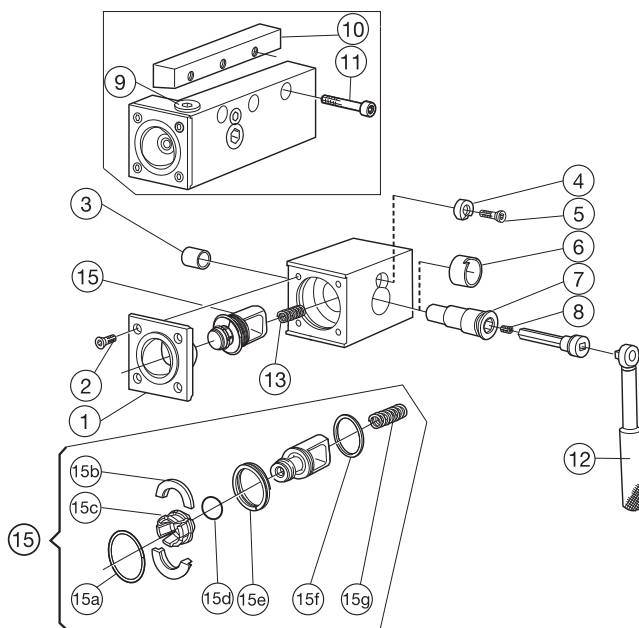

The spring, item 15g, should be used only when mounting draw bar set in old design clamping units, where the spring must be placed inside the plain bearing as shown on the picture.

Plain bearing

Draw bar hole, old design

	1	2	3	4	5	6	7
Coupling size	Sleeve	Screw (4 x)	Plain bearing	Locking washer	Screw	Plain bearing	Cam shaft
C3	5252 015-01	416.1-834	3823 010-101	5541 030-01	416.1-834	5638 022-01	5333 025-01
C4	5252 015-02	5513 020-26	3823 010-122	5541 030-02	416.1-834	5638 022-02	5333 025-02
C5	5252 015-03	5513 020-14	3823 010-162	5541 030-03	5513 020-14	5638 022-03	5333 025-03
	8	9	10	10	11	11	
Coupling size	Screw	Plug	Wedge inch version	Wedge metric version	Screw inch version	Screw metric version	
C3	3214 010-355	3611 005-180	5431 100-03	5431 115-01	3212 010-362	3212 010-362	
C4	3214 010-355	3611 005-180	5431 100-01	5431 115-02	3212 010-363	3212 010-364	
C5	3214 010-355	3611 005-180	5431 100-02	5431 115-03	3212 010-415	3212 010-416	
	12	13	14		15		
Coupling size	Torque wrench ²⁾	Compression spring	Lock screw inch	Rest button ¹⁾ inch version	Draw bar set		
C3	BT-TK-02	5561 001-71	3214 010-360	-	5461 100-101		
C4	C-TK-01	5561 001-41	3214 010-360	5511 052-01	5461 100-111		
C5	C-TK-01	5561 001-41	3214 010-360	-	5461 100-121		
	Draw bar set parts						
	15a	15b	15c	15d	15e	15f	15g
Coupling size	Spiral retaining ring	Holder set (set of 2)	Segment (set of 6)	O-ring	Flat wire spring	O-ring	Compression spring
C3	5545 039-01	5546 001-16	5549 120-08	5641 005-01	5561 015-02	5641 005-15	5561 001-81
C4	5545 039-03	5546 001-20	5549 120-06	5641 005-05	5561 015-03	5641 005-19	5561 001-82
C5	5545 039-02	5546 001-17	5549 120-07	5641 005-06	5561 015-04	5641 005-16	5561 001-83

¹⁾ Not shown on picture.

²⁾ Accessories, must be ordered separately

Manually operated clamping units

Type 2000

B

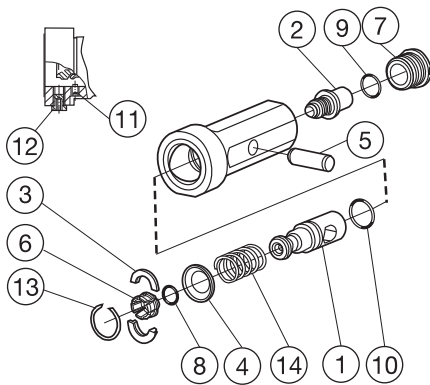

C

	1	2	3	4	5	6	7	8
Size	Drawbar	Clamping screw	Holder set (set of 2)	Ring	Support pin	Segment (set of 6)	Thread ring	O-ring
C3	5461 105-01	5519 105-01	5546 002-01	5541 028-01	5552 032-01	5549 120-08	5512 091-03	5641 005-01
C4	5461 105-02	5519 105-02	5546 002-02	5541 028-02	5552 032-02	5549 120-06	5512 091-01	5641 005-05
C5	5461 105-03	5519 105-03	5546 002-03	5541 028-03	5552 032-03	5549 120-07	5512 091-02	5641 005-06
	9	10	11	12	13	14		
Size	O-ring	O-ring	Screw	Blind plug	Circlip width	Spring	Key for clamping screw (mm)	
C3	3671 010-118	3671 010-124	3214 020-204	3611 005-180	5545 042-01	5561 001-52	3021 013-080 (8.0)	
C4	3671 010-120	3671 010-126	3214 020-255	3611 005-180	3421 105-026	5561 001-53	5680 010-03 (10.0)	
C5	3671 010-124	3671 010-128	3214 020-255	3611 005-180	3421 105-032	5561 001-54	5680 010-04 (12.0)	

G

Type 3000

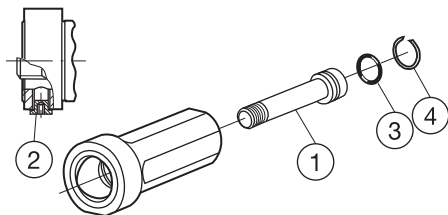

H

	1	2	3	4	
Size	Shank code	Clamping screw	Plug	O-ring	Retaining ring
C3		5512 096-01	3611 005-180	3671 010-020	5545 040-03
C4	-10020	5512 096-02	3611 005-180	3671 010-022	5545 040-05
C4	-12020	5512 096-04 ¹⁾	3611 005-180	3671 010-022	5545 040-05
C5		5512 096-03	3611 005-180	3671 010-024	5545 040-06
					Key for clamping screw (mm)
					3021 013-080 (8.0)
					5680 010-03 (10.0)
					5680 010-03 (10.0)
					5680 010-04 (12.0)

¹⁾ If you shorten the clamping unit C4-12020-50 use clamping screw 5512 096-02

I

J

Manually operated clamping units

Type 2080

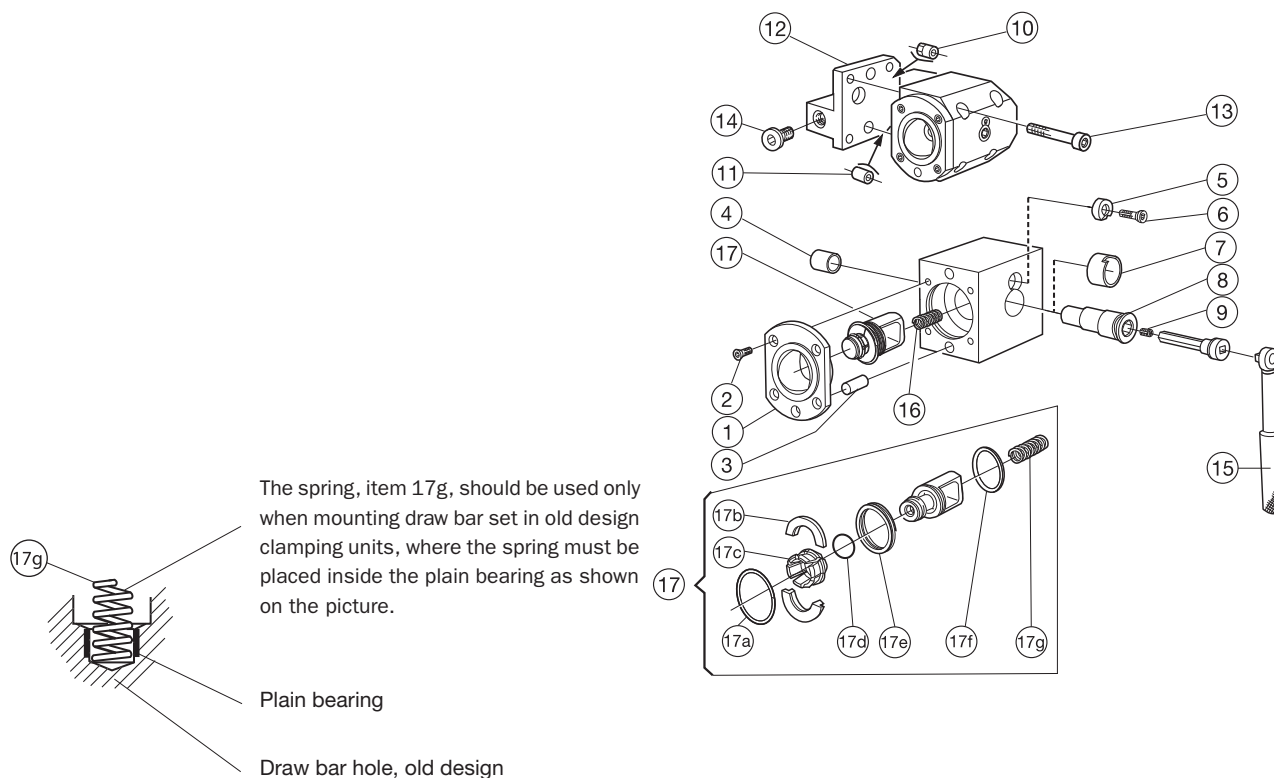

	1	2	3	4	5	6	7	8		
Size	Sleeve	Screw (4 x)	Parallel pin	Plain bearing	Locking washer	Screw	Plain bearing	Cam shaft		
C3	5252 010-01	416.1-834	3111 050-558	3823 010-101	5541 030-01	416.1-834	5638 022-01	5333 025-01		
C4	5252 010-02	5513 020-26	3111 050-610	3823 010-122	5541 030-02	416.1-834	5638 022-02	5333 025-02		
C5	5252 010-03	5513 020-14	3111 050-661	3823 010-162	5541 030-03	5513 020-14	5638 022-03	5333 025-03		
C6	5252 010-04	3213 010-410	3111 050-715	3823 010-183	5541 030-04	5513 020-14	5638 022-04	5333 025-04		
	9	10	11	12 Inch clamping unit						
Size	Screw	Locating pin	Dowel pin	(Right hand clamping unit)	Adaptor	(Left hand clamping unit)	Adaptor			
C3	3214 010-355	5552 063-05	5552 061-07	RC 2080-47074-12M	5253 105-09	LC 2080-47074-12M	5253 105-10			
C4	3214 010-355	5552 063-07	5552 061-09	RC 2080-59102-16A	5253 105-19	LC 2080-59102-16A	5253 105-20			
				RC 2080-66102-20A	5253 105-21	LC 2080-66102-20A	5253 105-22			
C5	3214 010-355	5552 063-06	5552 061-08	RC 2080-76118-20A	5253 105-15	LC 2080-76118-20A	5253 105-16			
C6	3214 010-355	-	-	RC 2080-85118-24A	5253 105-17	LC 2080-85118-24A	5253 105-18			
	12 Metric clamping unit			13				14	15	16
Size	(Right hand clamping unit)	Adaptor	(Left hand clamping unit)	Adaptor	Screw	Plug	Torque wrench ¹⁾	Compression spring		
C3	RC 2080-48090	5253 005-01	LC 2080-48090	5253 005-02	3212 010-363	3611 005-180	BT-TK-02	5561 001-71		
C4	RC 2080-59110A	5253 005-15	LC 2080-59110A	5253 005-16	3212 010-414	3611 005-140	C-TK-01	5561 001-41		
C5	RC 2080-77110A	5253 005-11	LC 2080-77110A	5253 005-12	3212 010-466	3611 005-140	C-TK-01	5561 001-41		
C6	RC 2080-93140	-	LC 2080-93140	-	-	3611 005-140	C-TK-01	5561 001-41		
	17 Draw bar set parts			17a	17b	17c	17d	17e	17f	17g
Size	Draw bar set	Spiral retaining ring	Holder set (set of 2)	Segment (set of 6)	O-ring	Flat wire spring	O-ring	Compression spring		
C3	5461 100-101	5545 039-01	5546 001-16	5549 120-08	5641 005-01	5561 015-02	5641 005-15	5561 001-81		
C4	5461 100-111	5545 039-03	5546 001-20	5549 120-06	5641 005-05	5561 015-03	5641 005-19	5561 001-82		
C5	5461 100-121	5545 039-02	5546 001-17	5549 120-07	5641 005-06	5561 015-04	5641 005-16	5561 001-83		
C6	5461 100-131	5545 039-04	5546 001-18	5549 120-04	5641 005-04	5561 015-05	5641 005-17	5561 001-83		

¹⁾ Accessories, must be ordered separately

Manually operated clamping units

Type 2090

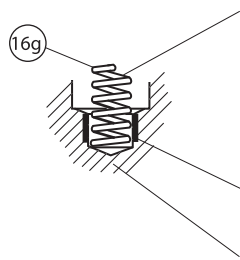
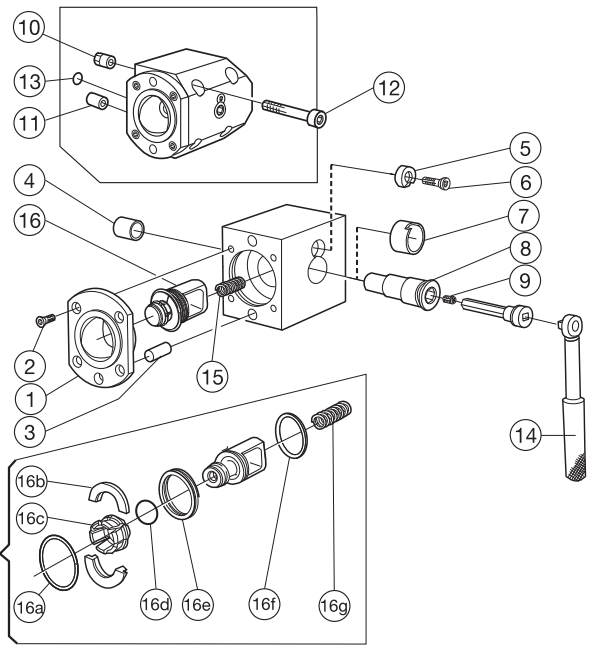

The spring, item 16g, should be used only when mounting draw bar set in old design clamping units, where the spring must be placed inside the plain bearing as shown on the picture.

Plain bearing

Draw bar hole, old design

	1	2	3	4	5	6	7
Size	Sleeve	Screw (4 x)	Parallel pin	Plain bearing	Locking washer	Screw	Plain bearing
C3	5252 010-01	416.1-834	3111 050-558	3823 010-101	5541 030-01	416.1-834	5638 022-01
C4	5252 010-02	5513 020-26	3111 050-610	3823 010-122	5541 030-02	416.1-834	5638 022-02
C5	5252 010-03	5513 020-14	3111 050-661	3823 010-162	5541 030-03	5513 020-14	5638 022-03
C6	5252 010-04	3213 010-410	3111 050-715	3823 010-183	5541 030-04	5513 020-14	5638 022-04
C8	5252 010-05	3213 010-462	3111 050-769	3823 010-225	5541 030-05	5513 020-14	5638 022-05

	8	9	10	11	12	13	14
Size	Cam shaft	Screw	Locating pin	Dowel pin	Screw	O-ring	Torque wrench ¹⁾
C3	5333 025-01	3214 010-355	5552 063-05	5552 061-07	3212 010-363	5641 001-22	BT-TK-02
C4	5333 025-02	3214 010-355	5552 063-07	5552 061-09	3212 010-414	3671 010-114	C-TK-01
C5	5333 025-03	3214 010-355	5552 063-06	5552 061-08	3212 010-466	3671 010-114	C-TK-01
C6	5333 025-04	3214 010-355	5552 063-03	5552 061-05	3212 010-469	3671 010-119	C-TK-01
C8	5333 025-05	3214 010-355	5552 063-04	5552 061-06	3212 010-521	3671 010-119	C-TK-02

	15	16
Size	Compression spring	Draw bar set
C3	5561 001-71	5461 100-101
C4	5561 001-41	5461 100-111
C5	5561 001-41	5461 100-121
C6	5561 001-41	5461 100-131
C8	5561 001-43	5461 100-141

	Draw bar set parts						
	16a	16b	16c	16d	16e	16f	16g
Size	Spiral retaining ring	Holder set (set of 2)	Segment (set of 6)	O-ring	Flat wire spring	O-ring	Compression spring
C3	5545 039-01	5546 001-16	5549 120-08	5641 005-01	5561 015-02	5641 005-15	5561 001-81
C4	5545 039-03	5546 001-20	5549 120-06	5641 005-05	5561 015-03	5641 005-19	5561 001-82
C5	5545 039-02	5546 001-17	5549 120-07	5641 005-06	5561 015-04	5641 005-16	5561 001-83
C6	5545 039-04	5546 001-18	5549 120-04	5641 005-04	5561 015-05	5641 005-17	5561 001-83
C8	5545 039-05	5546 001-19	5549 120-05	5641 005-07	5561 015-06	5641 005-18	5561 001-84

¹⁾ Accessories, must be ordered separately

Manually operated clamping units

Round shank

Type 2035/ 2045/ 2055/ 2065

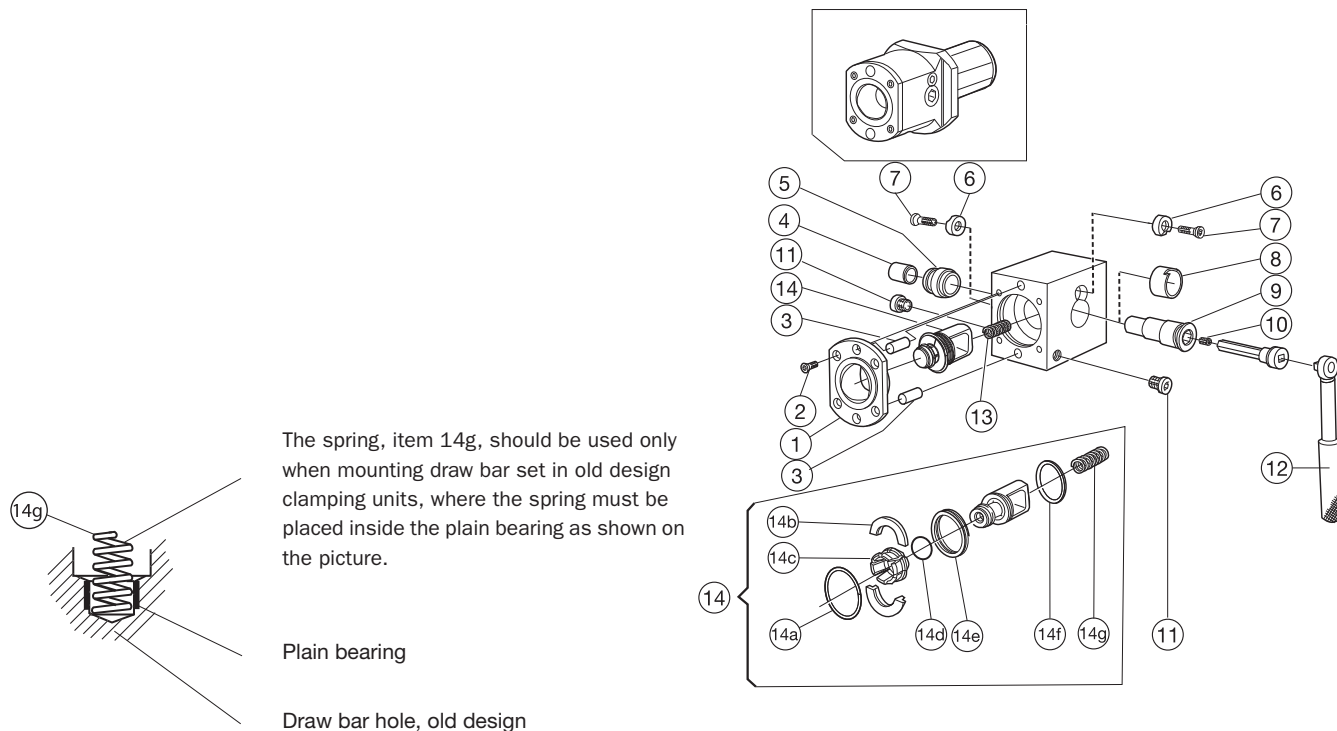

The spring, item 14g, should be used only when mounting draw bar set in old design clamping units, where the spring must be placed inside the plain bearing as shown in the picture.

Plain bearing

Draw bar hole, old design

	1	2	3	4	5	6	7
Size	Sleeve	Screw (4 x)	Parallel pin	Plain bearing	Bush	Locking washer	Screw
C3	5252 010-01	416.1-834	3111 050-558	3823 010-101	5638 024-01	5541 030-01	416.1-834
C4	5252 010-02	5513 020-26	3111 050-610	3823 010-122	5638 024-02	5541 030-02	416.1-834
C5	5252 010-03	5513 020-14	3111 050-661	3823 010-162	5638 024-03	5541 030-03	5513 020-14
C6	5252 010-04	3213 010-410	3111 050-715	3823 010-183	5638 024-04	5541 030-04	5513 020-14
	8	9	10	11	12	13	14
Size	Plain bearing	Cam shaft	Screw	Plug	Torque wrench ¹⁾	Compression spring	Draw bar set
C3	5638 022-01	5333 025-01	3214 010-355	3611 005-180	BT-TK-02	5561 001-71	5461 100-101
C4	5638 022-02	5333 025-02	3214 010-355	3611 005-180	C-TK-01	5561 001-41	5461 100-111
C5	5638 022-03	5333 025-03	3214 010-355	3611 005-180	C-TK-01	5561 001-41	5461 100-121
C6	5638 022-04	5333 025-04	3214 010-355	3611 005-140	C-TK-01	5561 001-41	5461 100-131
Draw bar set parts							
	14a	14b	14c	14d	14e	14f	14g
Size	Spiral retaining ring	Holder set (set of 2)	Segment (set of 6)	O-ring	Flat wire spring	O-ring	Compression spring
C3	5545 039-01	5546 001-16	5549 120-08	5641 005-01	5561 015-02	5641 005-15	5561 001-81
C4	5545 039-03	5546 001-20	5549 120-06	5641 005-05	5561 015-03	5641 005-19	5561 001-82
C5	5545 039-02	5546 001-17	5549 120-07	5641 005-06	5561 015-04	5641 005-16	5561 001-83
C6	5545 039-04	5546 001-18	5549 120-04	5641 005-04	5561 015-05	5641 005-17	5561 001-83

¹⁾ Accessories, must be ordered separately

Manually operated clamping units

VDI Angled design

DIN 69880

Type 2030/ 2040/ 2050/ 2060

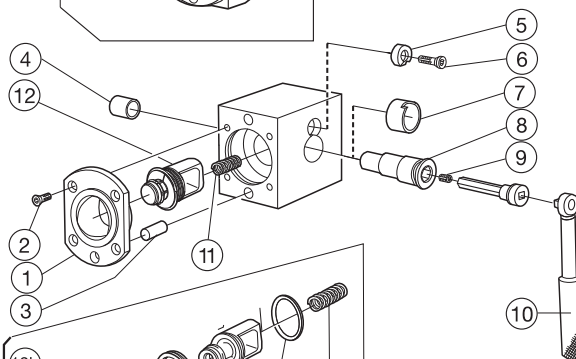
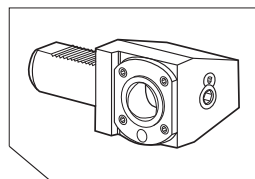

The spring, item 12g, should be used only when mounting draw bar set in old design clamping units, where the spring must be placed inside the plain bearing as shown on the picture.

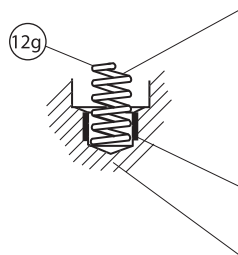

Plain bearing

Draw bar hole, old design

	1	2	3	4	5	6	
Size	Sleeve	Screw (4 x)	Parallel pin	Plain bearing	Locking washer	Screw	
C3	5252 010-01	416.1-834	3111 050-558	3823 010-101	5541 030-01	416.1-834	
C4	5252 010-02	5513 020-26	3111 050-610	3823 010-122	5541 030-02	416.1-834	
C5	5252 010-03	5513 020-14	3111 050-661	3823 010-162	5541 030-03	5513 020-14	
C6	5252 010-04	3213 010-410	3111 050-715	3823 010-183	5541 030-04	5513 020-14	
	7	8	9	10	11	12	
Size	Plain bearing	Cam shaft	Screw	Torque wrench ¹⁾	Compression spring	Draw bar set	
C3	5638 022-01	5333 025-01	3214 010-355	BT-TK-02	5561 001-71	5461 100-101	
C4	5638 022-02	5333 025-02	3214 010-355	C-TK-01	5561 001-41	5461 100-111	
C5	5638 022-03	5333 025-03	3214 010-355	C-TK-01	5561 001-41	5461 100-121	
C6	5638 022-04	5333 025-04	3214 010-355	C-TK-01	5561 001-41	5461 100-131	
	Draw bar set parts						
	12a	12b	12c	12d	12e	12f	12g
Size	Spiral retaining ring	Holder set (set of 2)	Segment (set of 6)	O-ring	Flat wire spring	O-ring	Compression spring
C3	5545 039-01	5546 001-16	5549 120-08	5641 005-01	5561 015-02	5641 005-15	5561 001-81
C4	5545 039-02	5546 001-20	5549 120-06	5641 005-05	5561 015-03	5641 005-19	5561 001-82
C5	5545 039-03	5546 001-17	5549 120-07	5641 005-06	5561 015-04	5641 005-16	5561 001-83
C6	5545 039-04	5546 001-18	5549 120-04	5641 005-04	5561 015-05	5641 005-17	5561 001-83

¹⁾ Accessories, must be ordered separately

Manually operated clamping units

VDI Straight design

DIN 69880

Type 2030/ 2040/ 2050/ 2060

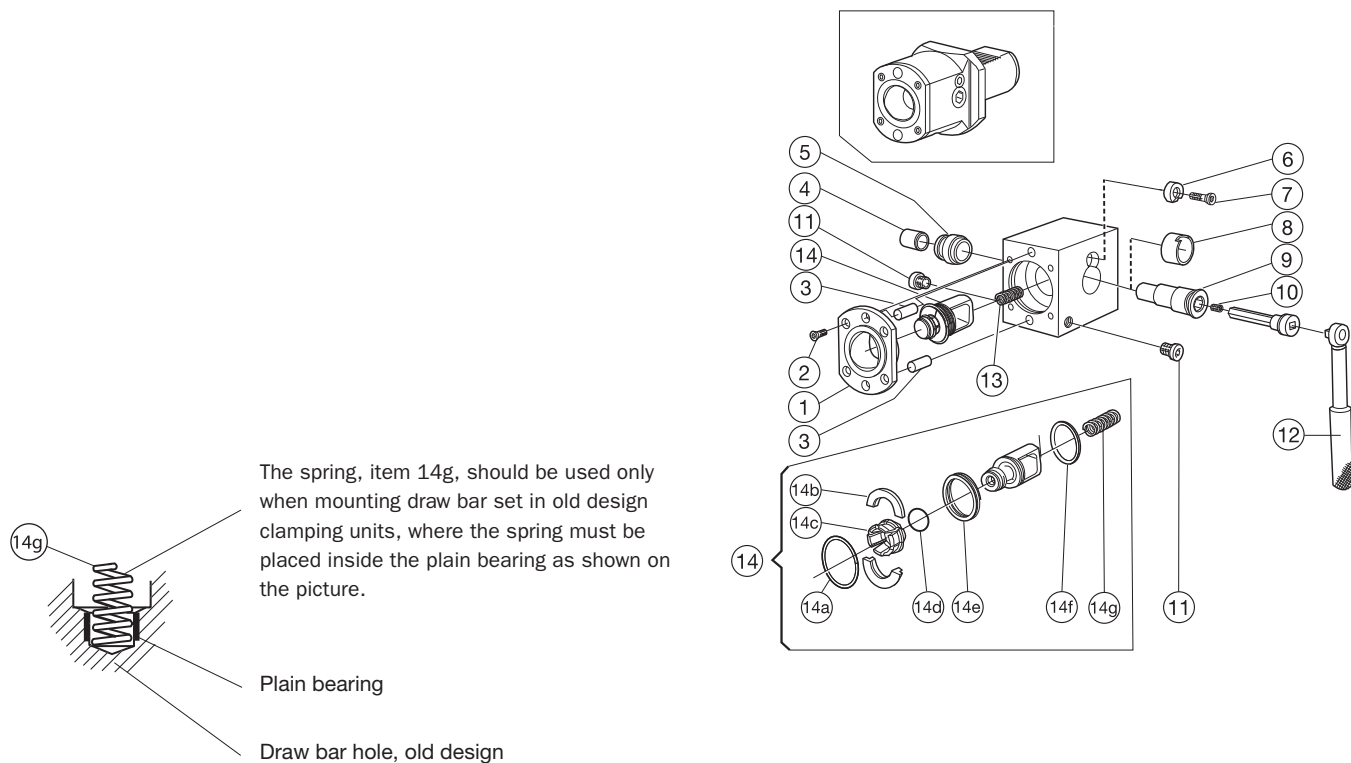

	1	2	3	4	5	6	7
Size	Sleeve	Screw (4 x)	Parallel pin	Plain bearing	Bush	Locking washer	Screw
C3	5252 010-01	416.1-834	3111 050-558	3823 010-101	5638 024-01	5541 030-01	416.1-834
C4	5252 010-02	5513 020-26	3111 050-610	3823 010-122	5638 024-02	5541 030-02	416.1-834
C5	5252 010-03	5513 020-14	3111 050-661	3823 010-162	5638 024-03	5541 030-03	5513 020-14
C6	5252 010-04	3213 010-410	3111 050-715	3823 010-183	5638 024-04	5541 030-04	5513 020-14
	8	9	10	11	12	13	14
Size	Plain bearing	Cam shaft	Screw	Plug	Torque wrench ¹⁾	Compression spring	Draw bar set
C3	5638 022-01	5333 025-01	3214 010-355	3611 005-180	BT-TK-02	5561 001-71	5461 100-101
C4	5638 022-02	5333 025-02	3214 010-355	3611 005-180	C-TK-01	5561 001-41	5461 100-111
C5	5638 022-03	5333 025-03	3214 010-355	3611 005-180	C-TK-01	5561 001-41	5461 100-121
C6	5638 022-04	5333 025-04	3214 010-355	3611 005-140	C-TK-01	5561 001-41	5461 100-131
Draw bar set parts							
	14a	14b	14c	14d	14e	14f	14g
Size	Spiral retaining ring	Holder set (set of 2)	Segment (set of 6)	O-ring	Flat wire spring	O-ring	Compression spring
C3	5545 039-01	5546 001-16	5549 120-08	5641 005-01	5561 015-02	5641 005-15	5561 001-81
C4	5545 039-03	5546 001-20	5549 120-06	5641 005-05	5561 015-03	5641 005-19	5561 001-82
C5	5545 039-02	5546 001-17	5549 120-07	5641 005-06	5561 015-04	5641 005-16	5561 001-83
C6	5545 039-04	5546 001-18	5549 120-04	5641 005-04	5561 015-05	5641 005-17	5561 001-83

¹⁾ Accessories, must be ordered separately

Manually operated clamping units

B

CDI external
R/LCE80-028 082

CDI external
R/LCE80-028 082-2

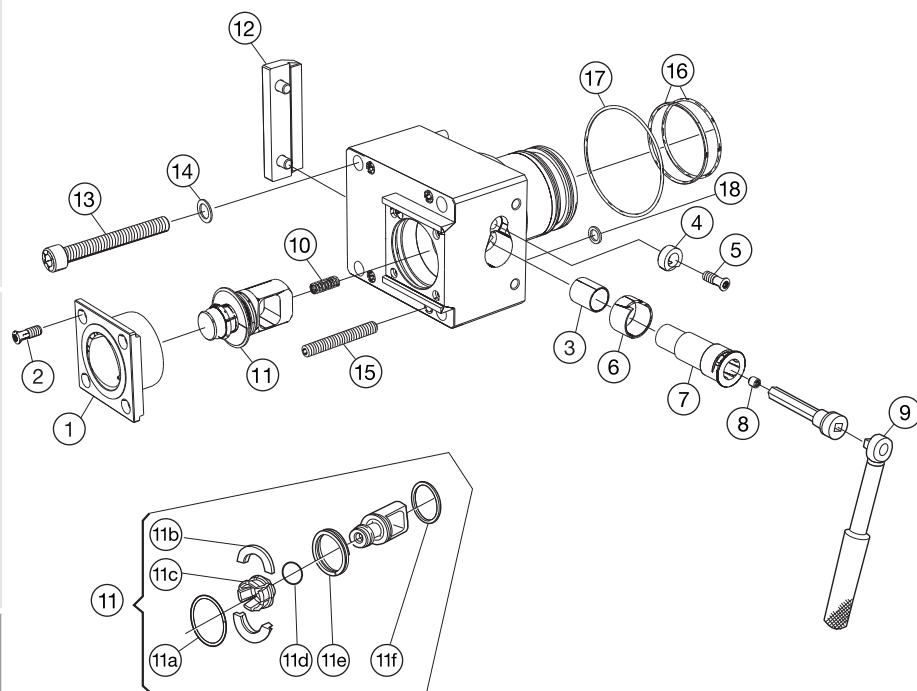

C

G

	1	2	3	4	5	6	7
Type	Sleeve	Screw (4 x)	Plain bearing	Locking washer	Screw	Plain bearing	Cam shaft
C5-R/LCE80-028082	5252 015-03	5513 020-14	3823 010-162	5541 030-03	5513 020-14	5638 022-03	5333 025-03
C5-R/LCE80-028082-2	5252 015-03	5513 020-14	3823 010-162	5541 030-03	5513 020-14	5638 022-03	5333 025-03
	8	9	10	11			
Type	Screw	Torque wrench ¹⁾	Compression spring	Draw bar set			
C5-R/LCE80-028082	3214 010-355	C-TK-01	5561 001-41	5461 100-121 (1x)			
C5-R/LCE80-028082-2	3214 010-355	C-TK-01	5561 001-41	5461 100-121 (2x)			
	Draw bar set parts	11a	11b	11c	11d	11e	11f
Type	Spiral retaining ring	Holder set (set of 2)	Segment (set of 6)	O-ring	Flat wire spring	O-ring	
C5-R/LCE80-028082	5545 039-02	5546 001-17	5549 120-07	5641 005-06	5561 015-04	5641 005-16	
C5-R/LCE80-028082-2	5545 039-02	5546 001-17	5549 120-07	5641 005-06	5561 015-04	5641 005-16	
	12	13	14	15			
Type	Adjustment plate	Cap screw (4x)	Locking washer (4x)	Set screw (4x)			
C5-R/LCE80-028082	5336 002-02	3212 010-471	5541 041-02	3214 010-418			
C5-R/LCE80-028082-2	5336 002-01	3212 010-471	5541 041-02	3214 010-418			
	16	17	18				
Type	O-ring	O-ring	Kantseal (2x)				
C5-R/LCE80-028082	5641 005-104	5641 001-79	5641 070-04				
C5-R/LCE80-028082-2	5641 005-104	5641 001-79	5641 070-04				

H

I

J

Manually operated clamping units

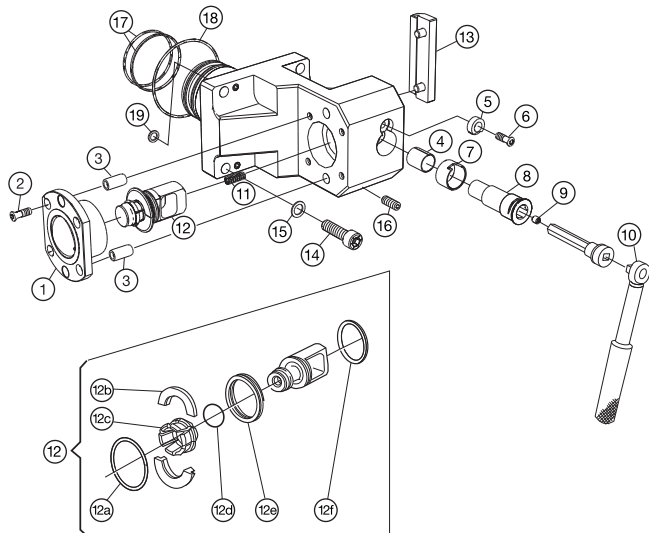
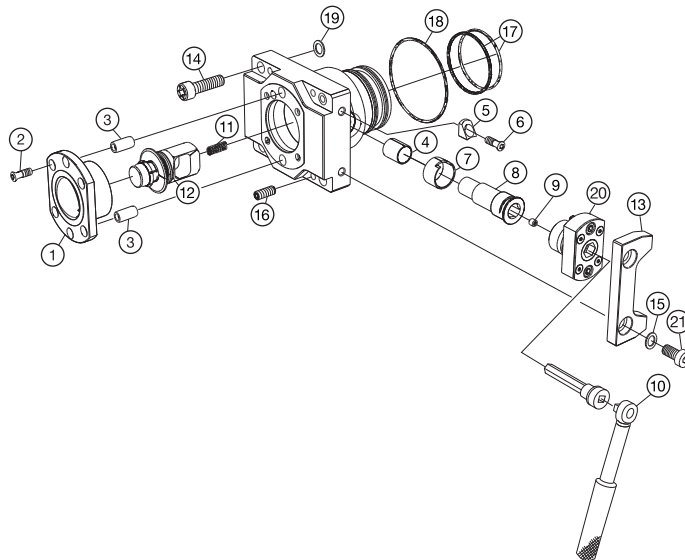
CDI internal
R/LCI80-000110CDI external
R/LCE040000

	1	2	3	4	5	6
Type	Sleeve	Screw (4 x)	Parallel pin	Plain bearing	Locking washer	Screw
C5-R/LCI80-000110	5252 010-03	5513 020-14	3111 050-661	3823 010-162	5541 030-03	5513 020-14
C5-R/LCI80-000120	5252 010-03	5513 020-14	3111 050-661	3823 010-162	5541 030-03	5513 020-14
C5-R/LCE80-040000	5252 010-03	5513 020-14	3111 050-661	3823 010-162	5541 030-10	5513 020-14
C5-R/LCI80-096110-2	5252 010-03	5513 020-14	3111 050-661	3823 010-162	5541 030-03	5513 020-14
	7	8	9	10	11	12
Type	Plain bearing	Cam shaft	Screw	Torque wrench ¹⁾	Compression spring	Draw bar set
C5-R/LCI80-000110	5638 022-03	5333 025-03	3214 010-355	C-TK-01	5561 001-41	5461 100-121
C5-R/LCI80-000120	5638 022-03	5333 025-03	3214 010-355	C-TK-01	5561 001-41	5461 100-121
C5-R/LCE80-040000	5638 022-03	5333 025-03	3214 010-355	C-TK-01	5561 001-41	5461 100-121
C5-R/LCI80-096110-2	5638 022-03	5333 025-03	3214 010-355	C-TK-01	5561 001-41	5461 100-121
	Draw bar set parts					
	12a	12b	12c	12d	12e	12f
Type	Spiral retaining ring	Holder set (set of 2)	Segment (set of 6)	O-ring	Flat wire spring	O-ring
C5-R/LCI80-000110	5545 039-02	5546 001-17	5549 120-07	5641 005-06	5561 015-04	5641 005-16
C5-R/LCI80-000120	5545 039-02	5546 001-17	5549 120-07	5641 005-06	5561 015-04	5641 005-16
C5-R/LCE80-040000	5545 039-02	5546 001-17	5549 120-07	5641 005-06	5561 015-04	5641 005-16
C5-R/LCI80-096110-2	5545 039-02	5546 001-17	5549 120-07	5641 005-06	5561 015-04	5641 005-16
	13	14	15	16		
Type	Adjustment plate	Cap screw (4x)	Locking washer	Set screw (4x)		
C5-R/LCI80-000110	5336 002-02	3212 010-02	5541 041-02 (4x)	3214 010-410		
C5-R/LCI80-000120	5336 002-02	3212 010-02	5541 041-02 (4x)	3214 010-410		
C5-R/LCE80-040000	5336 001-01	3212 010-463	5541 041-01 (2x)	3214 010-410		
C5-R/LCI80-096110-2	5336 002-02	3212 010-02	5541 041-02 (4x)	3214 010-410		
	17	18	19	20	21	
Type	O-ring	O-ring	Kantseal (2x)	Adaptor	Screw (2x)	
C5-R/LCI80-000110	5641 005-104	5641 001-79	5641 070-04	-	-	
C5-R/LCI80-000120	5641 005-104	5641 001-79	5641 070-04	-	-	
C5-R/LCE80-040000	5641 005-104	5641 001-79	5641 070-04	5253 006-03	5512 060-24	
C5-R/LCI80-096110-2	5641 005-104	5641 001-79	5641 070-04	-	-	

A

Holders for CDI 80

Holder for parting blade APB-TNE-CDI80-25

B

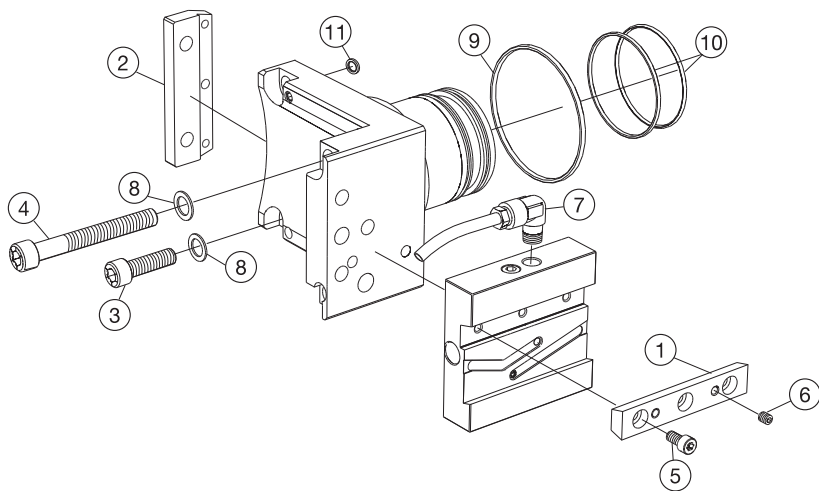

C

	1	2	3	4	5	6
Type	Wedge	Adjustment plate	Screw	Screw	Screw	Set screw
APB-TNE-CDI80-25	5431 115-04	5336 002-02	3212 010-462	5512 060-21	3212 010-308	3214 010-305
	7	8	9	10	11	
Type	Coolant tube set	Locking washer	O-ring (1 x)	O-ring (2 x)	Kantseal	
APB-TNE-CDI80-25	5692 021-01	5541 041-02	5641 001-79	5641 005-104	5641 070-04	

G

H

I

J

Holders for CDI 80

Holder for boring bar
ABB-TNE-CDI80-40-000120

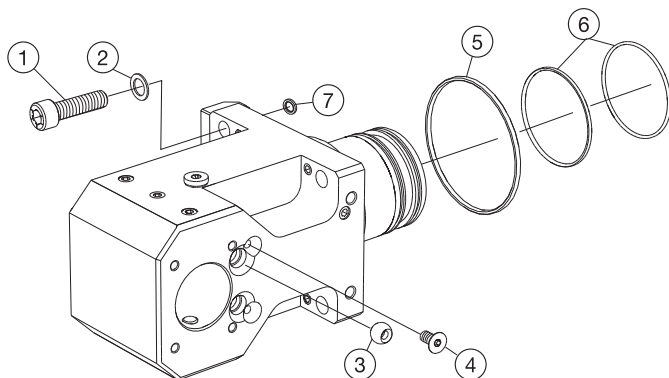

	1	2	3	4	5	6
Type	Screw	Locking washer	Coolant nozzle	Screw	O-ring (1 x)	O-ring (2 x)
ABB-TNE-CDI80-40-000120	3212 010-463	5541 041-02	5691 030-03	3213 010-358	5641 001-79	5641 005-104
	7					
Type	Kantseal					
ABB-TNE-CDI80-40-000120	5641 070-04					

Holders for CDI 80

Adaptor for shank holder ASH-TNE-CDI80-25

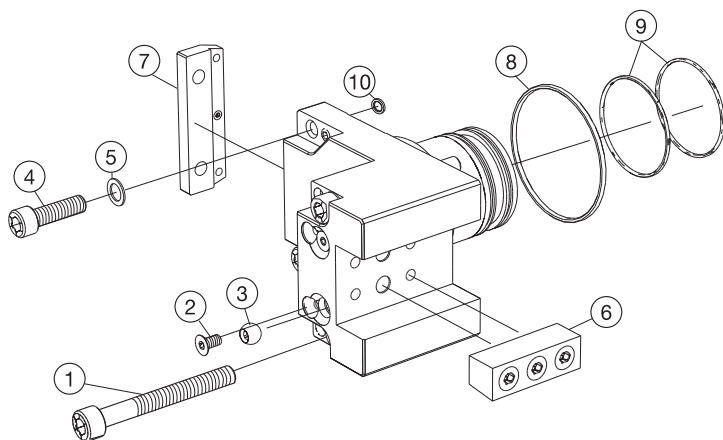

B

C

G

	1	2	3	4	5	6
Type	Screw	Screw	Coolant nozzle	Screw	Locking washer	Wedge set
ASH-TNE-CDI80-25	3212 010-472	3212 010-358	5691 030-03	3212 010-463	5541 041-02	5431 130-01
	7	8	9	10		
Type	Adjustment plate	O-ring (1 x)	O-ring (2 x)	Kantseal		
ASH-TNE-CDI80-25	5336 002-02	5641 001-79	5641 005-104	5641 070-04		

H

I

J

Driven tool holders

CDI80

External

Cx-DNE80-044000-I

Cx-DNE80-044000-E

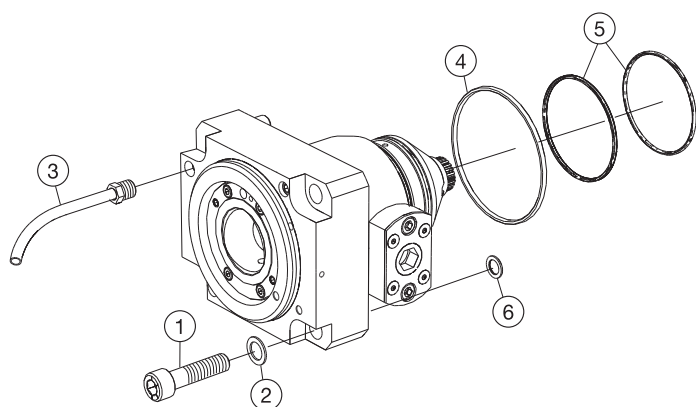

	1	2	3	4	5	6
Type	Screw	Locking washer	Coolant tube set	O-ring (1 x)	O-ring (2 x)	Kantseal
Cx-DNE80-044000-I	3212 010-464	5541 041-02	5692 023-02	5641 001-79	5641 005-104	5641 070-04
Cx-DNE80-044000-E	3212 010-464	5541 041-02	5692 023-02	5641 001-79	5641 005-104	5641 070-04

A

Driven tool holders

CDI80

Internal

Cx-DNI80-040110-I

Cx-DNI80-040110-E

B

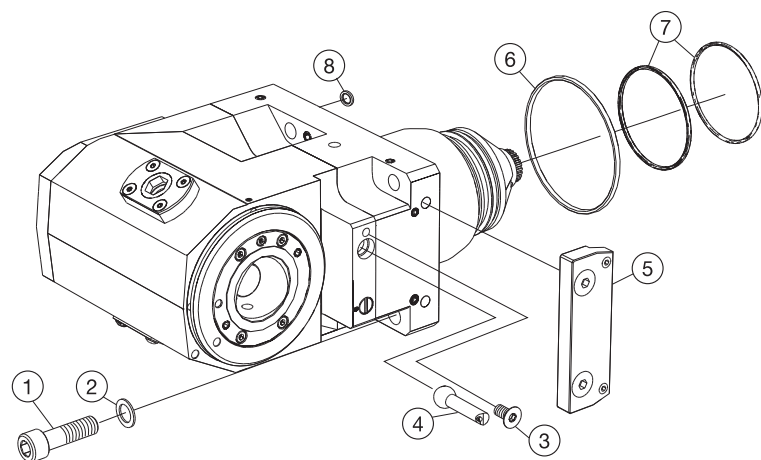

C

G

	1	2	3	4	5
Type	Screw	Locking washer	Screw	Coolant nozzle	Adjustment plate
C5-DNI80-040110-I	3212 010-463	5641 041-02	3213 010-358	5691 036-01	5336 002-02
C5-DNI80-040110-E	3212 010-463	5641 041-02	3213 010-358	5691 036-01	5336 002-02

H

	6	7	8
Type	O-ring (1 x)	O-ring (2 x)	Kantseal
C5-DNI80-040110-I	5641 001-79	5641 005-104	5641 007-04
C5-DNI80-040110-E	5641 001-79	5641 005-104	5641 007-04

I

J

Manually operated clamping units

VDI

DIN 69881

Cx-R/LC115

Cx-R/LC140

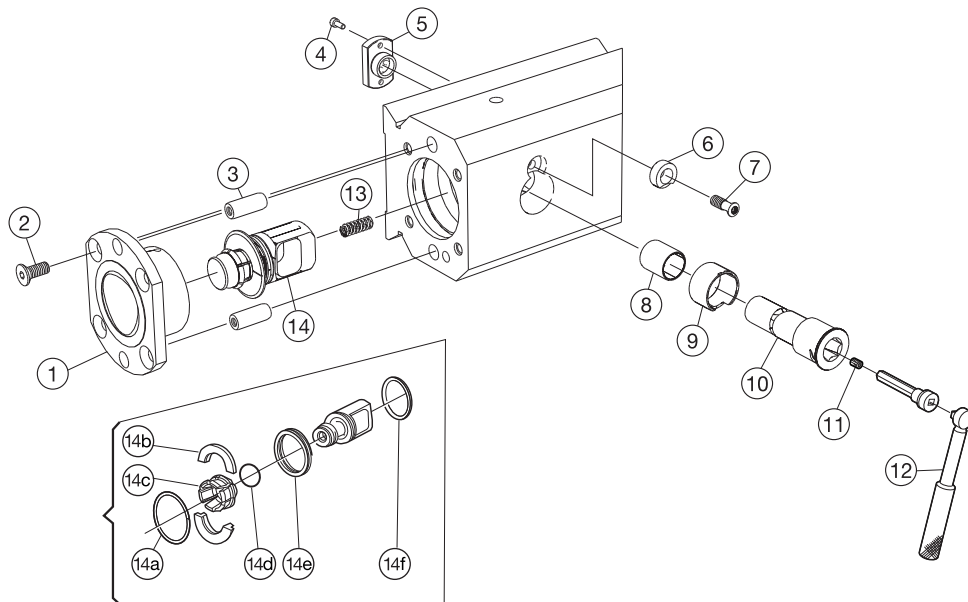

	1	2	3	4	5	6
Type	Sleeve	Screw	Parallell pin	Screw	Location bung	Locking washer
C6-R/LC115-130L	5252 010-04	3213 010-410	3111 050-715	3212 010-257	5336 003-01	5541 030-04
C6-R/LC140-165L						
C6-R/LC140-205L						
C8-R/LC140-165L	5252 010-05	3213 010-462	3111 050-769	3212 010-257	5336 003-01	5541 030-05
C8-R/LC140-205L						
	7	8	9	10	11	12
Type	Screw	Plain bearing	Plain bearing	Cam shaft	Screw	Torque wrench
C6-R/LC115-130L	5513 020-14	3823 010-183	5638 022-04	5333 025-04	3214 010-355	C-TK-01
C6-R/LC140-165L						
C6-R/LC140-205L						
C8-R/LC140-165L	5513 020-14	3823 010-225	5638 022-05	5333 025-05	3214 010-355	C-TK-02
C8-R/LC140-205L						
	13	14				
Type	Compression spring	Draw bar set				
C6-R/LC115-130L	5561 001-41	5461 100-131				
C6-R/LC140-165L						
C6-R/LC140-205L						
C8-R/LC140-165L	5561 001-43	5461 100-141				
C8-R/LC140-205L						
	14a	14b	14c	14d	14e	14f
Type	Spiral retaining ring	Holder set (set of 2)	Segment (set of 6)	O-ring	Flat wire spring	O-ring
C6-R/LC115-130L	5545 039-04	5546 001-18	5549 120-4	5641 005-17	5561 015-05	5641 005-17
C6-R/LC140-165L						
C6-R/LC140-205L						
C8-R/LC140-165L	5545 039-05	5546 001-19	5549 120-5	5641 005-18	5561 015-06	5641 005-18
C8-R/LC140-205L						

Hydraulically operated clamping units

Type 5010

Straight design

B

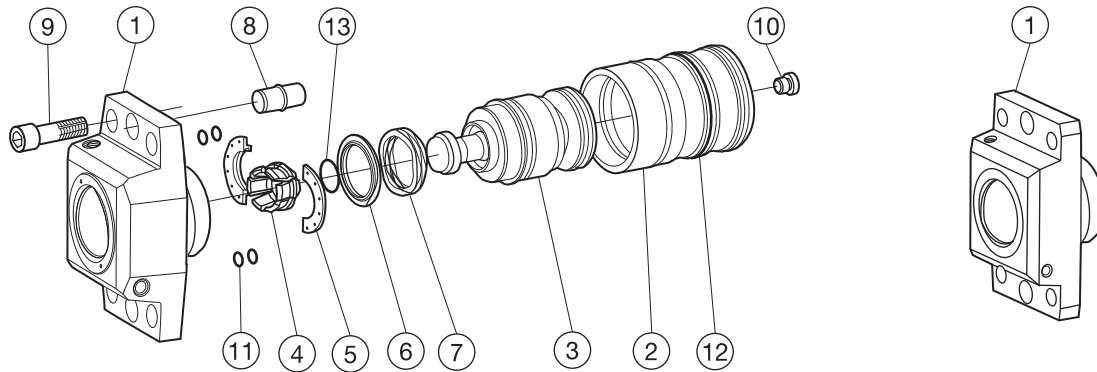

C

NC5010

NC5000

Clamping unit NC5010

To be able to maintain the min. bore, the new clamping unit has a modified front and hole pattern, which means that NC5010 and NC5000 not are interchangeable.

Spare parts for NC5000 are the same as for NC5010 except for part 1, the front.

G

Straight design

	1 NC5010	2 NC5010/NC5000	3	4	5	6	7
Size	Front	Barrel	Clamping mechanism	Segment (set of 6)	Holder set (set of 2)	Ring	Flat wire spring
C4	5252 033-11	5257 001-01	5651 065-01	5549 120-06	5546 001-14	5541 024-01	5561 012-01
C5	5252 033-12	5257 001-02	5651 065-02	5549 120-07	5546 001-11	5541 024-02	5561 012-02
C6	5252 033-13	5257 001-03	5651 065-03	5549 120-04	5546 001-09	5541 024-03	5561 012-03
C8	5252 033-14	5257 001-04	5651 065-04	5549 120-05	5546 001-10	5541 024-04	5561 012-04
C8X	5252 033-15	5257 001-04	5651 065-04	5549 120-05	5546 001-10	5541 024-04	5561 012-04
C10	5252 033-16	5257 001-05	5651 065-05	5549 120-09	5546 001-13	5541 025-04	5561 012-04
	8	9	10	11	12	13	1
							NC5000
Size	Dowel	Screw (4 x)	Plug	O-ring (6 x)	O-ring (3 x)	O-ring	Front
C4	5552 055-02	3212 010-411	3611 007-180	3671 010-112	5641 001-21	5641 005-05	5252 030-11
C5	5552 055-03	3212 010-462	3611 007-180	3671 010-112	3671 010-134	5641 005-06	5252 030-12
C6	5552 055-04	3212 010-514	3611 007-180	3671 010-114	3671 010-137	5641 005-04	5252 030-13
C8	5552 055-05	3212 010-514	3611 007-180	3671 010-116	3671 010-141	5641 005-04	5252 030-14
C8X	5552 055-05	3212 010-514	3611 007-180	3671 010-116	3671 010-141	5641 005-04	
C10	5552 055-07	3212 010-616	3611 007-180	3671 010-019	5641 010-141	5641 005-95	

H

NC5000 units can be ordered as specials. Contact your local Sandvik Coromant representative

J

Hydraulically operated clamping units with probe contact

Jetbreak™

Type 5210

Straight design

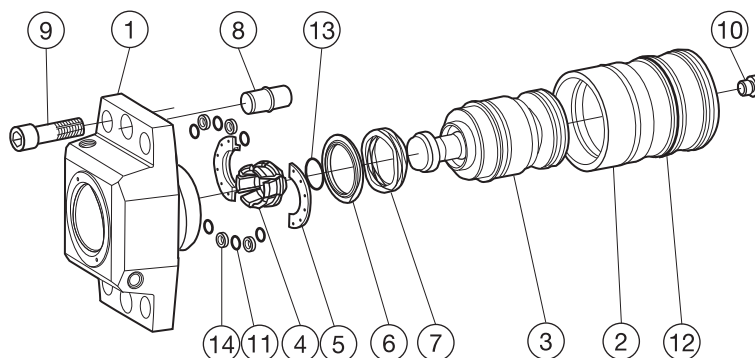

Straight design

	1	2	3	4	5	6	7
Size	Front	Barrel	Clamping mechanism	Segment (set of 6)	Holder set (set of 2)	Ring	Flat wire spring
C5	5252 034-12	5257 001-02	5651 065-02	5549 120-07	5546 001-11	5541 024-02	5561 012-02
C6	5252 034-13	5257 001-03	5651 065-03	5549 120-04	5546 001-09	5541 024-03	5561 012-03
C8	5252 034-14	5257 001-04	5651 065-04	5549 120-05	5546 001-10	5541 024-04	5561 012-04
	8	9	10	11	12	13	14
Size	Dowel	Screw (4 x)	Plug	O-ring (6 x)	O-ring (3 x)	O-ring	Sealing (4 x)
C5	5552 055-03	3212 010-462	3611 007-180	3671 010-112	3671 010-134	5641 005-06	5641 070-01
C6	5552 055-04	3212 010-514	3611 007-180	3671 010-114	3671 010-137	5641 005-04	5641 070-04
C8	5552 055-05	3212 010-514	3611 007-180	3671 010-116	3671 010-141	5641 005-04	5641 070-03

Hydraulically operated clamping units with probe contact

Type 5110

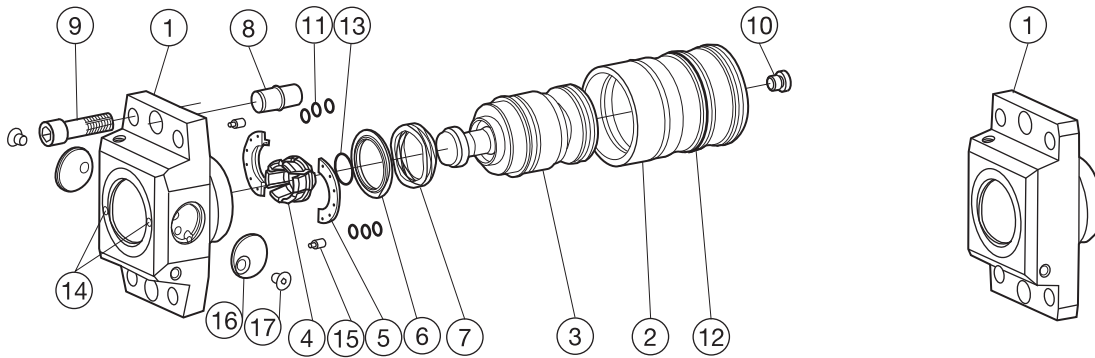

NC5110

NC5100

Clamping unit NC5110

To be able to maintain the min. bore, the new clamping unit has a modified front and hole pattern, which means that NC5110 and NC5100 not are interchangeable.

Spare parts for NC5100 are the same as for NC5110 except for part 1, the front.

	1 NC5110	2 NC5110/NC5100	3 Clamping mechanism	4 Segment (set of 6)	5 Holder set (set of 2)	6 Ring	7 Flat wire spring
Size	Front	Barrel					
C4	5252 035-11	5257 001-01	5651 065-01	5549 120-06	5546 001-14	5541 024-01	5561 012-01
C5	5252 035-12	5257 001-02	5651 065-02	5549 120-07	5546 001-11	5541 024-02	5561 012-02
C6	5252 035-13	5257 001-03	5651 065-03	5549 120-04	5546 001-09	5541 024-03	5561 012-03
C8	5252 035-14	5257 001-04	5651 065-04	5549 120-05	5546 001-10	5541 024-04	5561 012-04
	8	9	10	11	12	13	14
Size	Dowel	Screw (4 x)	Plug	O-ring (6 x)	O-ring (3 x)	O-ring	Static contact
C4	5252 055-02	3212 010-411	3611 007-180	3671 010-112	5641 001-21	5641 005-05	BT-CS-01
C5	5252 055-03	3212 010-462	3611 007-180	3671 010-112	3671 010-134	5641 005-06	BT-CS-01
C6	5252 055-04	3212 010-514	3611 007-180	3671 010-114	3671 010-137	5641 005-04	BT-CS-01
C8	5252 055-05	3212 010-514	3611 007-180	3671 010-116	3671 010-141	5641 005-04	BT-CS-01
	15	16	17	1 NC5100			
Size	Static contact	Cover	Screw	Front			
C4	BT-SCU-01	5643 021-01	3213 011-255	5252 031-11			
C5	BT-SCU-01	-	-	5252 031-12			
C6	BT-SCU-01	-	-	5252 031-13			
C8	BT-SCU-01	-	-	5252 031-14			

Adaptor for solid boring bars

Cx-131

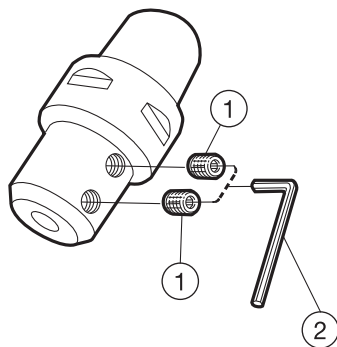

	1	2	
	Screw	Key inch/mm	
Metric	Screw codes		
C3-131-00035-10	5514 020-04	174.1-864	3.0
C3-131-00040-12	5514 020-04	174.1-864	3.0
C4-131-00040-10	5514 020-04	174.1-864	3.0
C4-131-00045-12	5514 020-04	174.1-864	3.0
C4-131-00050-16	5514 020-02	3021 010-040	4.0
C5-131-00045-10	5514 020-04	174.1-864	3.0
C5-131-00045-12	5514 020-04	174.1-864	3.0
C5-131-00055-16	5514 020-02	3021 010-040	4.0
Inch	Screw specification ¹⁾		
C3-131-00050-250	10-32UNF x .500	265.2-818	3/32
C3-131-00050-500	1/4-2832UNF x .500	174.1-871	1/8
C3-131-00050-625	3/8-2432UNF x .500	174.1-872	3/16
C4-131-00050-250	10-32UNF x .500	265.2-818	3/32
C4-131-00050-375	1/4-28UNF x .500	174.1-871	1/8
C4-131-00050-500	1/4-28UNF x .500	174.1-871	1/8
C4-131-00050-625	3/8-24UNF x .500	174.1-872	3/16
C4-131-00060-750	3/8-24UNF x .500	174.1-872	3/16
C4-131-00091-1000	M10-1.5 x 25	3021 010-050	5.0
C5-131-00060-375	1/4-28UNF x .500	174.1-871	1/8
C5-131-00060-500	1/4-28UNF x .500	174.1-871	1/8
C5-131-00060-625	3/8-24UNF x .500	174.1-872	3/16
C5-131-00060-750	3/8-24UNF x .500	174.1-872	3/16
C5-131-00070-1000	1/2-20UNF x .500	174.1-873	1/4
C5-131-00115-1500	M10-1.5 x 25	3021 010-050	5.0
C6-131-00065-375	1/4-28UNF x .500	174.1-871	1/8
C6-131-00065-500	1/4-28UNF x .500	174.1-871	1/8
C6-131-00065-625	3/8-24UNF x .500	174.1-872	3/16
C6-131-00065-750	3/8-24UNF x .500	174.1-872	3/16
C6-131-00075-1000	1/2-20UNF x .500	174.1-873	1/4
C6-131-00105-1500	M10-1.5 x 25	3021 010-050	5.0

¹⁾ Standard screws to be purchased from outside vendor.

Extension/reduction adaptors

Cx-391.01A/ Cx-391.01HD
Cx-391.02/ Cx-391.02HD

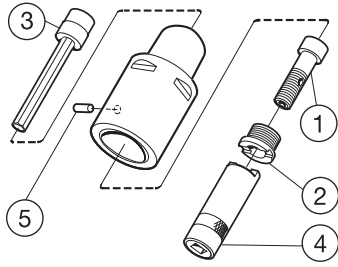

	1	2	3 ¹⁾	4 ¹⁾	5
	Centre screw	Retaining ring	Extension key (mm)	Key	Pin
C3-391.01-32 xxxA	5512 067-01	5512 091-04	5680 015-05 (8.0)	5680 065-13	3113 020-304
C4-391.01-40 xxxA	5512 067-02	5512 091-03	5680 015-05 (8.0)	5680 065-10	3113 020-355
C5-391.01-50 xxxA	5512 067-03	5512 091-01	5680 015-01 (10.0)	5680 065-11	3113 020-406
C6-391.01-63 xxxA	5512 067-04	5512 091-02	5680 015-02 (14.0)	5680 065-12	3113 020-457
C8-391.01-80 xxxA	5512 067-04	5512 091-02	5680 015-02 (14.0)	5680 065-12	3113 020-509
C8x-391.01-100 xxx	5512 067-04	5512 091-02	5680 015-02 (14.0)	5680 065-12	3113 020-509
C4-391.02-32 055A	5512 067-01	5512 091-04	5680 015-05 (8.0)	5680 065-13	3113 020-304
C4-391.02-32 070A	5512 067-01	5512 091-04	5680 015-05 (8.0)	5680 065-13	3113 020-304
C5-391.02-32 060A	5512 067-01	5512 091-04	5680 015-05 (8.0)	5680 065-13	3113 020-304
C5-391.02-40 065A	5512 067-02	5512 091-03	5680 015-05 (8.0)	5680 065-10	3113 020-355
C5-391.02-40 085A	5512 067-02	5512 091-03	5680 015-05 (8.0)	5680 065-10	3113 020-355
C6-391.02-32 070A	5512 067-01	5512 091-04	5680 015-05 (8.0)	5680 065-13	3113 020-304
C6-391.02-40 080A	5512 067-02	5512 091-03	5680 015-05 (8.0)	5680 065-10	3113 020-355
C6-391.02-50 080A	5512 067-03	5512 091-01	5680 015-01 (10.0)	5680 065-11	3113 020-406
C6-391.02-50 110A	5512 067-03	5512 091-01	5680 015-01 (10.0)	5680 065-11	3113 020-406
C8-391.02-32 060A	5512 067-01	5512 091-04	5680 015-05 (8.0)	5680 065-13	3113 020-304
C8-391.02-40 070A	5512 067-02	5512 091-03	5680 015-05 (8.0)	5680 065-10	3113 020-355
C8-391.02-50 080A	5512 067-03	5512 091-01	5680 015-01 (10.0)	5680 065-11	3113 020-406
C8-391.02-63 080A	5512 067-04	5512 091-02	5680 015-02 (14.0)	5680 065-12	3113 020-457
C8-391.02-63 120A	5512 067-04	5512 091-02	5680 015-02 (14.0)	5680 065-12	3113 020-457
C8X-391.02-63 080	5512 067-04	5512 091-02	5680 015-02 (14.0)	5680 065-12	3113 020-457
C8X-391.02-80 100	5512 067-04	5512 091-02	5680 015-02 (14.0)	5680 065-12	3113 020-509
C8X-391.02-80 150	5512 067-04	5512 091-02	5680 015-02 (14.0)	5680 065-12	3113 020-509
C10-39.01-100 140	5512 063- 14	5512 091-05	5680 015-06 (17)	5680 065-14	3113 020-561
C10-39.02- 63 095	5512 067- 04	5512 091-02	5680 015-02 (14.0)	5680 065-12	3113 020-457
C10-39.01-80 100	5512 067- 04	5512 091-02	5680 015-02 (14.0)	5680 065-12	3113 020-509

¹⁾ Accessories, must be ordered separately

Short version
Cx-391.01/ Cx-391.02
Cx-391.01R/Cx-391.02R

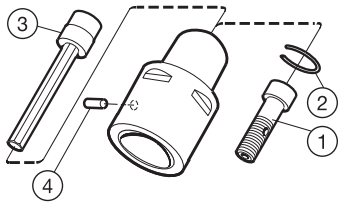

	1	2	3 ¹⁾	4
	Centre screw	Retaining ring	Extension key (mm)	Pin
C3-391.01-32 035	5512 068-01	5545 040-02	5680 015-05 (8.0)	3113 020-304
C4-391.01-40 040	5512 068-02	5545 040-03	5680 015-05 (8.0)	3113 020-355
C5-391.01-50 050	5512 068-03	5545 040-07	5680 015-05 (8.0)	3113 020-406
C6-391.01-63 060	5512 068-04	5545 040-08	5680 015-02 (14.0)	3113 020-457
C8-391.01-80 065	5512 068-05	5545 040-08	5680 015-02 (14.0)	3113 020-509
C5-391.02-32 033	5512 068-01	5545 040-02	5680 015-05 (8.0)	-
C5-391.02-40 040	5512 068-06	5545 040-07	5680 015-05 (8.0)	-
C6-391.02-32 032	5512 068-01	5545 040-02	5680 015-05 (8.0)	-
C6-391.02-40 040	5512 068-02	5545 040-03	5680 015-05 (8.0)	-
C6-391.02-50 050	5512 068-07	5545 040-08	5680 015-01 (10.0)	-
C8-391.02-50 045	5512 068-08	5545 040-08	5680 015-01 (10.0)	-
C8-391.02-63 055	5512 068-05	5545 040-08	5680 015-02 (14.0)	-
C8X-391.02-63 055	5512 068-05	5545 040-08	5680 015-02 (14.0)	-
C8X-391.02-80 065	5512 068-05	5545 040-08	5680 015-02 (14.0)	-
C10-391.02-63 055	5512 068-05	5545 040-08	5680 015-02 (14.0)	3113 020-457
C10-391.02-80 065	5512 068-05	5545 040-08	5680 015-05 (8.0)	3113 020-509
C5-391.01R-50 050	5512 068-03	5545 040-07	5680 015-02 (14.0)	3113 020-409
C8-391.01R-63 060	5512 068-04	5545 040-08	5680 015-02 (14.0)	3113 020-457
C8-391.01R-80 065	5512 068-05	5545 040-08	5680 015-02 (14.0)	3113 020-509
C8-391.02R-63 055	5512 068-05	5545 040-08	5680 015-02 (14.0)	-

¹⁾ Accessories, must be ordered separately

Collet chuck adaptors

Cx-391.14

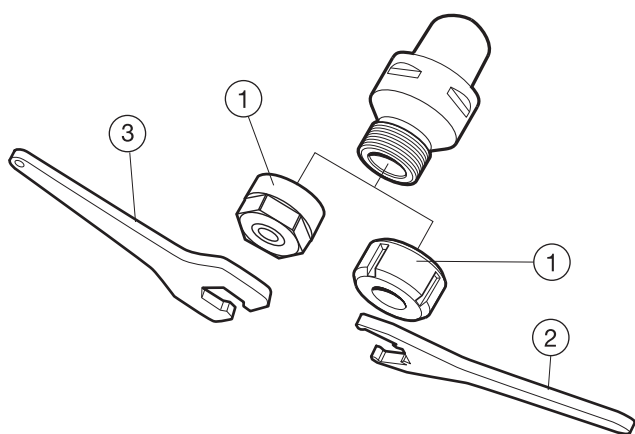

	1	2 ¹⁾	3 ¹⁾
	Locking nut	Wrench	Wrench
Cx-391.14-16 xxx	5533 050-06	-	5680 091-01
Cx-391.14-20 xxx	5533 050-08	-	5680 091-02
Cx-391.14-25 xxx	5533 050-02	5680 096-02	-
Cx-391.14-32 xxx	5533 050-03	5680 096-03	-
Cx-391.14-40 xxx	5533 050-04	5680 096-04	-
Cx-391.14-50 xxx	5533 050-05	5680 096-05	-

¹⁾ Accessories, must be ordered separately

Tap adaptors

Cx-391.60A

Cx-391.60B

B

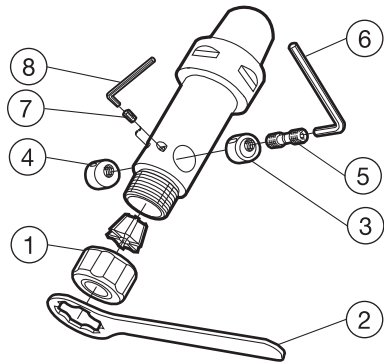

C

	1	2 ¹⁾	3	4
Cx-391.60A- Cx-391.60B-	Locking nut	Wrench	Jaw right	Jaw left
01 xxx	391.60A-OZ 3158	5680 090-01	5412 093-01	5412 093-02
02 xxx	391.60A-OZ 3159	5680 090-02	5412 093-01	5412 093-02
03 xxx	391.60A-OZ N460	5680 092-01	5412 093-03	5412 093-04
	5	6 ¹⁾	7	8 ¹⁾
Cx-391.60A- Cx-391.60B-	Adjusting screw	Key for jaws (mm)	Socket screw	Key (mm)
01 xxx	5516 050-01	3021 010-040 (4.0)	3214 020-255	174.1-870 (2.0)
02 xxx	5516 050-01	3021 010-040 (4.0)	3214 020-255	174.1-870 (2.0)
03 xxx	5516 050-02	3021 010-050 (5.0)	3214 020-305	174.1-863 (2.5)

1) Accessories, must be ordered separately

G

Set of spare parts

391.60/392.41060/393.2060

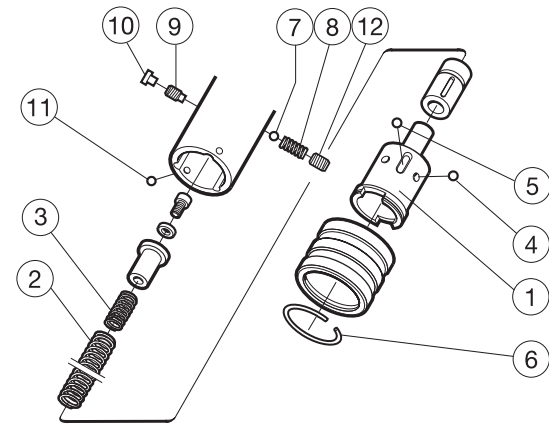

	Adaptor size		
	393.2060-xx01	393.2060-xx02	393.2060-xx03
	392.41060-xx01	392.41060-xx02	392.41060-xx03
	Cx-391.60/61-01	Cx-391.60/61-02	Cx-391.60/61-03
Barrel	5638 055-01	5638 055-02	5638 055-03
Complete spare part set items 2-12	5471 020-01	5471 020-02	5471 020-03

- 1. Barrel
- 2. Compression spring
- 3. Compression spring
- 4. Ball
- 5. Ball
- 6. Circlip
- 7. Ball
- 8. Compression spring
- 9. Stop screw
- 10. Plastic plug
- 11. Clamp ring (size 1)
- 12. Screw

For technical information, see Metalcutting Technical guide.

J