

T-Max U-Lock® SL cutting head

Screw clamp design

Internal cutting fluid supply



166.0L,
154.0G¹⁾

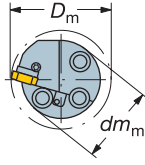
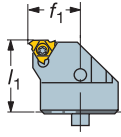

x and z, see infeed tables on pages C58.

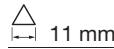

No shims used.

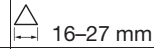
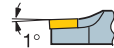

Angle of inclination from -2° to +4° with different shims, see page C58.

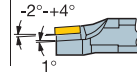

Right hand style shown

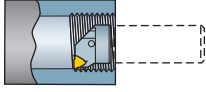
Main application	△	Pitch range		Ordering code	Dimensions, mm				
		mm	t.p.i.		dm _m	D _m min	f ₁	l ₁	Nm ²⁾
	11	0.5-2.0	32-14	R/L566.0KFC-162012-11	16	20	12.0	20	0.9
				R/L566.0KFC-202014-11	20	25	14.0	20	0.9
	16	0.5-3.0	32-8	R/L566.4KFC-252517-16	25	32	17.0	25	1.7
				R/L566.4KFC-323222-16	32	40	22.0	32	1.7
				R/L566.4KFC-403227-16	40	50	27.0	32	1.7
				R/L566.4KFC-504035-16	50	63	35.0	40	1.7
				R/L566.4KFC-604043-16	60	80	43.0	40	1.7
	22	3.5-6.0	7-4	R/L566.4KFC-252819-22 ³⁾	25	32	19.0	28	3.9
				R/L566.4KFC-323222-22	32	40	22.0	32	3.9
				R/L566.4KFC-403227-22	40	50	27.0	32	3.9
			R/L566.4KFC-504035-22	50	63	35.0	40	3.9	
			R/L566.4KFC-604043-22	60	80	43.0	40	3.9	
27	8.0	3	R566.0KFC-403627-27	40	50	27.0	36	9.5	
			R566.0KFC-504435-27	50	63	35.0	44	9.5	
			R566.0KFC-604343-27	60	80	43.0	43	9.5	

²⁾ Insert tightening torque Nm
³⁾ No shims used.

Ordering example: 2 pieces R566.0KFC-162012-11
 2 pieces L566.0KFC-162012-11
 R = Right hand, L = Left hand

¹⁾ When using U-Lock circlip grooving inserts, type R/L 154.0G, the right hand round shank tool uses a left hand insert and the left hand round shank tool a right hand insert. A shim giving 0° inclination must be used, see page C58.

Main spare parts

Insert size

△	∅ dm _m	Insert screw	Key (Torx Plus)	Shim ⁵⁾ Inclination angle +1°	Shim screw	Key (Torx Plus/mm)
11	-	5513 020-03	5680 051-02 (7IP)	-	-	-
16	25-60	5513 026-01	5680 051-03 (9IP)	5322 361-11	5512 032-01	170.3-865 (9IP)
22	25	5513 026-04	5680 049-02 (15IP)	-	-	-
	32-60	5513 026-04	5680 049-02 (15IP)	5322 365-11	5512 032-02	5680 016-02 (15IP)
27	27	5513 0206-14	5680 043-15 (25IP)	3522 383-11	5512 090-08	3021 010-060 (6.0)

⁵⁾ For optional shims, see page C58.



C4



A219



C49



C2

T-Max U-Lock® cartridges

Screw clamp design



166.0L,
154.0G¹⁾

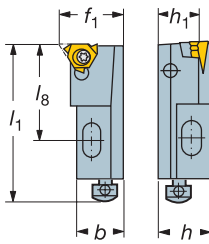

x and z, see infed tables on pages C57.

Angle of inclination from -2° to $+4^\circ$ with different shims, see page C58.

Right hand style shown

Main application	\triangle	Pitch range		Ordering code	Dimensions, mm						Nm ²⁾
		mm	t.p.i.		b	f ₁	l ₁	h	h ₁	l ₈	
	16	0.5-3	32-8	R466.4KF-16CA-16	19	25.0	63	21	16	38	1.7
	22	3.5-6	7-4	R/L466.4KF-20CA-22	16	25.0	70	21	20	40	3.9

²⁾ Insert tightening torque Nm

Ordering example: 2 pieces R466.4KF-16CA-16
2 pieces L466.4KF-16CA-16
R = Right hand, L = Left hand

¹⁾ When using U-Lock circlip grooving inserts, type R/L 154.0G, the right hand cutting head uses a left hand insert and the left hand cutting head a right hand insert. A shim giving 0° inclination must be used, see page C58.

Main spare parts

Insert size

\triangle	Insert screw	Key (Torx Plus)	Shim Inclination angle $+1^\circ$	Shim screw	Key (Torx Plus)
16	5513 026-01	5680 051-03 (9IP)	5322 361-11	5512 032-01	5680 016-03 (9IP)
22	5513 026-02	5680 049-02 (15IP)	5322 365-11	5512 032-02	5680 016-02 (15IP)

Mounting dimensions for T-MAX U-Lock cartridges

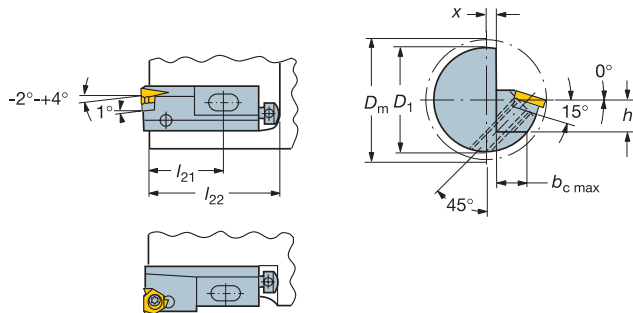
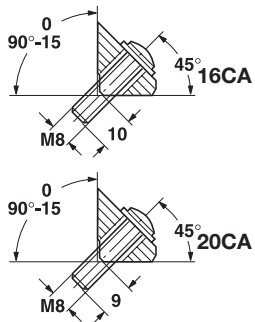

$$D_1 = 2 \sqrt{h_1^2 + (b_{c \max} + (-) x)^2}$$

$$x = \frac{D_m}{2} - f_1$$

Angle of inclination from -2° to $+4^\circ$ with different shims, see page C58.

Cartridge code

	D _m min	D ₁ min	x	l ₂₁ min	l ₂₂	h ₁	b _c max
R/L 466.4KF-16CA-16	55	50	4.47	35	60	16	15
R/L 466.4KF-20CA-22	60	55	6.63	37	67	20	12.2



C4



C49



C2

Code key – T-MAX Twin-Lock® for oil pipe threading

T-Max Twin-Lock® holders

R	166.39	FG	-	3232	-	24
1	2	3		4		5

1 Hand of tool

2 Main code

R = Right hand style

166.39 = Twin-Lock® shank holder
 466.39 = Twin-Lock® cartridge
 566.39 = Twin-Lock® SL cutting head

3 Type of tool and holder style

External

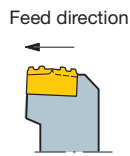

FG

Internal

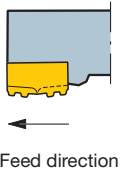

KF

4 Toolholder dimensions

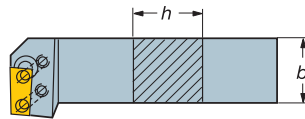
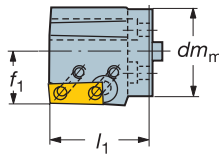
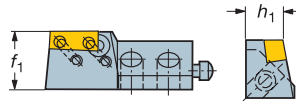
Shank tool
 $h \times b$ T-Max Twin-Lock® SL cutting head
 $dm_m \times l_1 \times f_1$ Cartridge
 $h_1 \times f_1$ 

5 Insert dimension

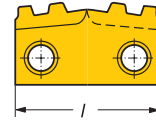
Insert size (l), in mm
 $l = 24.0$ mm

T-MAX Twin-Lock® inserts

R	166.39	G	-	24	RD1	3	-	080
1	2	3		4	5	6		7

1 Hand of insert

2 Main code

3 Type of machining

4 Insert dimension

R = Right hand style insert

166.39 = T-Max Twin-Lock®

G = Inserts for external threading

Length (l), in mm
 $l = 24.0$ mm

L = Inserts for internal threading

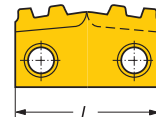

5 Thread profile

RD0 = API Round Vee tubing and casing

RD1 = API Round Vee tubing and casing

BU1 = API Buttress = 13 3/8" (3/4" i.p.f)

BU2 = API Buttress = 16" (1" i.p.f)

6 Number of points per cutting edge

Varies from 1 to 7 points.

7 Pitch

Number of threads per inch x 10

The T-MAX Twin-Lock system

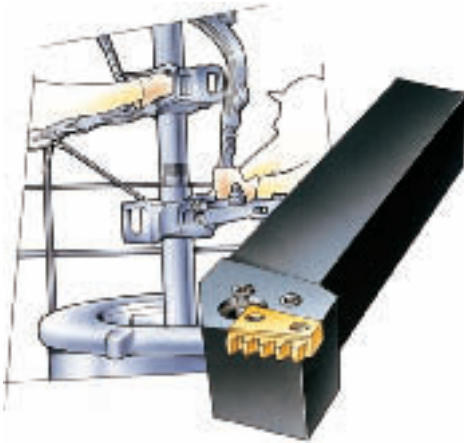

T-Max Twin-Lock® is a system that well suits the wide and varying aspects and requirements of the oil related industry, primarily for use in the high volume area of tubing, casing and coupling production.

Tool joint and rotary shouldered connection threads are also covered by the system where the excellent indexing accuracy, security of edge and repeatability are ideally suited to the modern production units.

External and internal threading inserts for tubes and casings

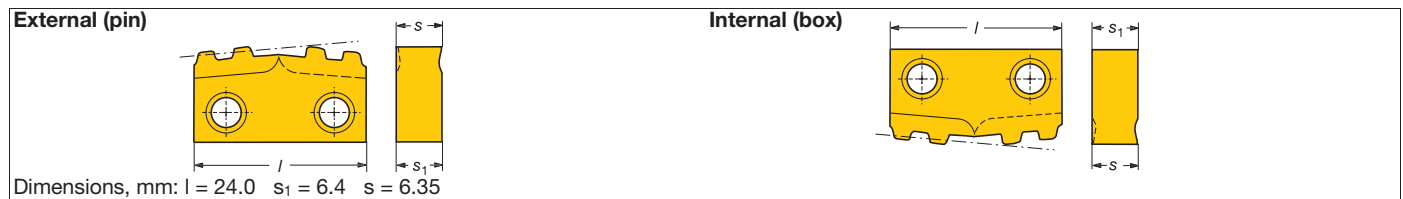

Component range	Thread form	Pitch	Taper on dia	Ordering code	No. of points	Coromant grades		
						4125		
	Double sided	t.p.i.	i.p.f.					
API NU Tubing 1.050" – 3 1/2"	API Round Vee			External				
API EU Tubing 1.050" – 1.900"		10	3/4	R166.39G-24RD03-100	3+3	☆		
API IJ Tubing 1.315" – 2 1/16"		10	3/4	R166.39L-24RD04-100¹⁾	4+4	☆		
API NU Tubing 4" – 4 1/2"	API Round Vee			External				
API EU Tubing 2 3/8" – 4 1/2"		8	3/4	R166.39G-24RD13-080	3+3	☆		
API SR Casing 4 1/2" – 20"		8	3/4	R166.39L-24RD04-080¹⁾	4+4	☆		
API LR Casing 4 1/2" – 20"	API Buttress			External				
API Buttress Casing 4 1/2" – 13 3/8"		5	3/4	R166.39G-24BU12-050	2+2	☆		
		5	3/4	R166.39L-24BU12-050¹⁾	2+2	☆		
API Buttress Casing ≥ 16"	API Buttress			External				
		5	1	R166.39G-24BU22-050	2+2	☆		
		Rougher	5	1	R166.39L-24BU22-050¹⁾	2+2	☆	

¹⁾ Are to be used in holders giving 10° inclination angle.

Ordering example: 10 pieces R166.39G-24RD03-100 4125
R = Right hand



C44



G6



C2

A
General Turning
B
Parting and Grooving
C
Threading
D
Milling
E
Drilling
F
Boring
G
Toolholding Systems
H
Multi-Task Machining
I
General Information

THREADING T-Max Twin-Lock® for oil pipe threading

Lever design

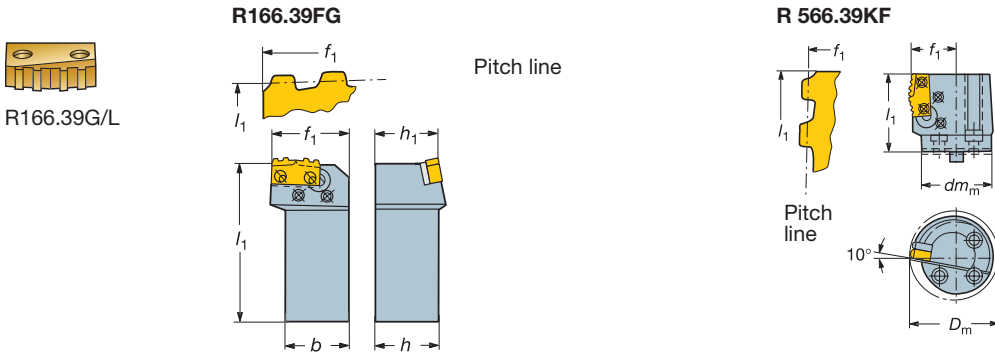

Right hand style shown

Shank tools

Main application	Pitch range	Ordering code	Dimensions, mm				
	Pitch, t.p.i.		<i>b</i>	<i>f</i> ₁	<i>l</i> ₁	<i>h</i>	<i>h</i> ₁
	10-4	R166.39FG-3232-24	32	38.6	148.4	32	32

Ordering example: 2 pieces R166.39FG-3232-24
R = Right hand

T-Max Twin-Lock® SL cutting head

Main application	Pitch range	Ordering code	Dimensions, mm			
	Pitch, t.p.i.		<i>D</i> _m min	<i>f</i> ₁	<i>l</i> ₁	<i>dm</i>
	10-4	R566.39KF-404527-24 ¹⁾	60.3	25.8	44.2	40

¹⁾ Only for API Round Vee inserts, 8 and 10 t.p.i.

Ordering example: 2 pieces R566.39KF-404527-24
R = Right hand

Main spare parts

Insert size				
	Lever	Screw	Key (mm)	Shim
24	5432 005-01	174.3-820M	170.3-860 (2.5)	5321 110-01



Cartridge

Lever design



R166.39G/L

R 466.39KF

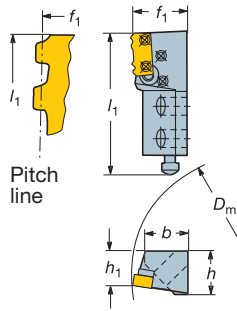

Right hand style shown

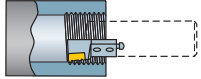
Main application	Pitch range	Ordering code	Dimensions, mm					
	Pitch, t.p.i.		D_m min	b	f_1	l_1	h	h_1
	10-5	R466.39KF-1832-24	114	25	30.0	80	24	18

Ordering example: 2 pieces R466.39KF-1832-24
R = Right hand

Main spare parts

Insert size

	Lever	Screw	Key (mm)	Shim
24	5432 005-01	174.3-820M	170.3-860 (2.5)	5321 110-01

T-Max P cartridge for rough threading

Lever design



-  TNMM
-  TNMG
-  TNMA

R 466.39KW

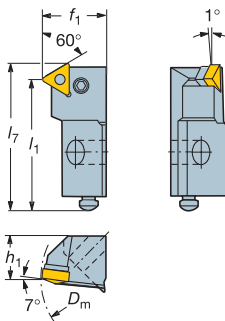

Right hand style shown

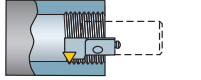
Main application		Ordering code	Dimensions, mm						
			D_m min	b	f_1	l_1	h	h_1	l_8
	16	R466.3KW-2030-16	79	20	29.72	59.7	26	20	29.7

Main spare parts

Insert size

	Lever	Screw	Key (mm)	Shim
16	174.3-840M	174.3-820M	170.3-860 (2.5)	179.3-850M



C43



C50



C2

This catalogue has been split into smaller parts
to enhance downloading speeds.

If you want to view the next page
please click [HERE!](#)