

Parts List and

Operating Instructions for:

	PH63C
	PH83C
PH6	PH113C
PH8	PH303C
PH11	HST11
PH30	HST11S

HYDRA-GRIP-O-MATIC® PULLER AND STRAIGHTENER TOOL

Max. Capacity: 6 Ton (PH6 & PH63C); 8 Ton (PH8 & PH83C); 15 Ton (PH11, PH113C, & HST11);
30 Ton (PH30 & PH303C)

NOTE:

- These instructions must be read and carefully followed.
- Carefully inspect the puller and/or straightener tool upon arrival. The carrier, not the manufacturer, is responsible for any damage resulting from shipment.



SAFETY PRECAUTIONS

WARNING: To help prevent personal injury,

- These pullers and the straightener tool should be used only by trained personnel familiar with them.
- Safety glasses must be worn at all times by the operator and anyone within sight of the puller and straightener tool.
- Select the proper size and capacity of puller for the job.
- Align the puller on the same centerline as the part being removed. Failure to align parts correctly can result in a dangerous operating situation because of the high hydraulic pressures used.
- Wrap the work in a Power Team protective blanket before applying pressure to provide protection from injury caused by flying parts should a part ever break.
- Always apply force gradually.

IMPORTANT: DO NOT USE HEAT, HAMMERS, OR IMPACT TOOLS ON THESE PULLERS.
THIS WILL CAUSE DAMAGE THAT VOIDS THE PULLER WARRANTY.

PULLER SETUP AND OPERATION

NOTE: These pullers have a 2/3-way combination puller head. The 3-jaw combination is strongly recommended whenever the job space allows for it. Three jaws give a more secure grip and more even pulling force.

1. Select the proper size and capacity of puller needed for the job. This is determined by measuring "reach" and "spread" of the part to be pulled.
2. Place the handle assembly into the handle clevis.
See Figure 1.

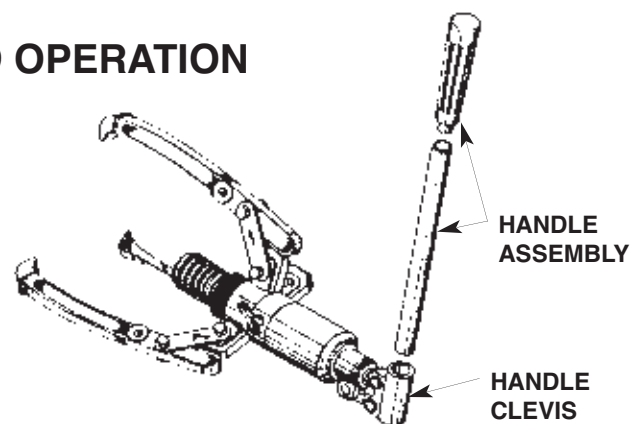

Figure 1

PULLER SETUP AND OPERATION (CONTINUED)

- Turn the control valve knob completely in a clockwise direction to advance the piston. See Figure 2.

IMPORTANT: Position the control valve knob so it does not contact the puller head and can be turned freely.



CONTROL VALVE KNOB

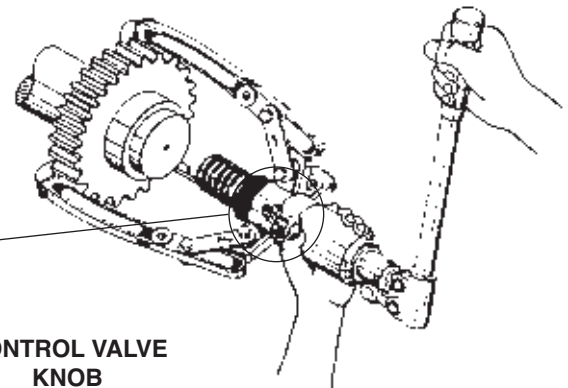

Figure 2

- Begin positioning the puller and puller jaws around the part to be pulled, removing most of the slack by threading the adjusting locknut further onto the puller body or adjusting the puller straps on the jaws. Pump the handle to advance the piston, stopping just as the removable cone reaches the part. Make final puller positioning adjustments with the adjusting locknut or the piston. The puller must be on the same centerline as the part to be pulled and the jaws fully engaged and secure. See Figure 3.



WARNING: The adjusting locknut must be fully engaged with the threads of the puller body as shown below on all 6, 8, & 15 Ton pullers. On 30 ton puller, full thread engagement minimum crosshead required.

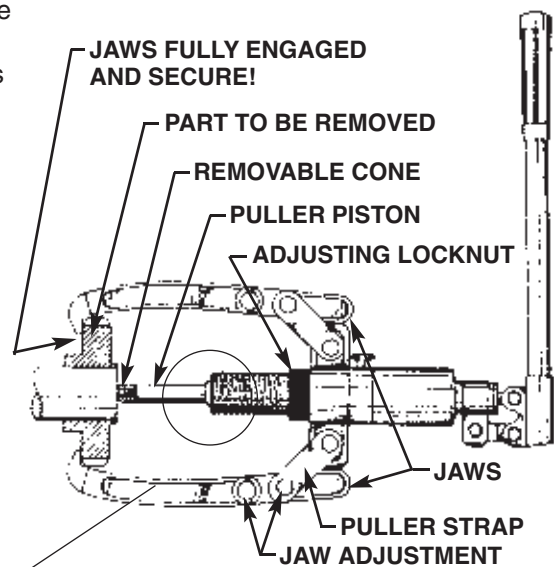
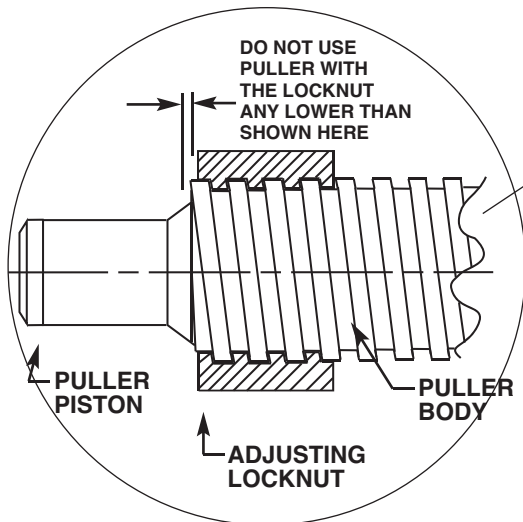

Figure 3



- The handle assembly rotates a full 360° to allow the best handle location for the job. See Figure 4.

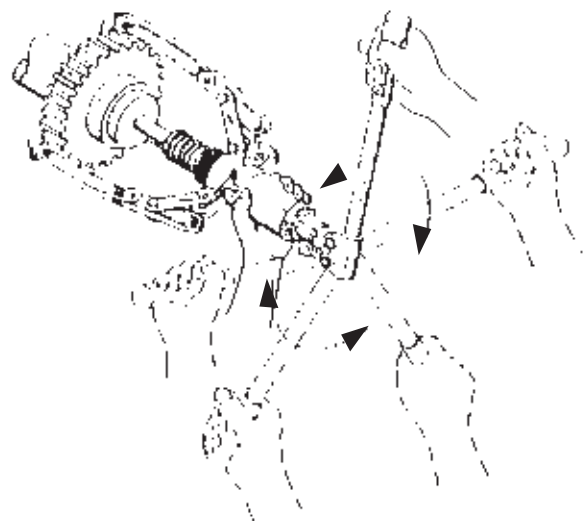

Figure 4

PULLER SETUP AND OPERATION (CONTINUED)

6. Hold the puller with one hand and pump the handle with your other hand, advancing the piston until the part is removed. See Figures 5 & 6.

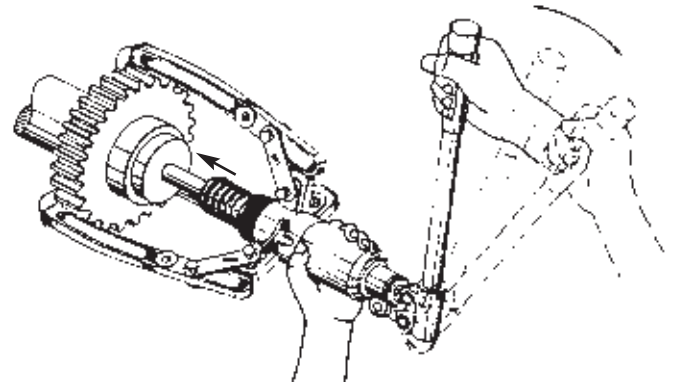

Figure 5

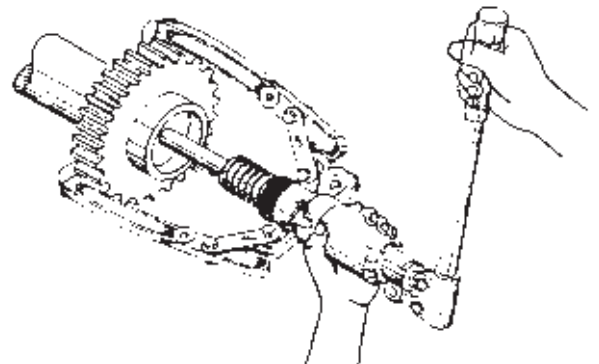

Figure 6

7. Turn the control valve knob completely in a counterclockwise direction to retract the piston. See Figure 7.

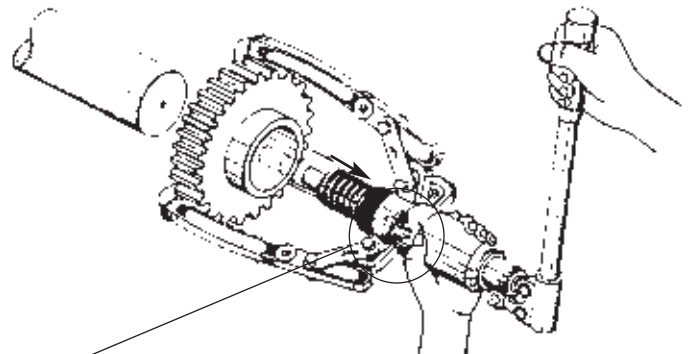
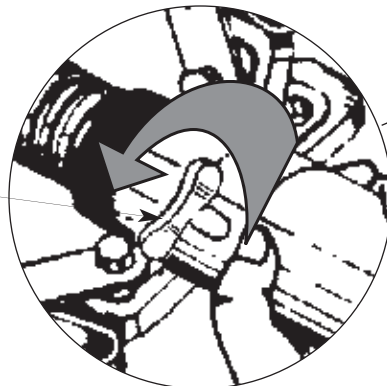
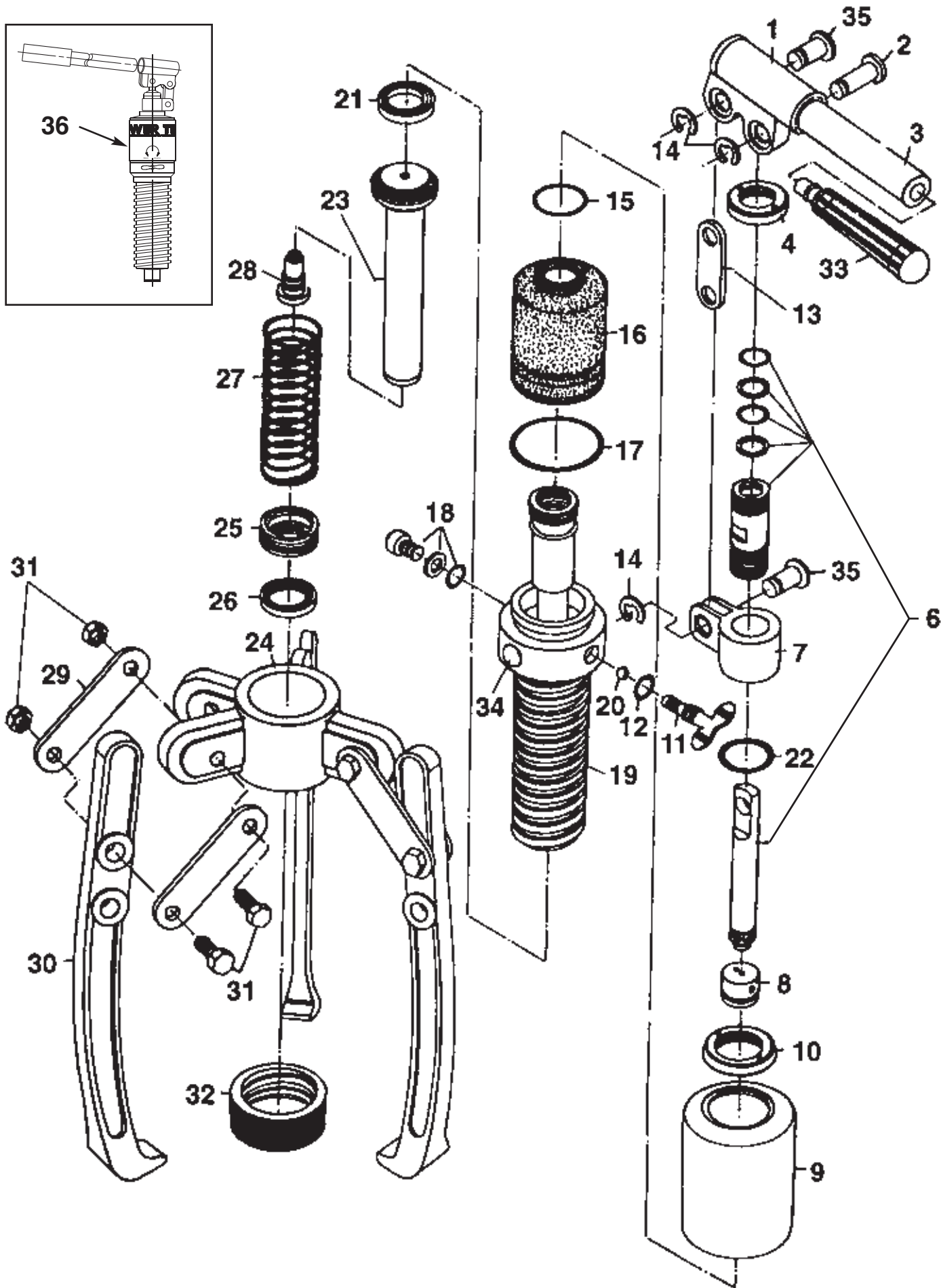
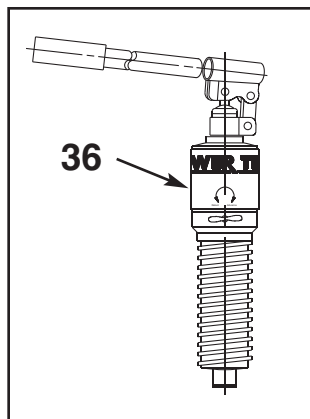

Figure 7

CONTROL VALVE
KNOB



PULLER PARTS LIST



Item No.	Part No. (For PH63C)	Part No. (For PH83C)	Part No. (For PH113C)	No. Req'd	Description
1				1	Handle Clevis
2				1	Clevis Pin - Long
3				1	Handle Lever
4				1	Retainer Nut
6				1	Pump Housing and Piston Rod Assembly
7				1	Swivel Clevis
8				1	Inlet/Outlet Valve Assembly
9				1	Bladder Housing
10				1	Bladder Housing Retainer Nut
11				1	Control Valve Knob
12				1	O-ring
13				1	Link Connector
14				3	Retaining Ring
15				1	Compression Ring - Small
16				1	Reservoir Bladder
17				1	Compression Ring - Large
18				1	Oil Fill Screw Assembly
19				1	Hydraulic Puller Body
20				1	Steel Ball
21				1	U-cup
22				1	O-ring
23				1	Puller Piston Rod
24				1	Puller Crosshead
25				1	Cylinder Retaining Nut
26				1	Rod Wiper
27				1	Compression Spring
28				1	Removable Cone Assembly
29				6	Puller Strap
30				3	Puller Jaw
				3	Long Puller Jaw (Optional)
31				6	Puller Jaw Screw and Nut
32				1	Adjusting Locknut
33				1	Handle Grip Assembly
34				1	See Note Below
35				2	Clevis Pin - Short
36	PH6	PH8	PH11	1	Replacement Hydraulic Assembly Complete w/ Handle

Contact Tech Support at 800-477-8326 with parts inquiries.

PARTS INCLUDED BUT NOT SHOWN

351491	351492	351493	1	Trade Name Decal
252948	252949	252950	1	Plastic Case

*To order a set of three long jaws, order No. 1188.

NOTE: Relief Valve Assembly (Item #34) must not be serviced except by a qualified hydraulic service center. Contact your nearest service center or Power Team Technical Services for further information.

PREVENTIVE MAINTENANCE

- Keep the puller as clean as possible to help prevent contamination from entering the hydraulic system and to prevent rust.
- If additional oil is needed, use Power Team hydraulic oil or a comparable jack oil.

Reservoir oil capacity:	PH6 & PH63C = .19 pt (90 cc)	PH11 & PH113C = .32 pt (150 cc)
	PH8 & PH83C = .25 pt (120 cc)	

- Periodically lubricate puller pivot points.
- Store the puller and all accessories in its plastic case.

PULLER PARTS LIST-PH303C

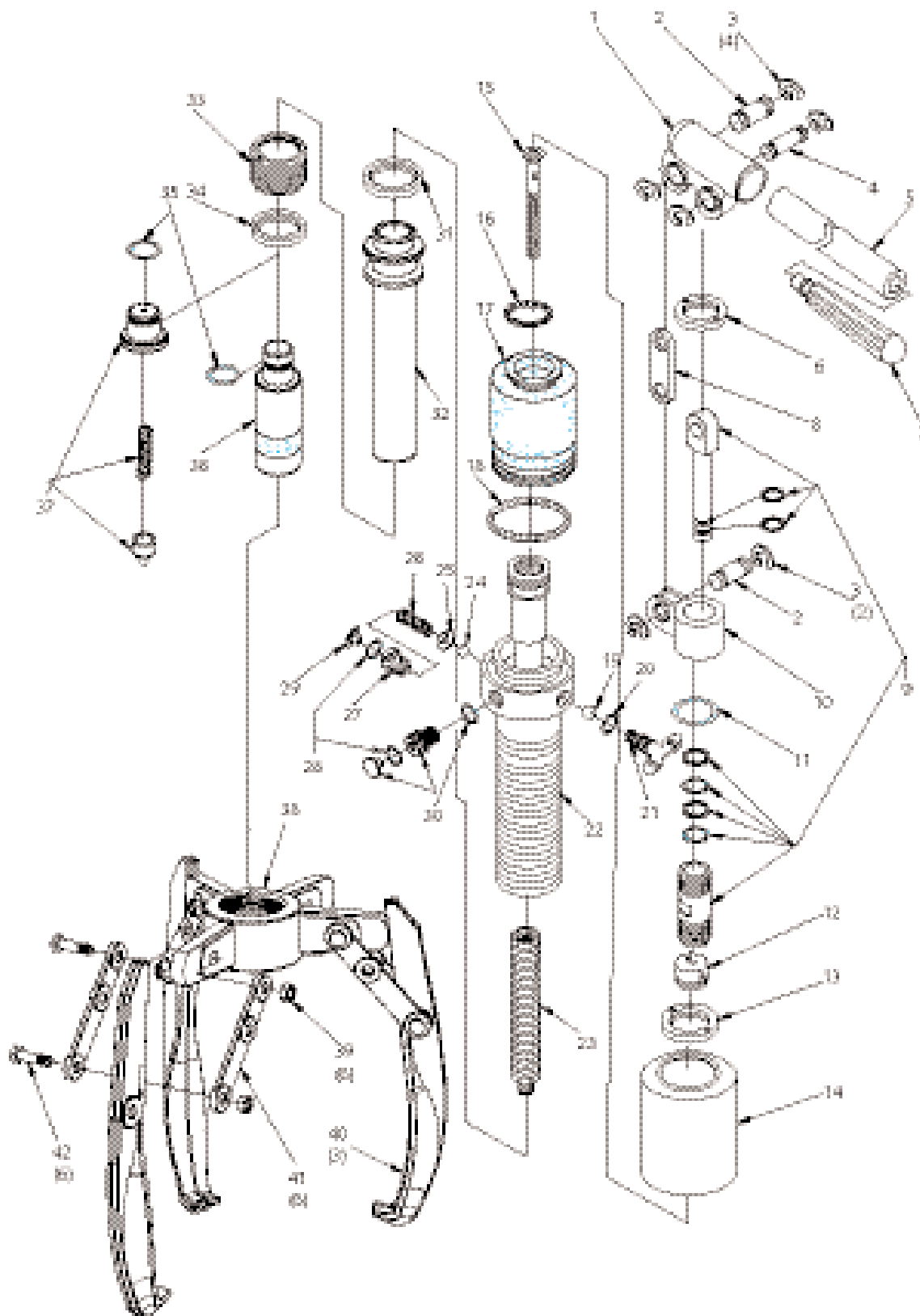

PH303C PULLER, HYD. GEAR 30 TON, W CASE & BLANKET

ITEM	SPX NO.	QTY P/N	DESCRIPTION
1	252926	1	Clevis, Handle
2	2000616	2	Pin, Clevis - Short
3	252932	6	Ring, Retaining
4	2000620	1	Pin, Clevis - Long
5	252936	1	Lever, Handle
6	252941	1	Nut, Retainer (Nut, Cylinder Retaining)
7	252957	1	Assembly, Handle Grip
8	252925	1	Link, Connector
9	252914	1	Assembly, Pump Housing Pump and Piston
10	252912	1	Clevis, Swivel
11	252940	1	O-ring
12	252913	1	Assembly, Inlet / Outlet Valve
13	2000599	1	Nut, Retainer Housing Bladder
14	2000598	1	Housing, Bladder
15	2000621	1	Screw, Drag Spring
16	252887	1	Ring, Compression - Small (Spring)
17	2000601	1	Bladder, Reservoir
18	2000602	1	Ring, Compression - Large (Spring)
19	252916	1	Ball, Steel .250"
20	252902	1	O-ring
21	2000600	1	Knob, Valve Control
22	2000603	1	Body, Hydraulic Puller
23	2000622	1	Spring, Drag
24		1	
25		1	
26		1	
27		1	
28		2	
29		1	
30	2000629	1	Screw, Ass'y Oil Fill
31	2000604	1	U-cup
32	2000605	1	Rod, Piston Puller
33	2000607	1	Nut, Cylinder Retaining
34	2000608	1	Wiper, Rod Nitrile
35	2000630	2	O-ring
36	2000631	1	Adapter
37	2000632	1	Cone Assembly, Removable
38	2000606	1	Crosshead, Puller
39	2000614	6	Nut, Puller Jaw
40	2000612	3	Jaw, Puller
41	2000611	6	Strap, Puller
42	2000609	6	Screw, Puller Jaw
43			
44	2000613	3	Jaw, Long Puller (Optional, Not Shown)
45	2000617	1	Case, Metal Storage
46	2000618	1	Blanket, Protective
47	1000199	1	Decal
48	PH30	1	Pump, Replacement Assembly

NOTE: Relief Valve Assembly (Item #24–#29) must not be serviced except by a qualified hydraulic service center. Contact your nearest service center or Power Team Technical Services for further information.

PREVENTIVE MAINTENANCE

- Keep the puller as clean as possible to help prevent contamination from entering the hydraulic system and to prevent rust.
- If additional oil is needed, use Power Team hydraulic oil or a comparable jack oil.

- Reservoir oil capacity:

PH30 & PH303C = .68 pt (320 cc)

- Periodically lubricate puller pivot points.
- Store the puller and all accessories in its plastic case.

Sheet No. 4 of 5

Rev 10 Date: 30 Mar 2006

STRAIGHTENER TOOL SETUP AND OPERATION

1. Thread the straightener tool onto the puller body. See Figure 8.

WARNING: The straightener tool must be fully engaged with the threads of the puller body as shown below.

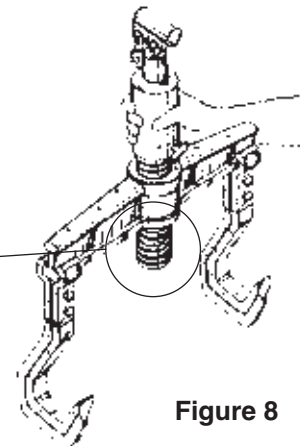
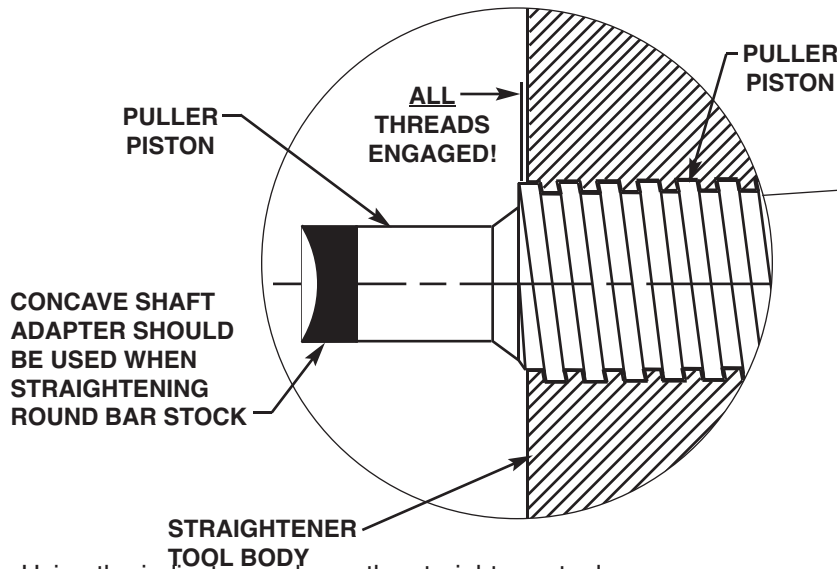

2. Using the indicator marks on the straightener tool body, position the straightener tool arms an equal distance apart from the center of the puller body. See Figure 9.

WARNING: Failure to equally position the straightener tool arms on the straightener body creates a very dangerous situation. The force will be unevenly distributed to each arm causing tool breakage and personal injury.

IMPORTANT: DO NOT USE HEAT, HAMMERS, OR IMPACT TOOLS ON THESE PULLERS. THIS WILL CAUSE DAMAGE THAT VOIDS THE PULLER WARRANTY.

3. Place the handle assembly into the handle clevis. See Figure 9.
4. Place puller and tool on a bar or round bar stock to be straightened. Turn the control valve knob completely in a clockwise direction to advance the piston. See Figure 9.

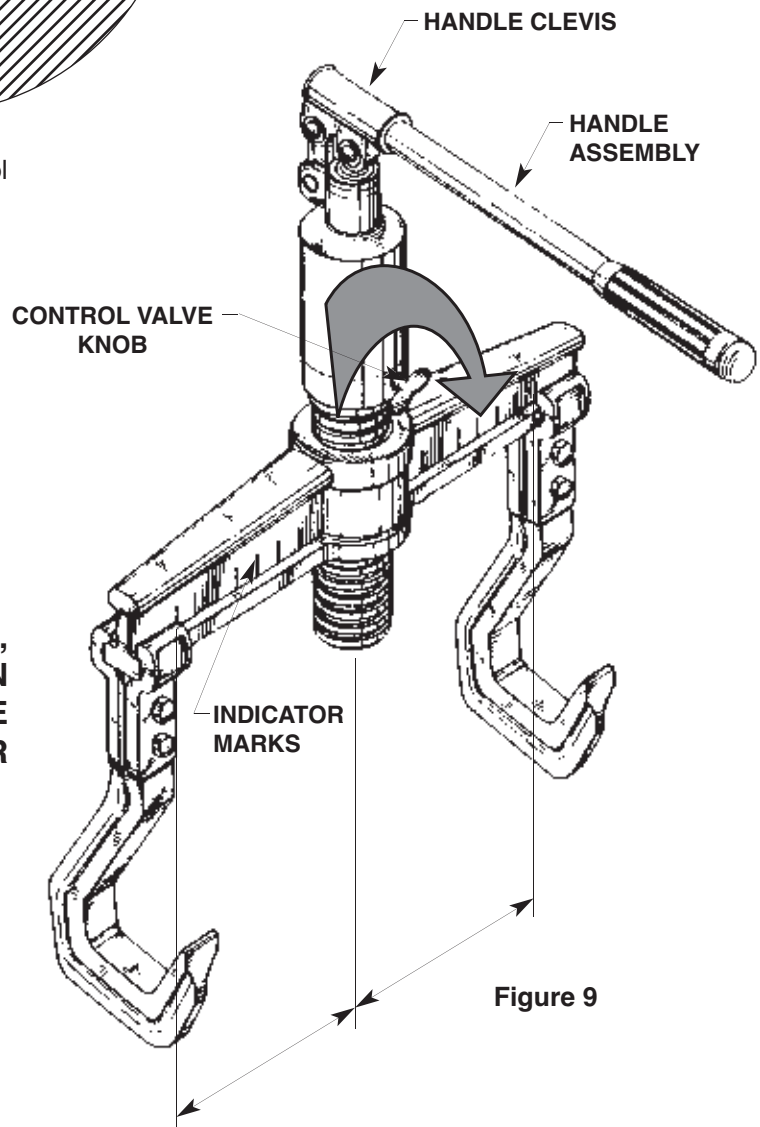

STRAIGHTENER TOOL SETUP AND OPERATION (CONTINUED)

5. Advance the piston by pumping on the handle until the bar or round bar stock is straight. See Figure 10.
6. Turn the control valve knob completely in a counterclockwise direction to retract the piston. See Figure 10.

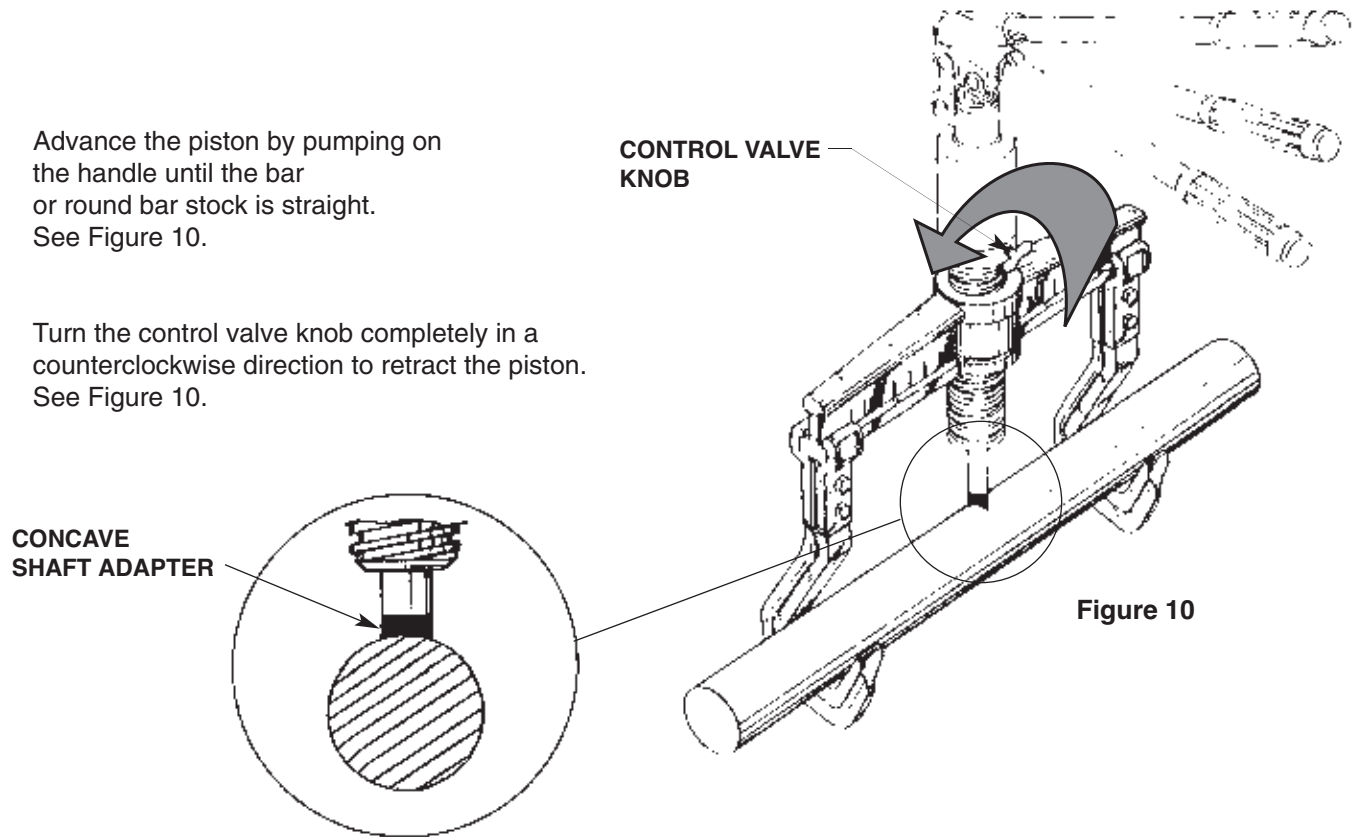

HST11 STRAIGHTENER TOOL PARTS LIST

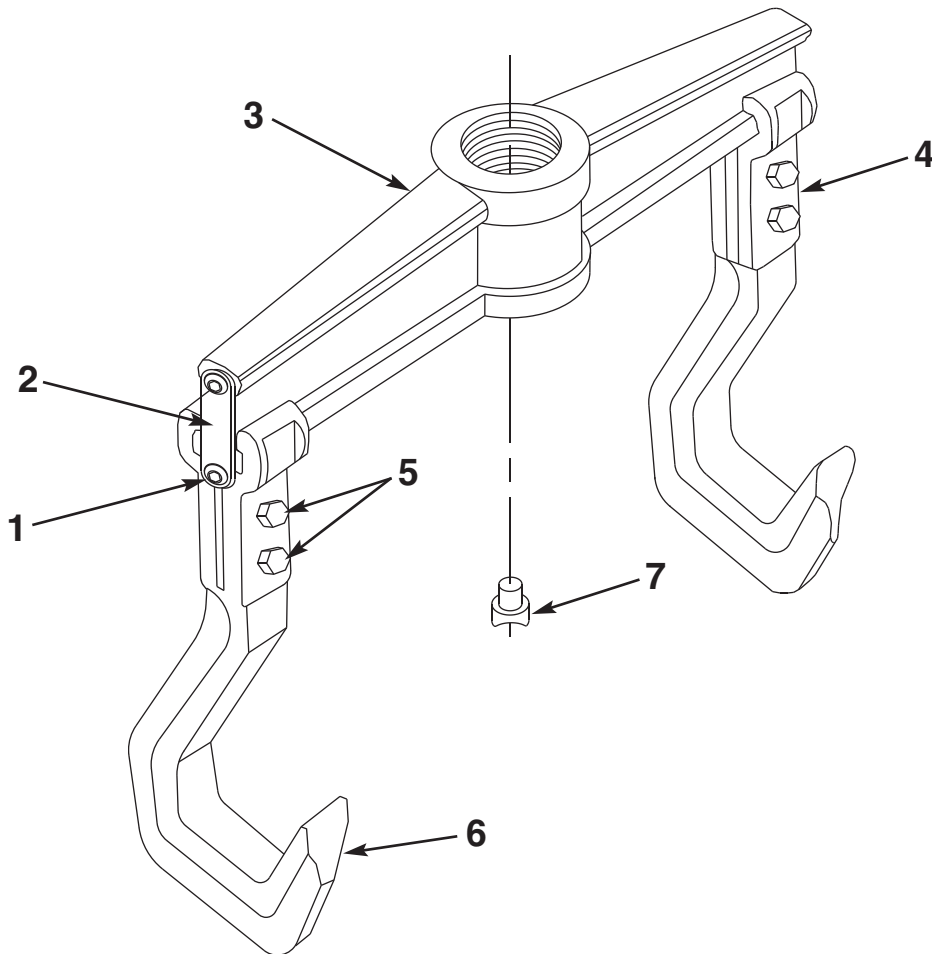

Item No.	Part No.	No. Req'd	Description
1	253042	4	Screw
2	253041	2	Strap
3	253037	1	Crossbar
4	253038	2	Jaw Holder
5	253040	4	Nut and Bolt Assembly
6	253039	2	Jaw
7	253060	1	Concave Ram Cap (Assemble to piston rod of puller.)

PARTS INCLUDED BUT NOT SHOWN

222142	1	Warning Decal
351563	1	Trade Name Decal
PH11	1	Hydraulic Puller Assembly Complete (With handle, also see back sheet 2 of 4 and 3 of 4)

NOTE: HST11S is a set consisting of HST11 straightener tool and PH11 hydraulic puller with handle.