



---

MODEL A  
**FLANGE SPREADER**  
Max. Pressure: 10,000 PSI (700 BAR)  
Unit Weight: 9 LBS. (4.08 Kg)

**Definition:** To break loose or spread pipe flange couplings.

- Carefully inspect the unit upon arrival. The carrier, not the manufacturer, is responsible for any damage resulting from shipment.
- These instructions should be read and carefully followed. Most problems with new equipment are caused by improper operation or installation.

## SAFETY EXPLANATIONS

Two safety symbols are used to identify any action or lack of action that can cause personal injury. Your reading and understanding of these safety symbols is very important.



**DANGER** - Danger is used only when your action or lack of action will cause serious human injury or death.



**WARNING** - Warning is used to describe any action or lack of action where a serious injury can occur.

**IMPORTANT** - Important is used when action or lack of action can cause equipment failure, either immediate or over a long period of time.

## **SAFETY PRECAUTIONS**

These instructions are intended for end-user application needs. Many problems with new equipment are caused by improper operation or installation. For a detailed parts list or to locate a Power Team Authorized Hydraulic Service Center contact your nearest Power Team facility. A list of all Power Team facilities is located at the end of this document.



**WARNING:** It is the operator's responsibility to read and understand the following safety statements,

- Only qualified operators should install, operate, adjust, maintain, clean, repair, or transport this machinery.
  - These components are designed for general use in normal environments. These components are not specifically designed for lifting and moving people, agri-food machinery, certain types of mobile machinery or special work environments such as: explosive, flammable or corrosive. Only the user can decide the suitability of this machinery in these conditions or extreme environments. Power Team will supply information necessary to help make these decisions.
- 



**DANGER:**

- Do not exceed the rated capacity of the Flange Spreader. Using the Flange Spreader in an application beyond its capacity could cause tool damage and result in personal injury.
- Stand to one side when applying hydraulic pressure.



**WARNING:**

- The following procedures should only be performed by qualified, trained personnel who are familiar with this equipment. Operators must read and understand all safety precautions and operating instructions.
- Keep hands and fingers clear of the blade end of this tool at all times.
- The adjustable jaws must be up against the flanges to prevent bending the pin.
- Safety glasses must be worn at all times to help prevent eye injury.
- Relieve any pressure and drain the contents of the pipe before separating the flange. Failure to do so could cause personal injury.
- A manually operated hydraulic pump must be used with the Flange Spreader to give the operator the greatest control over the spreading process.

**IMPORTANT:**

- Keep hydraulic coupler and adapter free of any dirt or water.
- Use only Power Team hydraulic fluid. Never use brake fluid or transmission oil.
- Do not spread flanges having a total thickness of more than 3-1/2".

## OPERATING INSTRUCTIONS

1. Coat the adjustable jaws, pin, and angled surfaces of the blade with the lubricant provided.
2. Couple the pump to the Flange Spreader. The blade should be fully retracted at this time.

### IMPORTANT:

- **Do not spread flanges having a total thickness of more than 3-1/2".**
3. Position the adjustable jaws of the Flange Spreader against the flange face, and install the pin through the jaws and the flange holes.
  4. Slowly extend the cylinder while positioning the blade into the opening in the flange.  
**Note: For maximum pin life always adjust the spreader jaws against the flange as shown.**

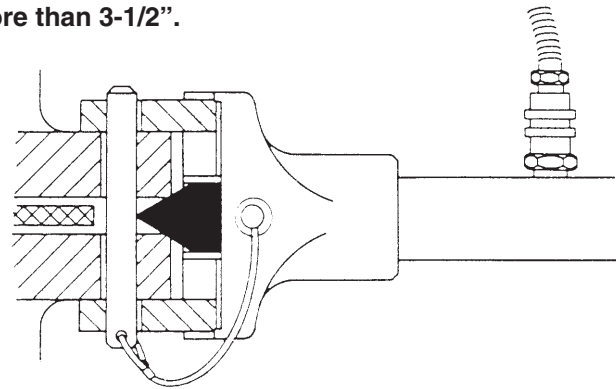

NOTE: More than one Flange Spreader may be connected to one pumping unit if it is necessary to separate the flange equally.

## OPTIONAL CATALOG ACCESSORIES

**Wide Flange Openings:** It is possible that the 60° blade (provided) could come in contact with the pin assembly when attempting a wide flange opening. In this case, a blunt-faced 60° blade with o-ring (#350823) is available.

**Difficult Spreading Situations:** The optional 30° blade with o-ring (#350822) provides more than twice the spreading force of the 60° blade when more force is needed to separate a flange.

## FLANGE SPREADER ASSEMBLY INSTRUCTIONS

1. Apply Loctite #242 and assemble the cylinder into the threads of the flange spreader body.
2. Assemble the blade into the cylinder piston.
3. Thread the set screw (Item #12) through the flange spreader body wall to the groove in the blade and back out one turn.
4. Extend the piston rod until dead ended.
5. Set the distance between the blade radius and the contact point of the pin by threading the cylinder in or out of the flange spreader body.
6. Allow the Loctite to cure for 24 hours before handling.

---

## CYLINDER SPRING AND RETAINER ASSEMBLY

The spring must not extend beyond the threads of the spring retainer on either end. Stretch, clean and lubricate the spring before assembly.

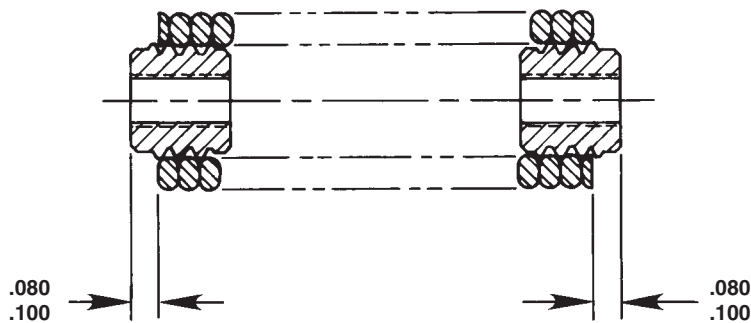

### PARTS LIST

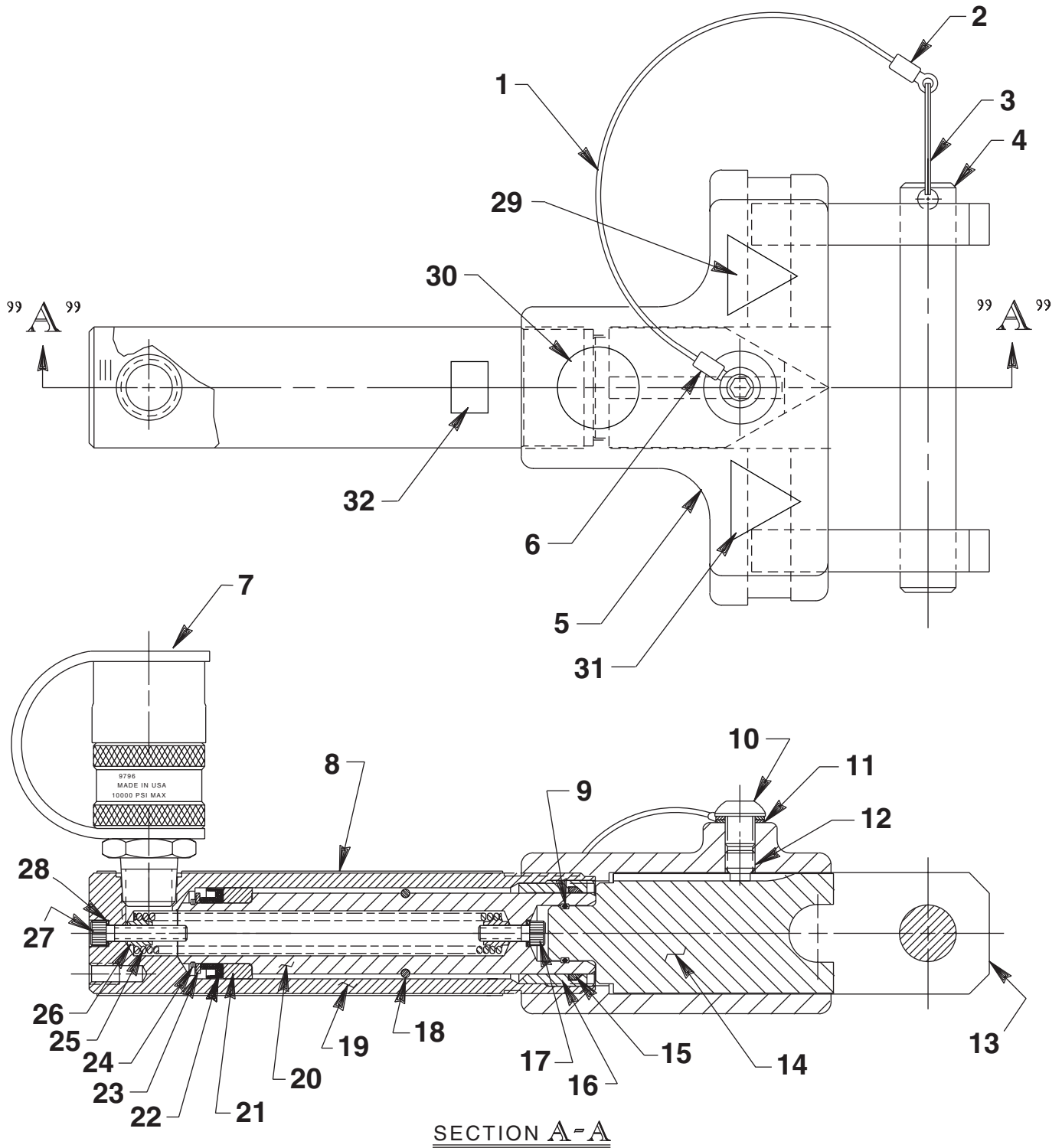

| <b>Item No.</b> | <b>Part No.</b> | <b>No. Req'd</b> | <b>Description</b>   |
|-----------------|-----------------|------------------|--|
| 1               | 251447          | 1.5 ft.          | Aircraft Cable   |
| 2               | 11208           | 1                | Terminal   |
| 3               | 251448          | 1                | Key Ring   |
| 4               | 251444          | 1                | Pin  |
| 5               | 58457           | 1                | Body   |
| 6               | 251449          | 1                | Terminal   |
| 7               | 9796            | 1                | Ram Half Coupler w/Plastic Dust Cap                            |
| 8               | 350844          | 1                | Full Coverage Decal  |
| 9               | 11284           | 1                | O-ring (11/16 x 9/16 x 1/16; Included with Item #14)           |
| 10              | 251445          | 1                | Cap Screw (3/8-16 UNC x 3/8 Lg.)                               |
| 11              | 10259           | 1                | Lockwasher (External tooth)                                    |
| 12              | 251446          | 1                | Set Screw (3/8-16 UNC x 3/8 Lg.)                               |
| 13              | 350846          | 2                | Adjustable Jaw   |
| 14              | 350845          | 1                | Standard 60° Sharp Blade (Includes Item #9)                    |
| 15              | *201424         | 1                | Rod Wiper  |
| 16              | 305065          | 1                | Retainer Nut (Torque to 40/80 in. lbs.)                        |
| 17              | 15122           | 1                | Cap Screw (#10-32 UNF X 5/8 Lg.; Torque to 50/60 in. lbs.)     |
| 18              | 16072           | 1                | Retaining Ring   |
| 19              | 42168           | 1                | Cylinder Body (See assembly instructions on back sheet 2 of 3) |
| 20              | 350843          | 1                | Piston Rod   |
| 21              | 201377          | 1                | Piston Head (Assemble with groove toward shoulder.)            |
| 22              | *210391         | 1                | U-cup  |
| 23              | 201373          | 1                | Retainer Washer  |
| 24              | *13653          | 1                | Retaining Ring   |
| 25              | 201422          | 1                | Extension Spring (See detail on back sheet 2 of 3)             |
| 26              | 201372          | 2                | Spring Retainer (See detail on back sheet 2 of 3)              |
| 27              | 16071           | 1                | Cap Screw (#10-32 UNF X 1" Lg.; Torque to 50/60 in. lbs.)      |
| 28              | *14319          | 2                | Copper Washer (5/16 X 3/16 X 1/32)                             |
| 29              | 253645          | 1                | Warning Decal  |
| 30              | 253584          | 1                | Pictorial Decal (Read Instructions)                            |
| 31              | 251057          | 1                | Warning Decal  |
| 32              | 350988          | 1                | CE Decal   |

**PARTS INCLUDED BUT NOT SHOWN**

213083 1 Tube of Lubriplate Lubricant

**OPTIONAL CATALOG ACCESSORIES**

350823 1 Blunt End Blade  
 350822 1 30° Sharp Blade

Part numbers marked with an asterisk (\*) are contained in Standard Repair Kit No. 300404.

Note: Shaded areas reflect last revision(s) made to this form.