

PULLER ATTACHMENTS

Bearing & Pulley



USED WHERE SPACE DOES NOT PERMIT HOOKING PULLER JAWS DIRECTLY ON PART TO BE PULLED.

- “Knife-like” edges fit behind bearings and other hard-to-grip parts for easy removal, even where clearance is limited.
- Usable with both Lock-Jaw™ jaw type pullers and Bi-Directional™.
- All puller blocks are made from forged alloy steel
- Meets Fed. Spec.: GGG-P-00781-D

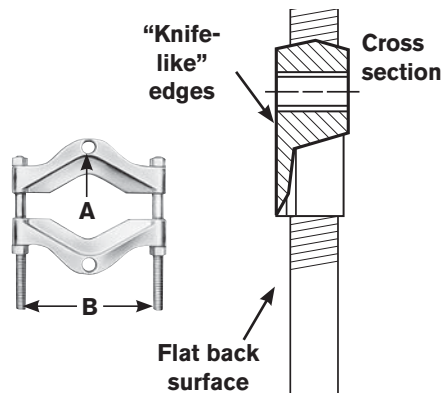

Attachment clamps down into V-groove to distribute load. Use with Lock-Jaw™ pullers or Bi-Directional™ Pullers.



X = Thread of tapped hole in adapter.
Y = Distance between adjusting screws.

Order No.	Max. Spread (in.)	Min. Spread (in.)	A (in.)	B (in.)	Wt.	Application - (Use with Puller Nos.)
1121	15/16"	1/4"	5/16"-18	1 11/16"	12 oz.	1020, 1022, and 1023.
1122	2"	1/8"	3/8"-16	2 7/16"	1 lb., 4 oz.	1024, 1025, 1026, 1027, 7392 and 7393.
1123	4 5/8"	1/2"	5/8"-18	4 3/8"	5 lbs.	1035, 1036, 1037, 1038, and 927.
1124	5 3/4"	1/2"	5/8"-18	6"	12 lbs.	1035, 1040, 1041, 1042, PH172, PPH17, and 938.
1126	8"	5/8"	1"-14	7 1/2"	19 lbs., 12 oz.	1043, and 939.
1127	13 3/8"	3/4"	1"-14	10 1/4"	41 lbs., 12 oz.	939, PH302, and PPH30.
1128	12 7/8"	5"	1 3/4"-12	13"	100 lbs.	PH302*, PH502*, PH553C, and PPH50. (When using 1128 with PPH50, two 8024 adapter are required to connect PPH50 to the puller tees).
1130	9"	1/2"	5/8"-18	6"	12 lbs., 9 oz.	1035, 1040, 1041, 1042, PH172, PPH17, and 938.
V-belt pulley pulling attachments						
679	5 7/8"	1 3/4"	5/8"-18	6"	4 lbs., 4 oz.	1035, 1036, 1037, 1038, and 927.
680	10"	1 5/8"	5/8"-18	10 1/16"	22 lbs., 4 oz.	1039, 1040, 1041, 1042, PH172, PPH30* and 938. (When using 680 with PPH30, two 8012 adapters are required).

Pulling attachment accessory – “Knife-like” edges of attachment fit behind bearings or other parts for easy removal with “Enforcer 55”, even if space does not permit hooking puller jaws directly to part being pulled.

No. 1128 – Spread: 5" to 12 7/8". Wt., 100 lbs.

* Indicates discontinued puller model.

