



# SERVICE PARTS LIST

**BULLETIN NO.**  
**54-40-7040**

SPECIFY CATALOG NO. AND SERIAL NO. WHEN ORDERING PARTS		REVISED BULLETIN	DATE
<b>CORDLESS BAND SAW</b>			Feb. 2009
CATALOG NO. <b>0729-20</b>	STARTING SERIAL NO. <b>A59A</b>	WIRING INSTRUCTION <b>SEE REVERSE SIDE</b>	

**EXAMPLE:**  
Component Parts (Small #) Are Included When Ordering The Assembly (Large #).

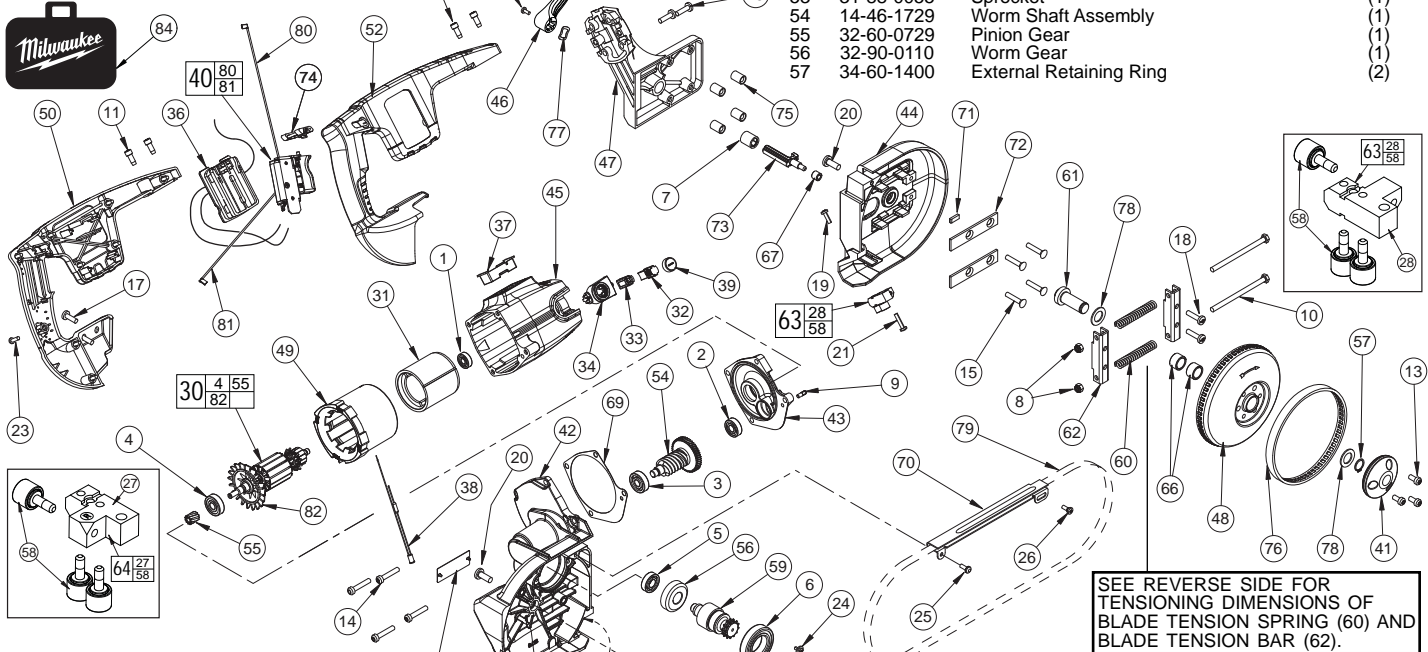

**CAUTION!** When removing armature assembly (30), do not allow armature commutator or commutator end ball bearing to strike brush tubes (33).

**SEE REVERSE SIDE FOR TENSIONING DIMENSIONS OF BLADE TENSION SPRING (60) AND BLADE TENSION BAR (62).**

**FIG. LUBRICATION:**  
42 Place 3 Oz. Type 'G' Grease, 49-08-4140, At Worm Gear Cavity.

FIG.	PART NO.	DESCRIPTION OF PART	NO. REQ.
1	02-04-0851	Ball Bearing	(1)
2	02-04-1020	Ball Bearing	(1)
3	02-04-1030	Ball Bearing	(1)
4	02-04-1050	Ball Bearing	(1)
5	02-04-1210	Ball Bearing	(1)
6	02-04-2700	Ball Bearing	(1)
7	02-50-3235	Needle Bearing	(1)
8	06-57-5000	Flex-Loc Nut	(2)
9	06-65-1155	Groove Pin	(1)
10	06-75-1991	1/4-20 x 4.0 Hex Head Screw	(2)
11	06-75-3270	1/4-20 x .625 Socket Cap Taprite Screw	(4)
12	06-75-4675	3/8 x 1 Socket Head Screw	(1)
13	-----	Screw (*See Special Note Below)	(3)
14	06-82-3060	1/4-20 x 1.313 Fill. Hd. Tapt. T-30 Screw	(4)
15	06-82-3810	1/4-20 x 1.25 Fill. Hd. Tapt. T-27 Screw	(4)
16	06-82-5292	1/4-20 x .875 Taprite T-30 Screw	(4)
17	06-82-5294	1/4-20 x .75 Taprite T-30 Screw	(2)
18	06-82-5298	1/4-20 x 1.00 Taprite T-30 Screw	(2)
19	06-82-5330	#10-32 x .625 Taprite T-25 Screw	(2)
20	06-82-5394	5/16-18 x 13/16 Pan Hd. T-40 Screw	(2)
21	06-82-5574	#10-24 x .875 Taprite T-25 Screw	(2)
22	06-82-7252	#8-32 x .38 Taprite T-20 Screw	(1)
23	06-82-7270	8-16 x .625 Slotted Plastite T-20 Screw	(9)
24	06-82-8842	8-32 x .38 Sit. Tapt. T-20 Screw	(2)
25	06-82-8864	10-24 x 1/2 Pan Hd. Sems T-25 Screw	(4)
26	06-82-9270	10-24 x 1/2 Pan Hd. Tapt. Shld. T-25	(1)
27	42-28-0210	Rear Blade Guide	(1)
28	42-28-0205	Front Blade Guide	(1)
29	12-20-0729	Service Nameplate	(1)
30	16-01-2130	Service Armature	(1)
31	18-01-2000	Service Field	(1)
32	22-18-0729	Carbon Brush Assembly	(2)
33	22-20-0660	Brush Tube	(2)
34	22-20-0729	Brush Tube Housing	(2)
35	22-56-0150	Connector (Not Shown)	(1)
36	22-56-1729	Connector Block Assembly	(1)
37	23-16-1340	Insulator	(1)
38	23-28-0140	LED Wire Assembly	(1)
39	23-44-0220	Brush Cap Screw	(2)
40	23-66-0721	Switch Assembly	(1)
41	31-15-1220	Blade Pulley Cover	(2)
42	28-14-0729	Gearcase	(1)
43	28-28-1697	Diaphragm	(1)
44	28-41-0920	Front Pulley Guard	(1)
45	28-50-0729	Motor Housing	(1)
46	31-52-0032	Blade Release Lever	(1)
47	28-90-0200	Pulley Support	(1)
48	28-95-0120	Blade Pulley	(2)
49	31-05-0129	Baffle / Spacer	(1)
50	31-44-0129	Left Handle Half	(1)

FIG.	PART NO.	DESCRIPTION OF PART	NO. REQ.
51	31-44-0330	Front Handle	(1)
52	31-44-0729	Right Handle Half	(1)
53	31-88-0055	Sprocket	(1)
54	14-46-1729	Worm Shaft Assembly	(1)
55	32-60-0729	Pinion Gear	(1)
56	32-90-0110	Worm Gear	(1)
57	34-60-1400	External Retaining Ring	(2)

FIG.	PART NO.	DESCRIPTION OF PART	NO. REQ.
58	02-25-0260	Cam Follower	(6)
59	36-66-0525	Worm Gear Shaft	(1)
60	40-50-0710	Blade Tension Spring	(2)
61	42-12-0070	Pulley Axle	(2)
62	42-18-0190	Blade Tension Bar	(2)
63	42-28-0206	Front Blade Guide Assembly	(1)
64	42-28-0211	Rear Blade Guide Assembly	(1)
65	42-38-0042	Work Piece Bumper	(1)
66	42-40-0580	Sleeve Bearing	(4)
67	42-40-1010	Bronze Bushing	(1)
68	42-60-0195	Double Strand Roller Chain	(1)
69	43-44-1130	Gasket	(1)
70	43-54-0245	Blade Guard	(1)
71	44-52-0120	Blade Backing Pad	(1)
72	44-66-0550	Guard Retaining Plate	(2)
73	45-08-0172	Blade Release Shaft	(1)
74	45-24-0129	Hi/Lo Shuttle	(1)
75	45-36-0720	Retaining Plate Spacer	(4)
76	45-69-0010	Pulley Tire	(2)
77	45-88-7105	Wave Spring Washer	(1)
78	45-88-7165	Pulley Hub Washer	(4)
79	-----	Blade (Select from catalog)	(1)
80	23-94-0390	Leadwire Assembly - Black	(1)
81	23-94-0380	Leadwire Assembly - Red	(1)
82	22-84-0531	Fan Assembly	(1)
83	-----	Screw (*See Special Note Below)	(3)
84	42-55-0729	Carrying Case, Optional	(1)

**\*SPECIAL NOTE:**  
Use the following screws for tools with **metal** blade pulley covers (41):  
13 06-82-3024 1/4-20 x 1/2" Fil. Hd. Taptite T-30 Screw (3)  
83 06-82-3060 1/4-20 x 1-5/16" Fil. Hd. Taptite T-30 Screw (3)  
Use the following screws for tools with **plastic** blade pulley covers (41):  
13 06-82-5338 1/4-20 x 1/2" Pan Hd. Taptite T-30 Screw (3)  
83 06-82-2365 1/4-20 x 1-5/16" Pan Hd. T-30 Screw (3)

**MILWAUKEE ELECTRIC TOOL CORPORATION**  
13135 W. LISBON RD., BROOKFIELD, WI 53005  
Drwg. 4

**FIG. NOTES:**

- 4,30 Press bearing .640 ±.005 from fan end of armature shaft.
- 50,30 Press pinion flush ±.005 onto fan end of armature shaft.
- 7,47 Press needle bearing flush to bottom of pulley support. Manufactures ID must face towards the front pulley guard.
- 9,43,44 Press groove pin flush to .010 sub flush to the face of diaphragm, adjacent to motor housing.
- 20,61 Apply Loctite® adhesive 242 or equivalent to threads of screw prior to securing axle shaft.
- 33,34 Orient brush tube in brush holder with terminal tab in open slot.
- 48,66 Insert sleeve bearings flush ±.01" to outside of front and rear blade pulleys. A gap remains between bearings in the center of the pulleys.
- 31,49 Assemble field, with large chamfer as leading end, into baffle/spacer.
- 38,49 Press LED flush to baffle/spacer outside surface by hand.
- 31,49 Press field into baffle/spacer, seating to interior tab surface.
- 45,49 Press baffle/spacer into motor housing, seating to machined interior pads.
- 60,62 Set tension dimensions between the two blade tension bars, as illustrated.

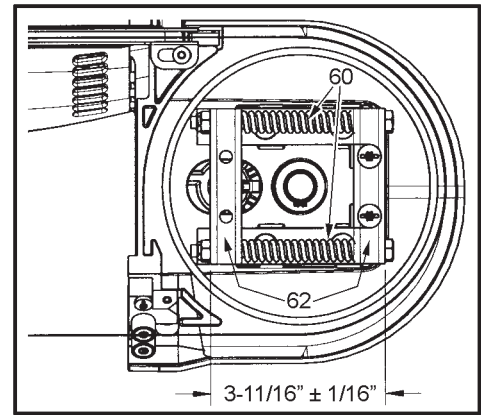

**WIRING INSTRUCTIONS**

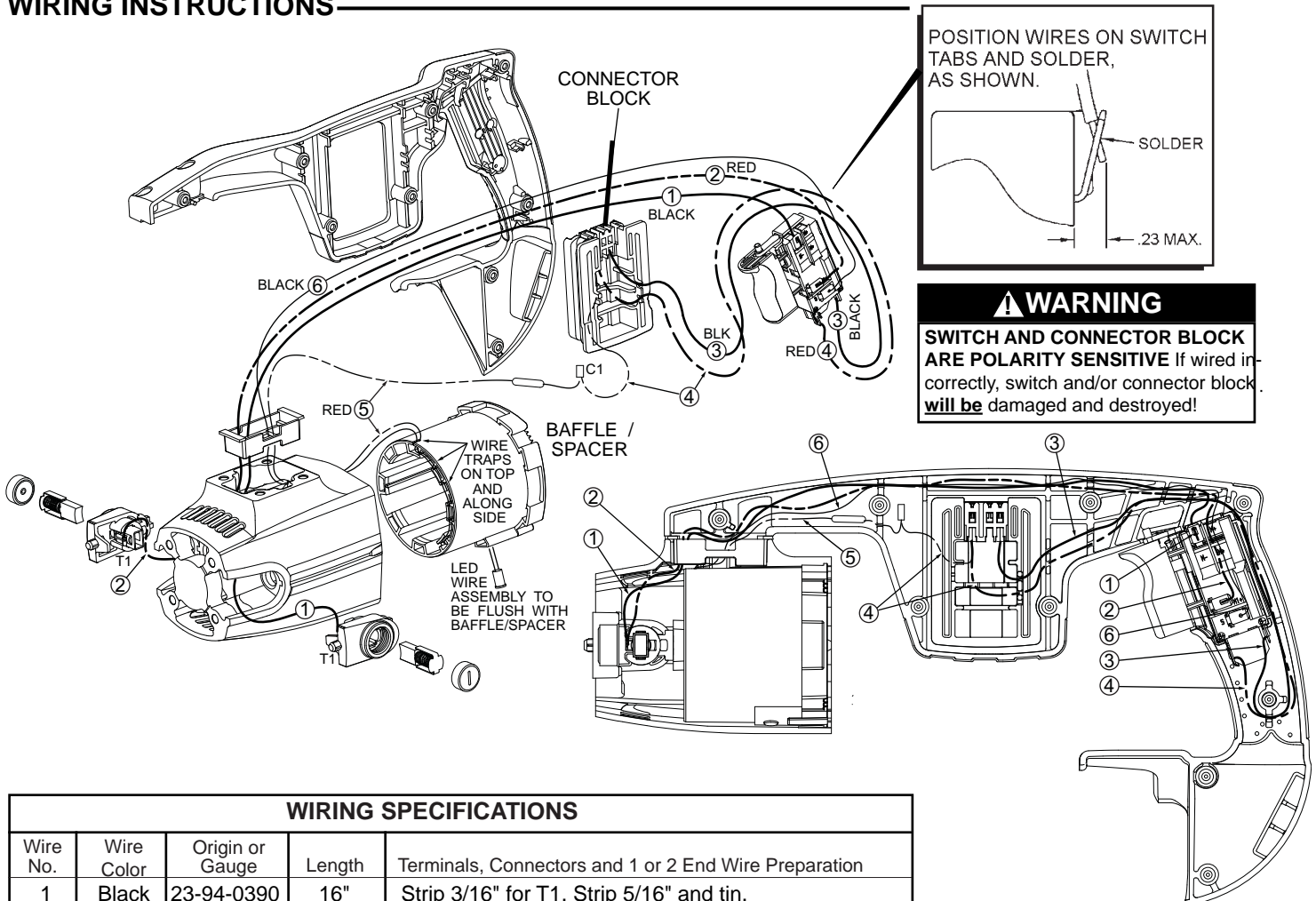

**WIRING SPECIFICATIONS**

Wire No.	Wire Color	Origin or Gauge	Length	Terminals, Connectors and 1 or 2 End Wire Preparation
1	Black	23-94-0390	16"	Strip 3/16" for T1. Strip 5/16" and tin.
2	Red	23-94-0380	18"	Strip 3/16" for T1. Strip 5/16" and tin.
3	Black	22-56-1729	----	Component of the connector block assembly.
4	Red	22-56-1729	----	Component of the connector block assembly.
5	Red	23-28-0140	----	Component of the LED wire assembly.
6	Black	23-28-0140	----	Component of the LED wire assembly.

**BULK LEAD WIRE - BULLETIN NO. 58-01-0003**

**TERMINAL DESCRIP-**

Code	Part No.	Qty.
T1	23-74-0750	2
C1	22-56-0150	1