



ANSI Z359.14 Class A/B
Class A: Arrest Distance
Class B: Arresting Force

ANSI Z359.14 Class B
Class B: Arrest Distance
Class B: Arresting Force





OSHA 1926.502



OSHA 1910.140

Nano-Lok SELF-RETRACTING DEVICE

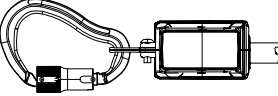
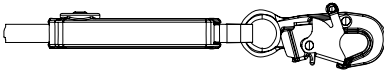
INSTRUCTION MANUAL 5908381 Rev. B

Fall Protection

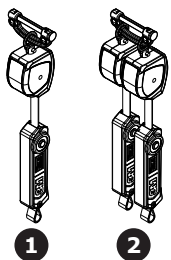
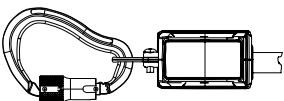
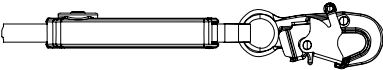
 		Z359.14 Class A/B	Z359.14 Class B	 																			x 1		
				None	2000025	2000112	2000159	2109193	3100084	3100197	9502116	3100108	3100196	2000023	2000114	2000209	2000210	2000214	2109193	9502058	9502116		9502195	9505254	ANSI
3101202	1	✓			1																		6 ft (1.8 m)	310 lbs (140 kg)	420 lbs (190 kg)
3101203	1	✓																					6 ft (1.8 m)	310 lbs (140 kg)	420 lbs (190 kg)
3101204	1	✓	1									1											6 ft (1.8 m)	310 lbs (140 kg)	420 lbs (190 kg)
3101210	1	✓	1																			1	6 ft (1.8 m)	310 lbs (140 kg)	420 lbs (190 kg)
3101211	1	✓	1									1											6 ft (1.8 m)	310 lbs (140 kg)	420 lbs (190 kg)
3101214	1	✓		1																		1	6 ft (1.8 m)	310 lbs (140 kg)	420 lbs (190 kg)
3101215	1	✓			1																	1	6 ft (1.8 m)	310 lbs (140 kg)	420 lbs (190 kg)
3101216	1	✓				1																1	6 ft (1.8 m)	310 lbs (140 kg)	420 lbs (190 kg)
3101217	1	✓				1																1	6 ft (1.8 m)	310 lbs (140 kg)	420 lbs (190 kg)
3101218	1	✓																				1	6 ft (1.8 m)	310 lbs (140 kg)	420 lbs (190 kg)
3101219	1	✓																				1	6 ft (1.8 m)	310 lbs (140 kg)	420 lbs (190 kg)
3101225	1	✓										1											6 ft (1.8 m)	310 lbs (140 kg)	420 lbs (190 kg)
3101226	1	✓										1											6 ft (1.8 m)	310 lbs (140 kg)	420 lbs (190 kg)
3101227	1	✓																				1	6 ft (1.8 m)	310 lbs (140 kg)	420 lbs (190 kg)
3101228	1	✓																				1	6 ft (1.8 m)	310 lbs (140 kg)	420 lbs (190 kg)
3101229	1	✓																				1	6 ft (1.8 m)	310 lbs (140 kg)	420 lbs (190 kg)
3101235	1	✓																				1	6 ft (1.8 m)	310 lbs (140 kg)	420 lbs (190 kg)
3101236	1	✓																				1	6 ft (1.8 m)	310 lbs (140 kg)	420 lbs (190 kg)
3101239	1	✓																				1	6 ft (1.8 m)	310 lbs (140 kg)	420 lbs (190 kg)
3101240	1	✓																				1	6 ft (1.8 m)	310 lbs (140 kg)	420 lbs (190 kg)
3101241	1	✓																				1	6 ft (1.8 m)	310 lbs (140 kg)	420 lbs (190 kg)
3101250	1	✓																				1	6 ft (1.8 m)	310 lbs (140 kg)	420 lbs (190 kg)
3101251	1	✓																				1	6 ft (1.8 m)	310 lbs (140 kg)	420 lbs (190 kg)
3101252	1	✓																				1	6 ft (1.8 m)	310 lbs (140 kg)	420 lbs (190 kg)

		Z359.14 Class A/B Z359.14 Class B																				 x 1	
1	2		1	2	3	4	5	6	7	8	9	10	11	12	13	14	15	16	17	18		ANSI	OSHA
3101253	1	✓						1											1	6 ft (1.8 m)	310 lbs (140 kg)	420 lbs (190 kg)	
3101254	1	✓	1															1		6 ft (1.8 m)	310 lbs (140 kg)	420 lbs (190 kg)	
3101272	2	✓			1														2	7 ft (1.8 m)	311 lbs (140 kg)	421 lbs (190 kg)	
3101274	2	✓			1														2	8 ft (1.8 m)	312 lbs (140 kg)	422 lbs (190 kg)	
3101275	2	✓						1				2								6 ft (1.8 m)	310 lbs (140 kg)	420 lbs (190 kg)	
3101276	2	✓						1											2	6 ft (1.8 m)	310 lbs (140 kg)	420 lbs (190 kg)	
3101277	2	✓						1									2			6 ft (1.8 m)	310 lbs (140 kg)	420 lbs (190 kg)	
3101278	2	✓						1											2	6 ft (1.8 m)	310 lbs (140 kg)	420 lbs (190 kg)	
3101279	2	✓						1										2		6 ft (1.8 m)	310 lbs (140 kg)	420 lbs (190 kg)	
3101280	2	✓						1										2		6 ft (1.8 m)	310 lbs (140 kg)	420 lbs (190 kg)	
3101299	2	✓						1				2								6 ft (1.8 m)	310 lbs (140 kg)	420 lbs (190 kg)	
3101344	1	✓						1							1					6 ft (1.8 m)	310 lbs (140 kg)	420 lbs (190 kg)	
3101357	1	✓	1												1					6 ft (1.8 m)	310 lbs (140 kg)	420 lbs (190 kg)	
3101468	1	✓						1						1						6 ft (1.8 m)	310 lbs (140 kg)	420 lbs (190 kg)	
3101469	1	✓		1										1						6 ft (1.8 m)	310 lbs (140 kg)	420 lbs (190 kg)	
3101471	2	✓						1												6 ft (1.8 m)	310 lbs (140 kg)	420 lbs (190 kg)	
3101472	2	✓				1														6 ft (1.8 m)	310 lbs (140 kg)	420 lbs (190 kg)	
3101473	2	✓						1						2						6 ft (1.8 m)	310 lbs (140 kg)	420 lbs (190 kg)	
3101663	2	✓						1								2				6 ft (1.8 m)	310 lbs (140 kg)	420 lbs (190 kg)	
3101664	2	✓				1										2				6 ft (1.8 m)	310 lbs (140 kg)	420 lbs (190 kg)	
3101666	1	✓						1								1				6 ft (1.8 m)	310 lbs (140 kg)	420 lbs (190 kg)	
3101673	1	✓	1																1	6 ft (1.8 m)	310 lbs (140 kg)	420 lbs (190 kg)	
3101701	1	✓						1				1								6 ft (1.8 m)	310 lbs (140 kg)	420 lbs (190 kg)	
3101702	1	✓						1										1		6 ft (1.8 m)	310 lbs (140 kg)	420 lbs (190 kg)	
3101703	1	✓						1											1	6 ft (1.8 m)	310 lbs (140 kg)	420 lbs (190 kg)	
3101704	1	✓						1										1		6 ft (1.8 m)	310 lbs (140 kg)	420 lbs (190 kg)	
3101705	2	✓						1										2		6 ft (1.8 m)	310 lbs (140 kg)	420 lbs (190 kg)	
3101706	2	✓						1										2		6 ft (1.8 m)	310 lbs (140 kg)	420 lbs (190 kg)	
3101707	2	✓						1						2						6 ft (1.8 m)	310 lbs (140 kg)	420 lbs (190 kg)	

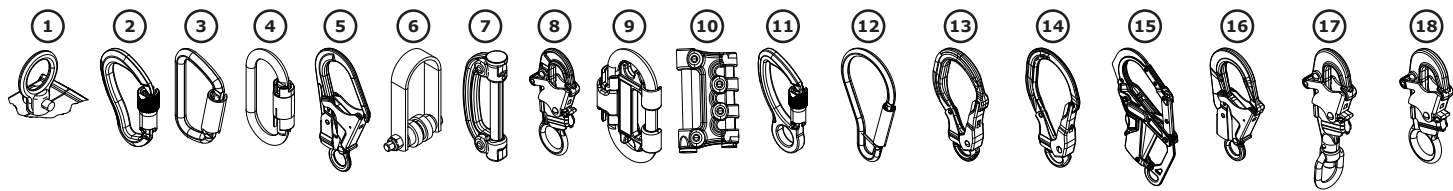

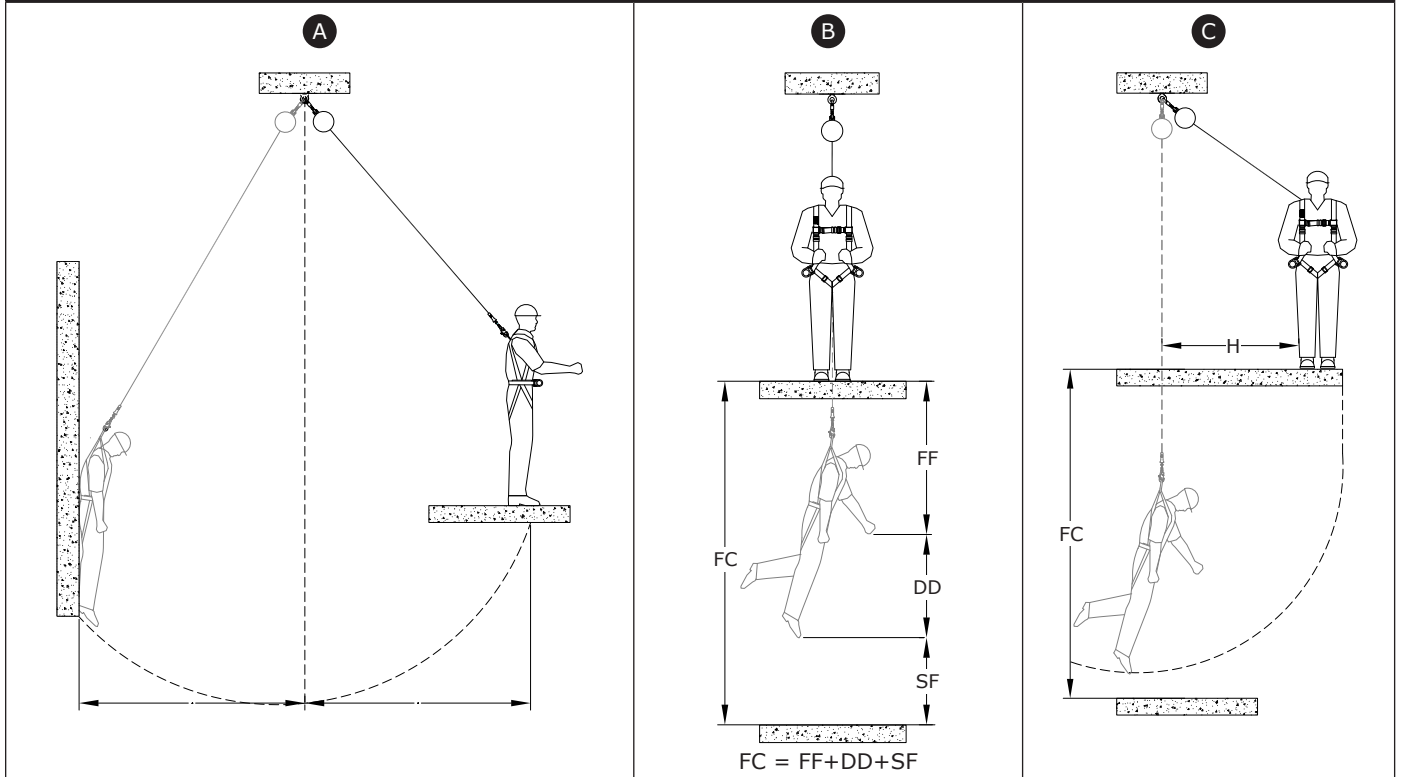
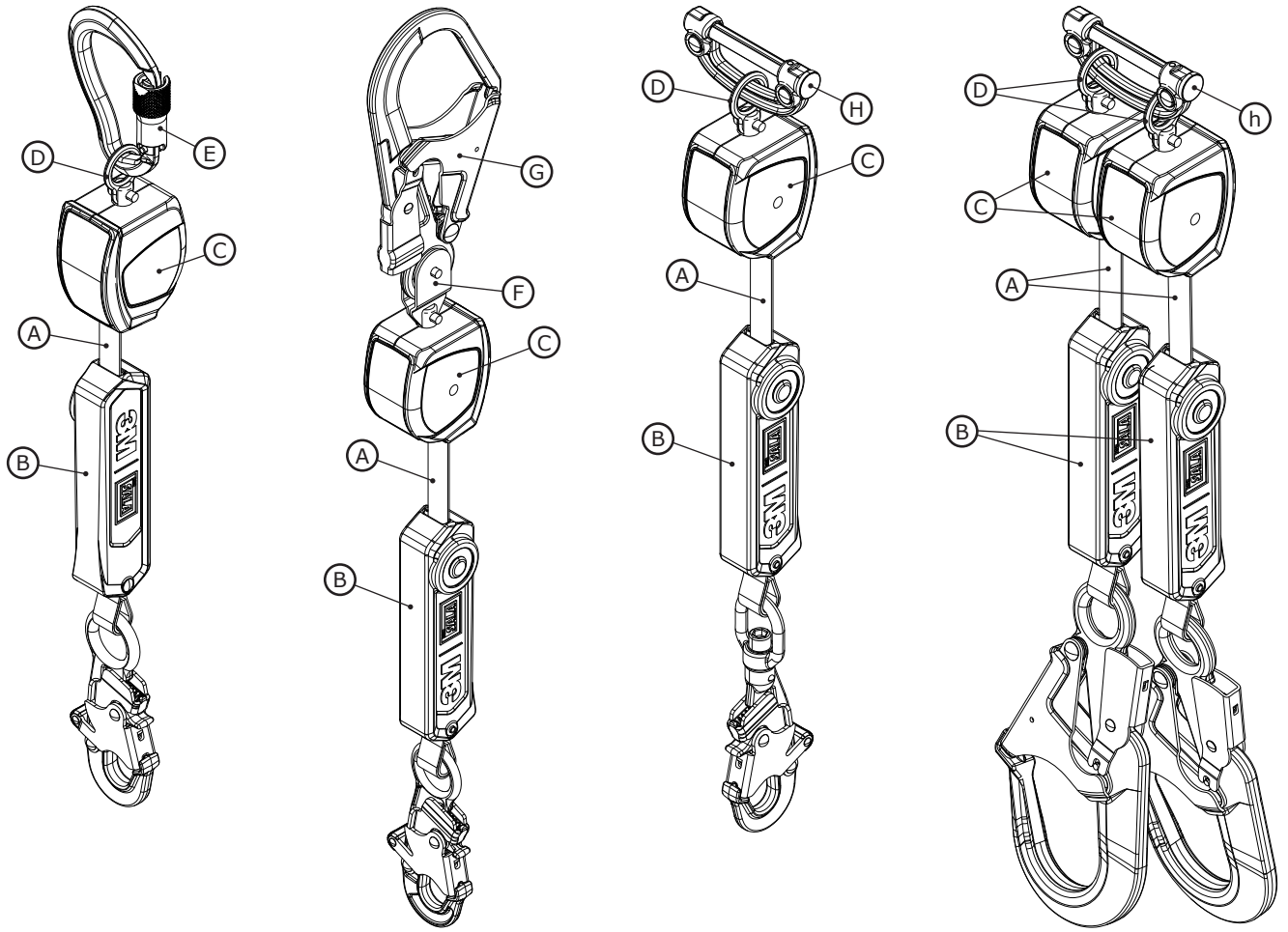

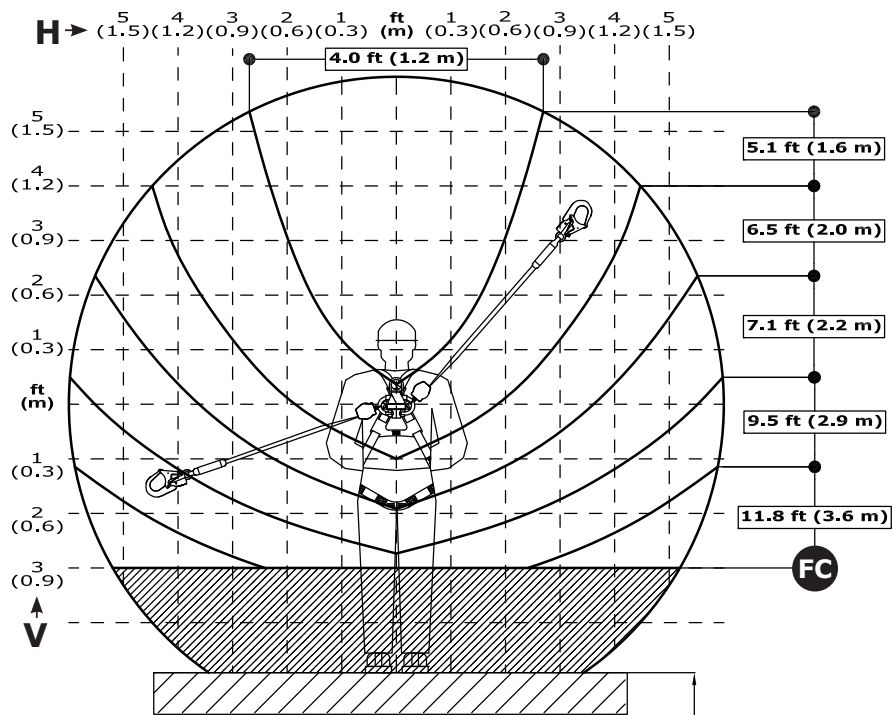



Class A/B

 **x 1**

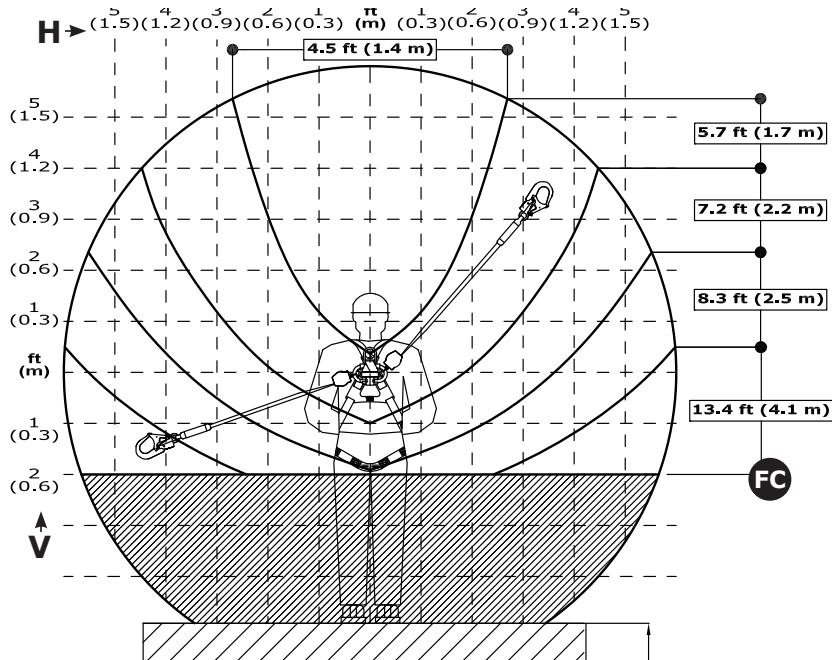
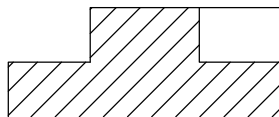
130 lbs - 310 lbs





Class A/B

 **x 1**

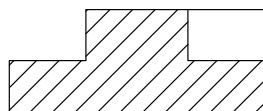
310 lbs - 420 lbs

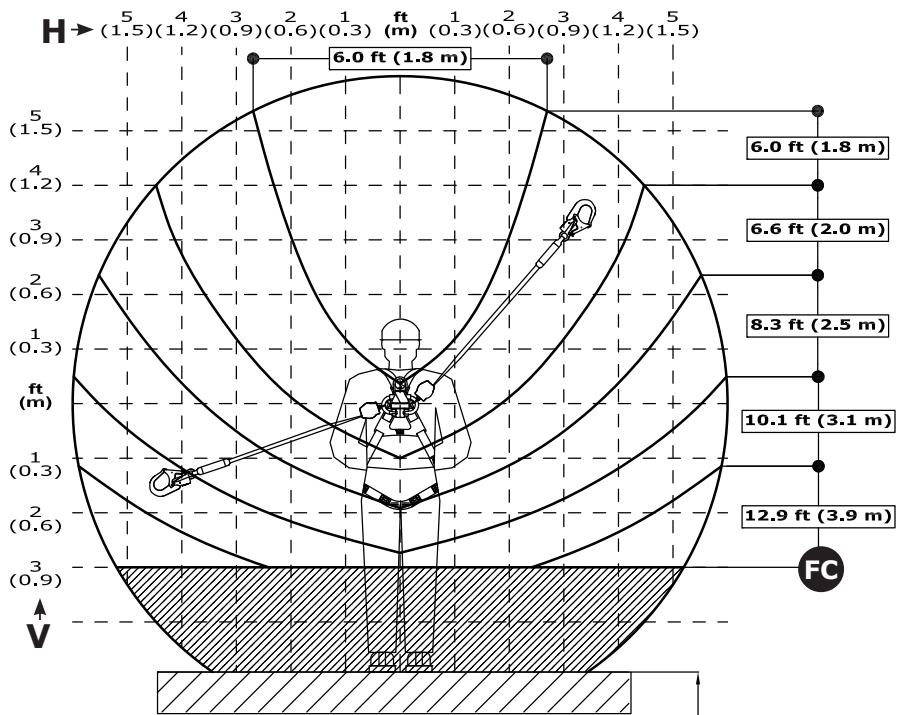



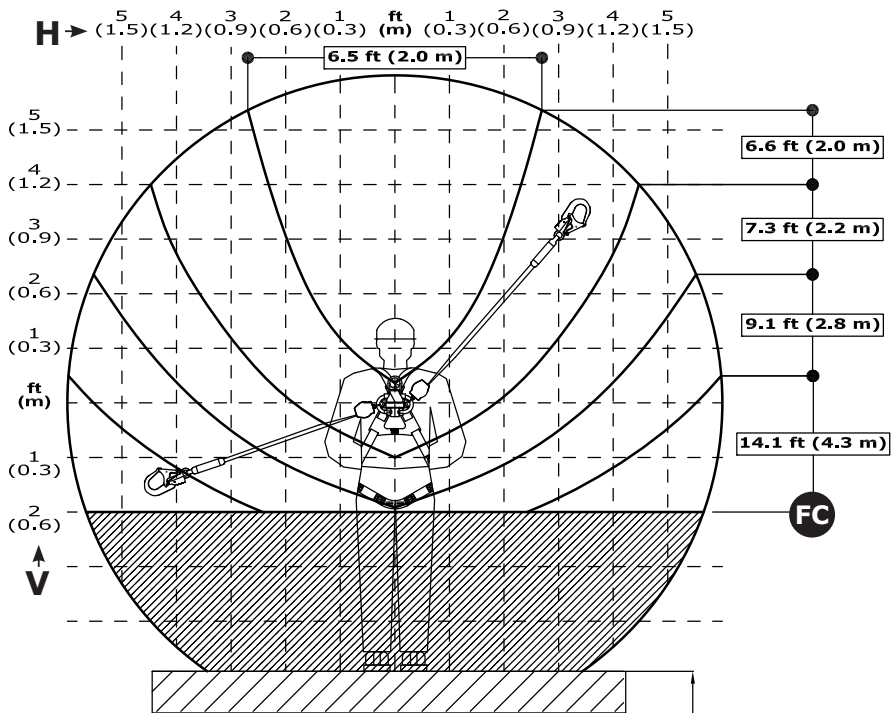
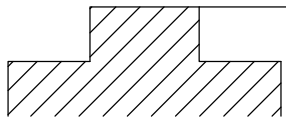

Class B
 x 1
 130 lbs - 310 lbs

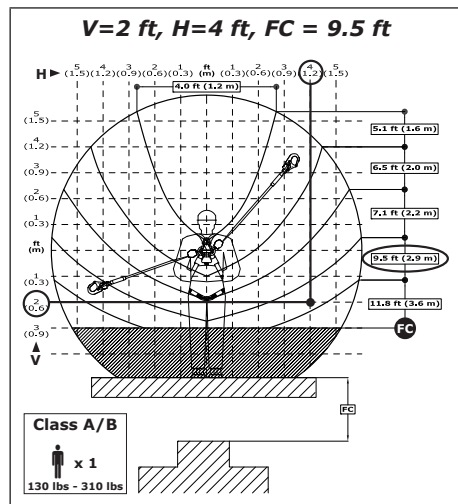
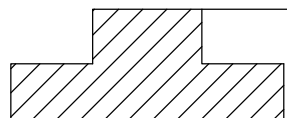

Class B
 x 1
 310 lbs - 420 lbs



Class A/B
 x 1
 130 lbs - 310 lbs

5

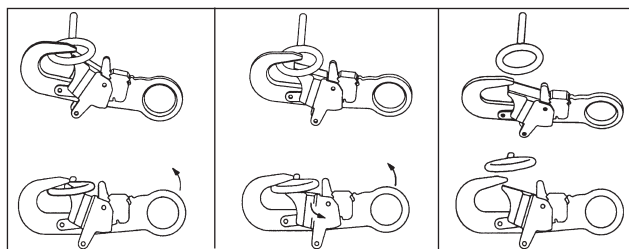

A

B

C

6

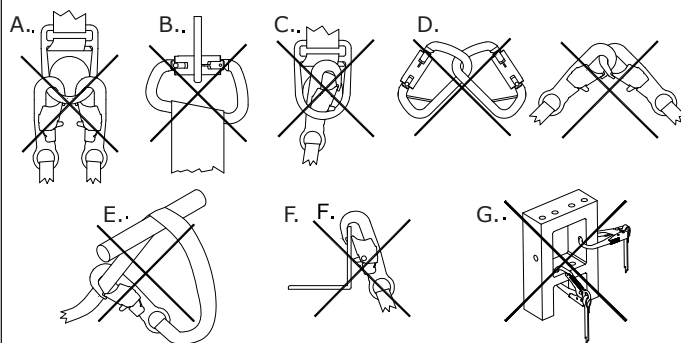

7

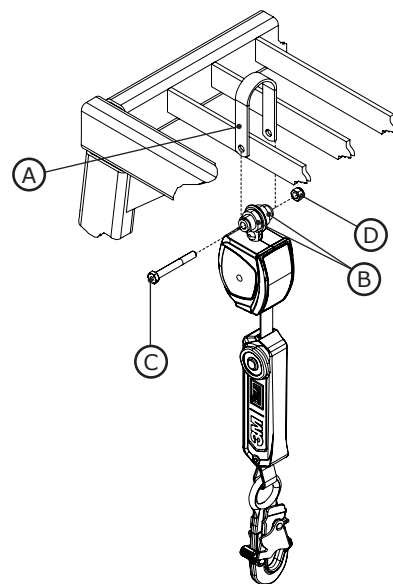
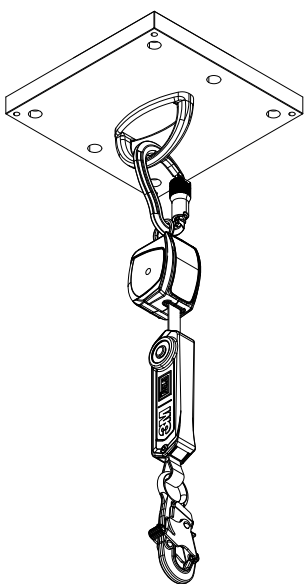
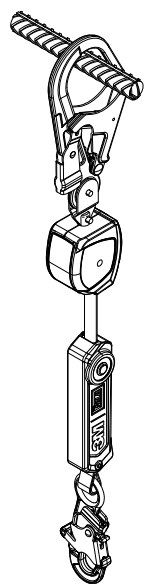

8

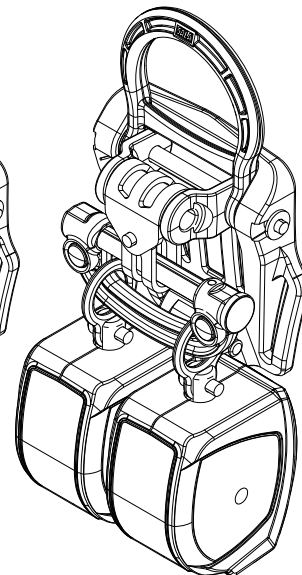
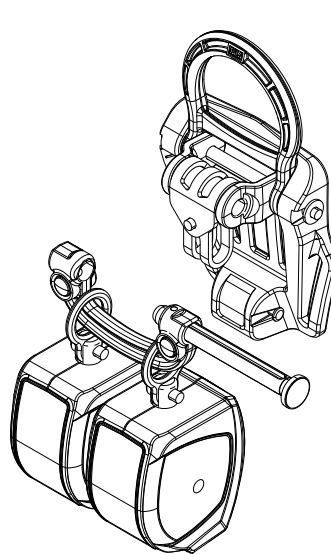
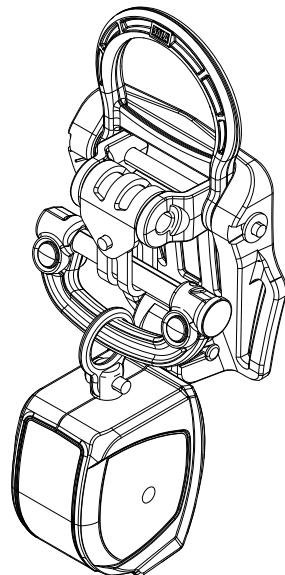
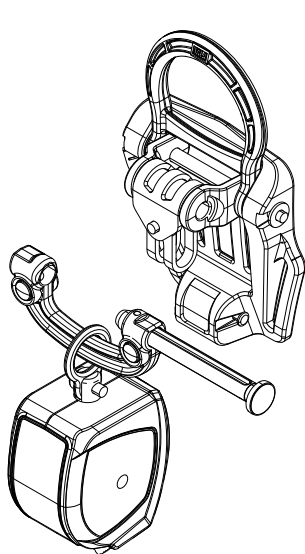

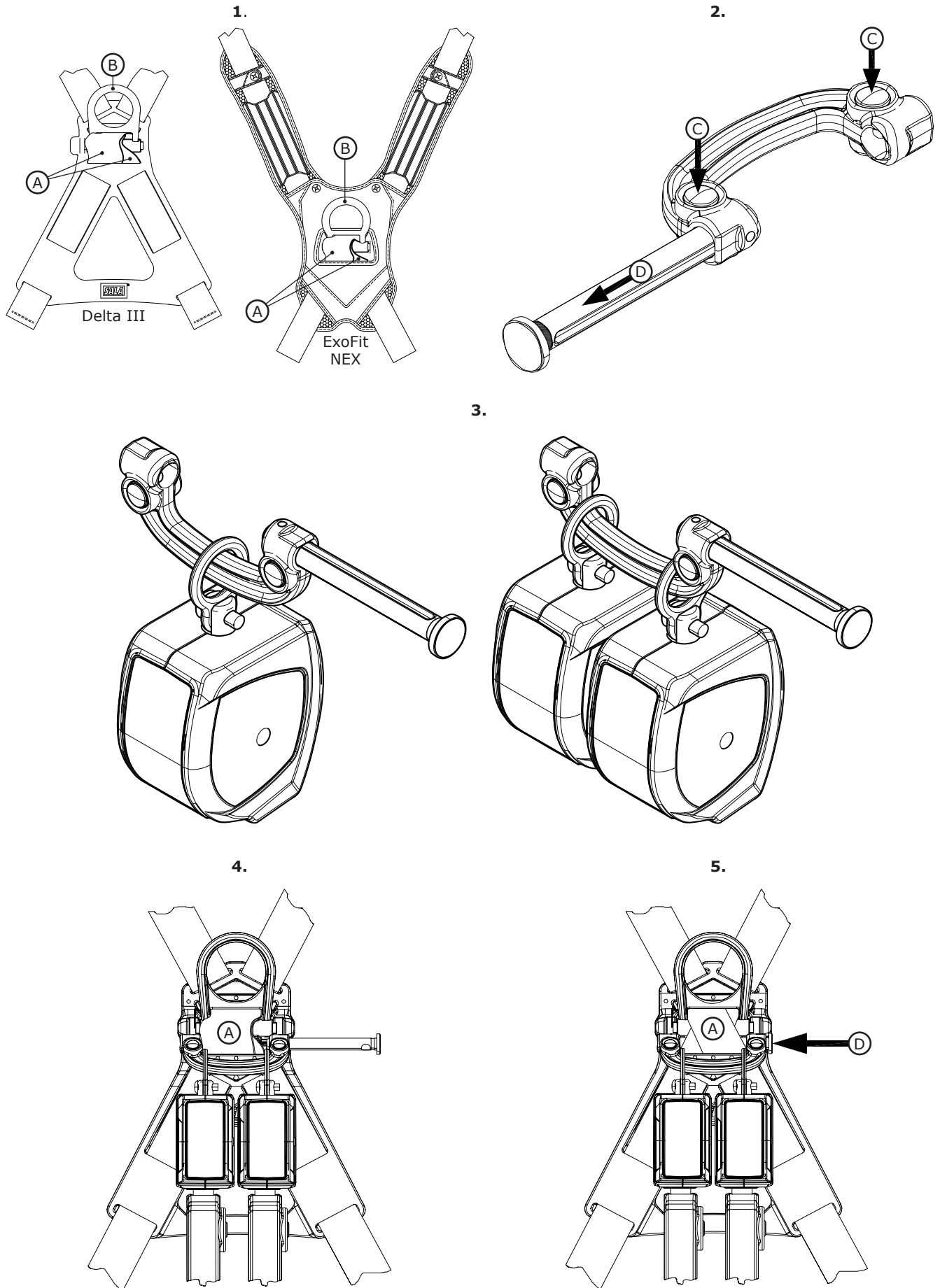

1.

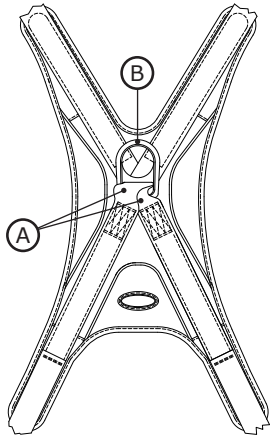

2.

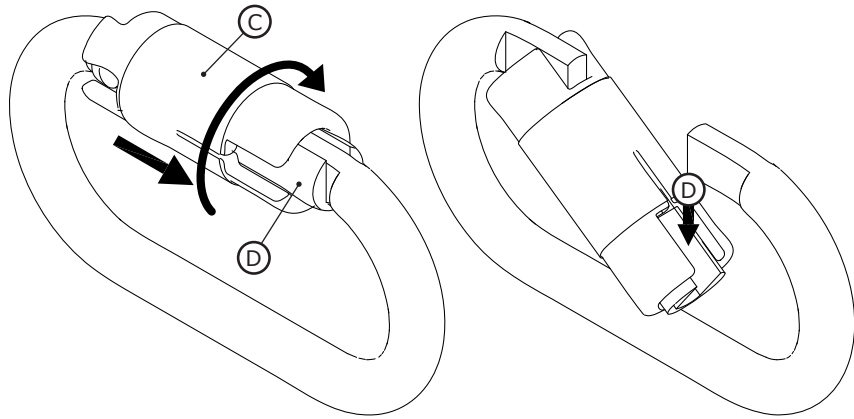

3.

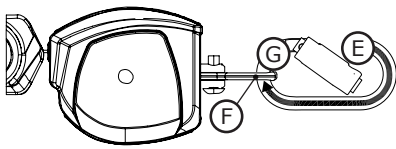

4.

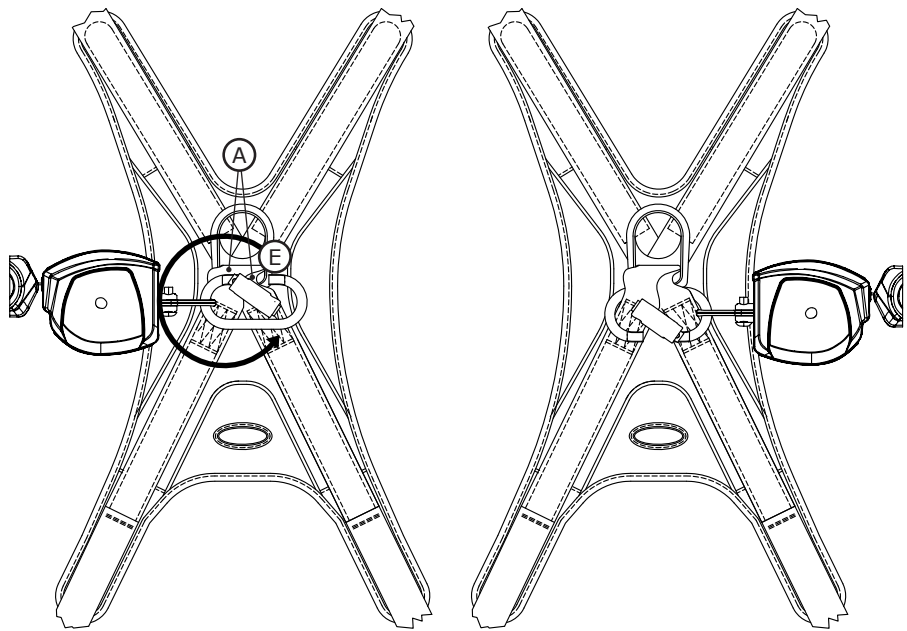

5.

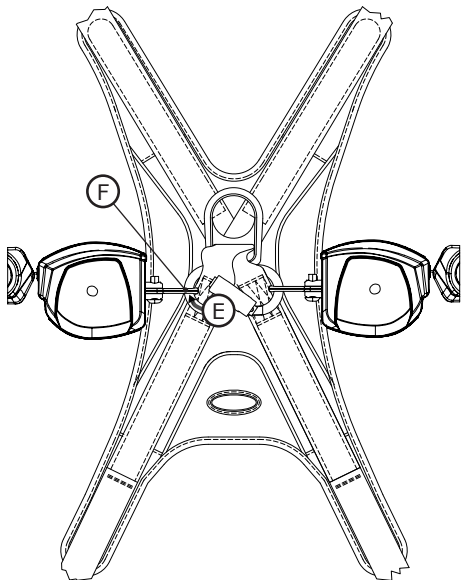

6.

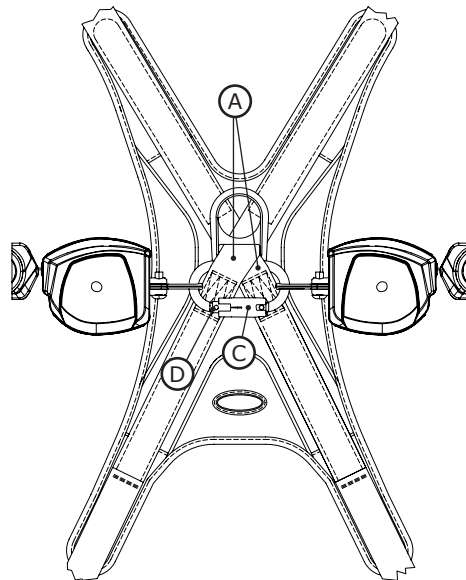

1.

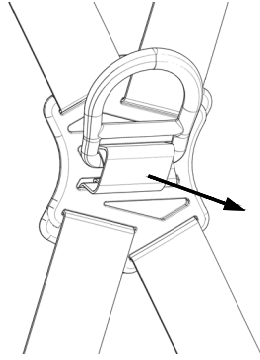

2.

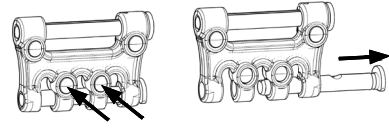

3.

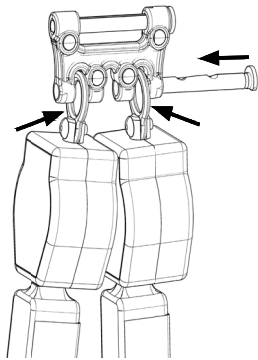

4.

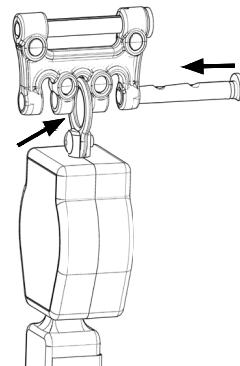

5.

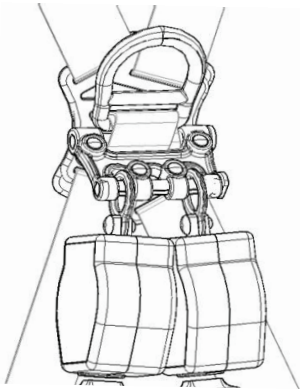

6.

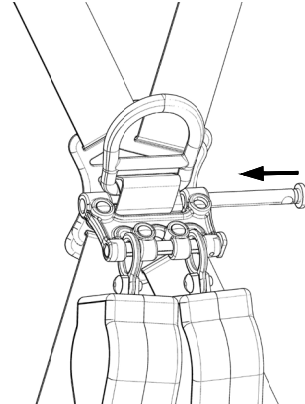

7.

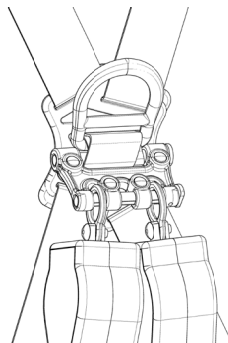

1.

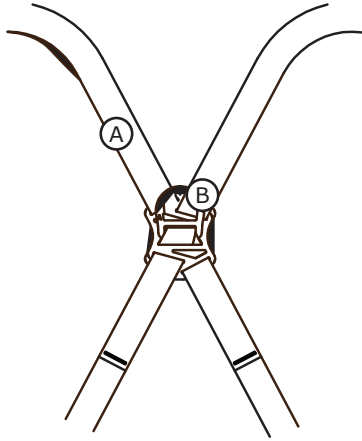

2.

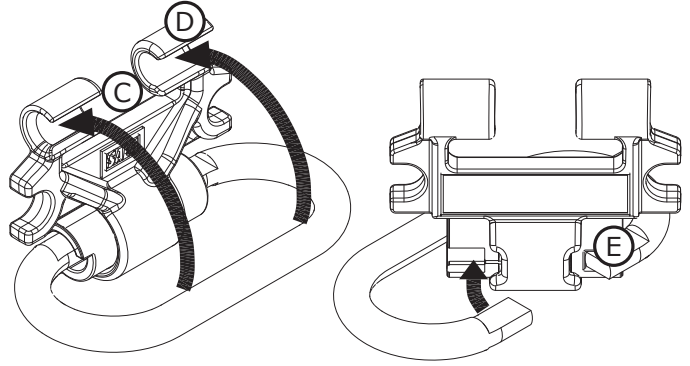

3.

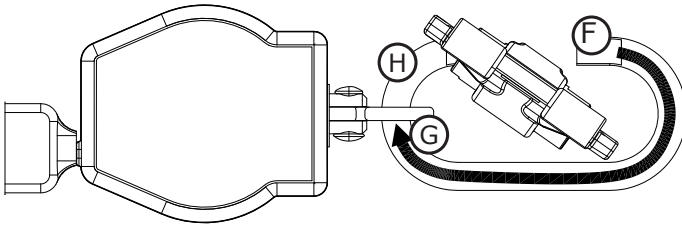

4.

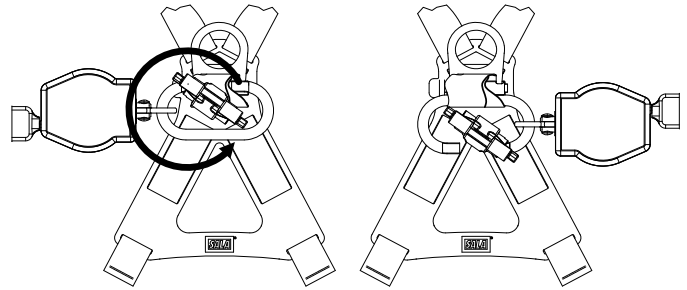

5.

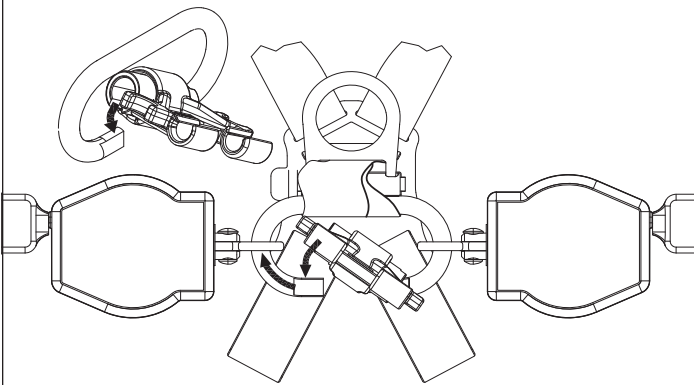

6.

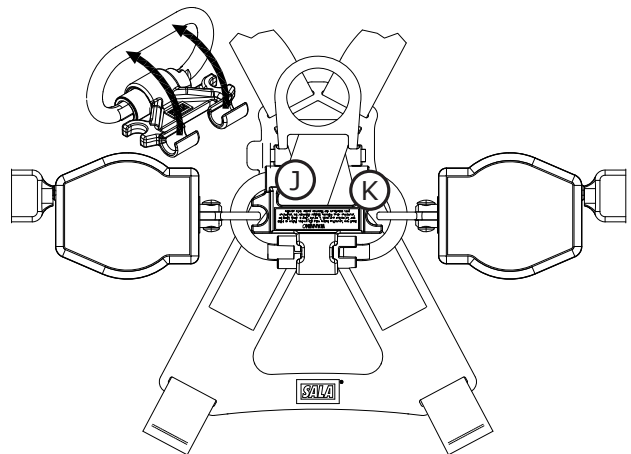

13

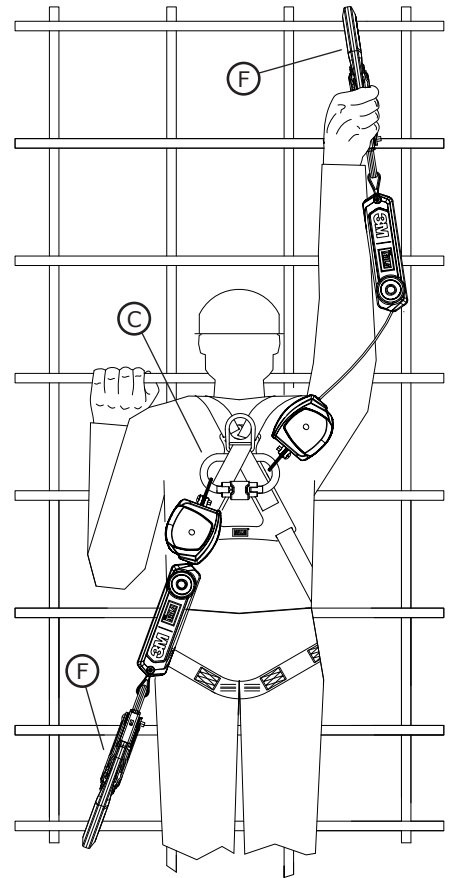
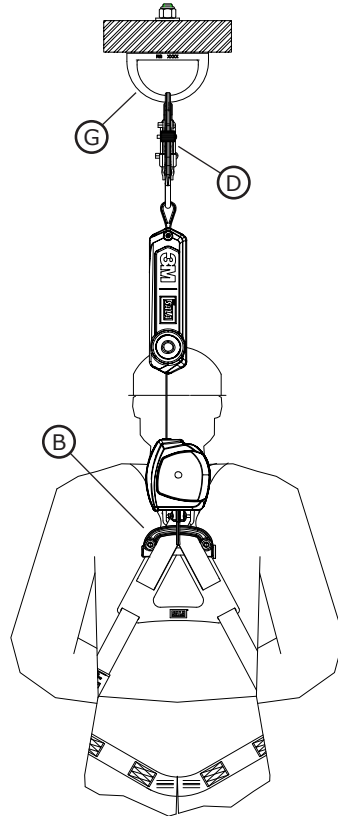
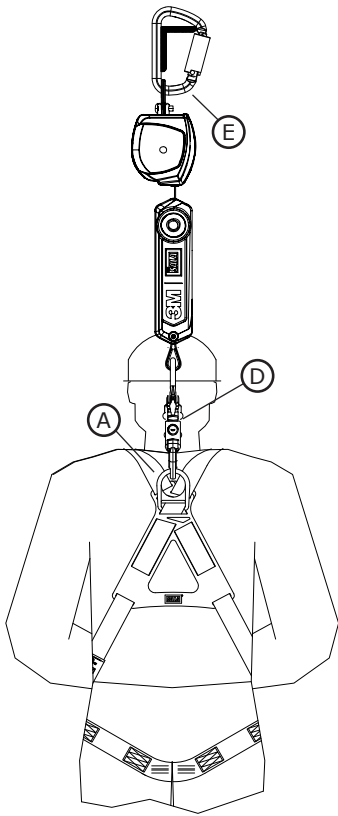

14

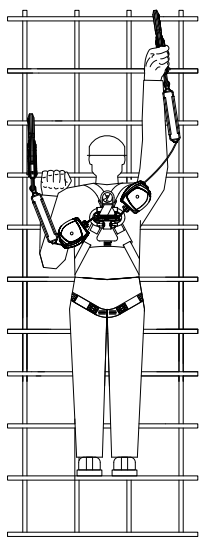

15

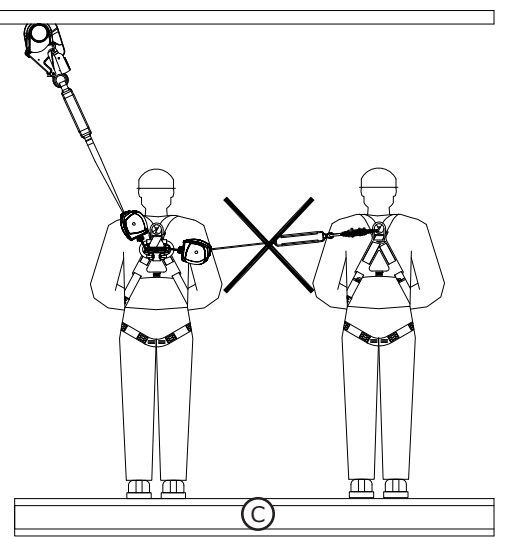
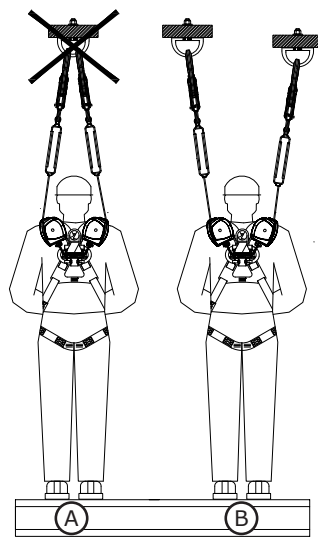

16

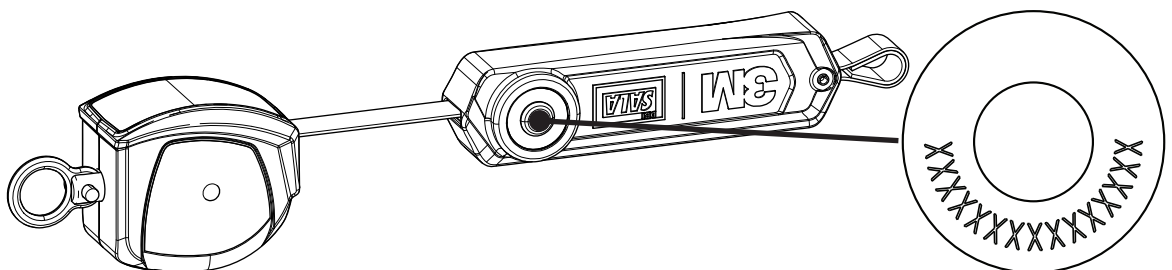

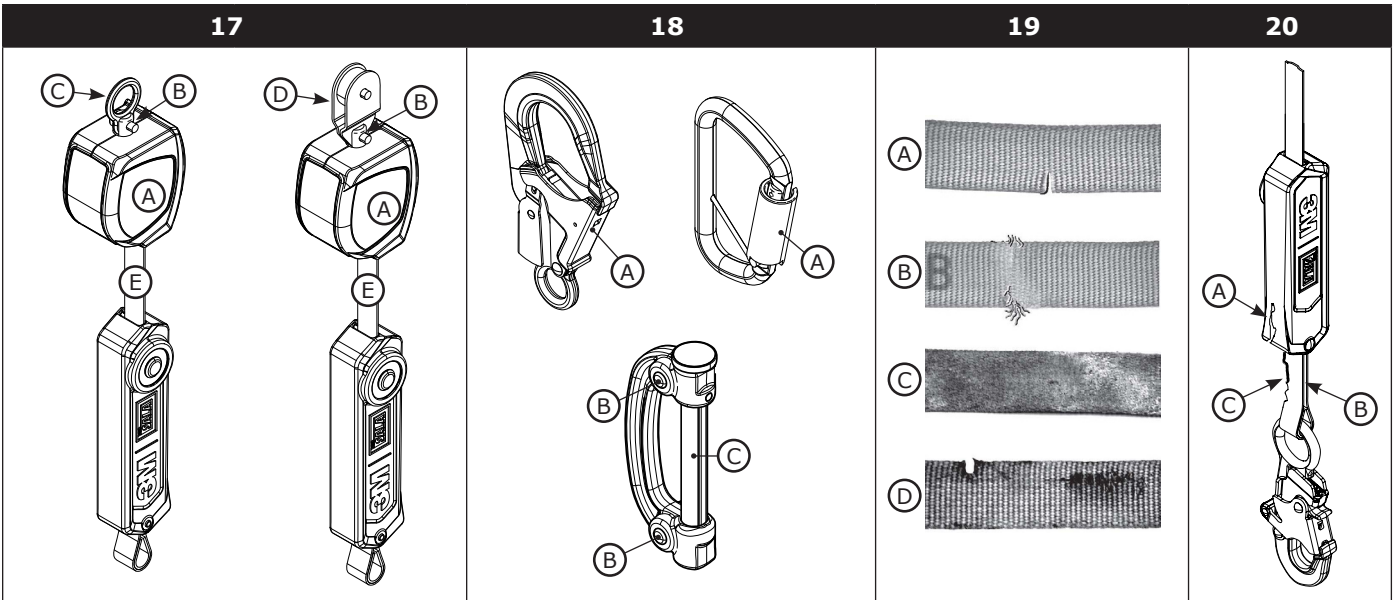

21

(A)

NANO-LOK™

ANSI Z359.14
CLASS A & B

(C)

INSPECTION LOG RELEVÉ D'INSPECTION			
DATE	INITIALS	DATE	INITIALS

Avg arresting force / Force d'arrêt moyenne: 900lbs (4kN)
Max arresting force / Force d'arrêt maximale: 1350lbs (6kN)

Lifeline material / Matériau de la corde d'assurance	Dyneema web / Sangle en dyneema	
0.781x0.052in (20x1.3mm)	130-310lbs (59-140kg)	310-420lbs (140-190kg)
User capacity / Capacité de l'utilisateur	3ft (0.91m)	2ft (0.61m)
Free fall limit / Limite de chute libre	24in (0.61m)	36" (0.91m)
Arrest distance / Distance d'arrêt	24in (0.61m)	30in (0.76m)

9514367 Rev. A

(A)

NANO-LOK™

(C)

INSPECTION LOG RELEVÉ D'INSPECTION			
DATE	INITIALS	DATE	INITIALS

Avg arresting force / Force d'arrêt moyenne: 900lbs (4kN)
Max arresting force / Force d'arrêt maximale: 1350lbs (6kN)

Lifeline material / Matériau de la corde d'assurance	Dyneema web / Sangle en dyneema	
0.781x0.052in (20x1.3mm)	130-310lbs (59-140kg)	310-420lbs (140-190kg)
User capacity / Capacité de l'utilisateur	3ft (0.91m)	2ft (0.61m)
Free fall limit / Limite de chute libre	24in (0.61m)	36" (0.91m)
Arrest distance / Distance d'arrêt	24in (0.61m)	42" (1.07m)

9514368 Rev. B

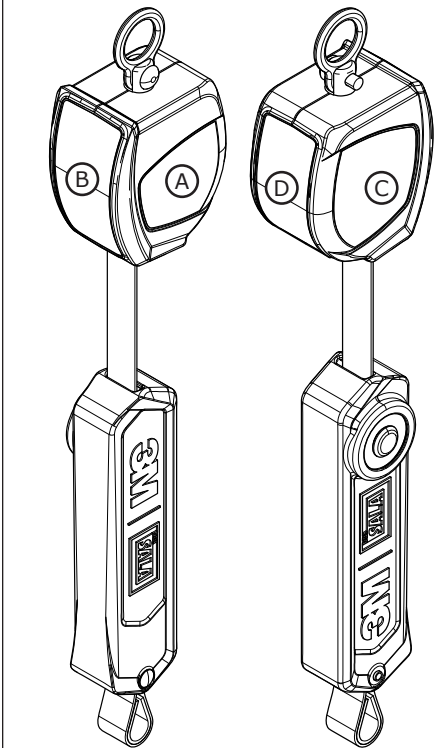

(B)

Model No:
N° De Modèle:

Lot #:

Mfr. (Yr, Mo):
Fabr. (An, Mo):

Length / Longueur (ft/m)

3M.com/FallProtection
Red Wing, MN 55066, USA

See RFID tag for Serial Number
Voir l'étiquette RFID pour le numéro de série

Patent Pending 9514365 Rev. A

(D)

Load Indicator / L'indicateur De Chute

Deployed or torn / frayed webbing
Sangle déployée ou déchirée / effilochée

Torn or broken cover
Déchiré ou cassé couvercle 9514367 Rev. A

Warning / Avertissement

Not for leading edge applications. Always refer to User Instructions for acceptable anchor locations. Suitable for use with approved Horizontal Lifelines. Test device for locking and retraction before use. Examine at least annually. For single user only. Avoid lanyard contact with sharp edges & abrasive surfaces. Follow all manufacturer's instructions included at time of shipping. This device shall be removed from service when the visual load indicator is deployed. / Ne convient pas en présence de bords tranchants. Consultez toujours le mode d'emploi pour connaître les emplacements d'ancrage acceptables. Inspecter au moins annuellement. Ne connecter qu'un seul utilisateur au dispositif. Éviter tout contact entre la sangle et les bords coupants ou les surfaces abrasives. Suivre toutes les instructions du fabricant fournies avec le dispositif lors de sa livraison. Ce dispositif doit être retiré du service lorsque l'indicateur de chute est active.

Please read, understand, and follow all safety information contained in these instructions prior to the use of this Self-Retracting Device (SRD). FAILURE TO DO SO COULD RESULT IN SERIOUS INJURY OR DEATH.

These instructions must be provided to the user of this equipment. Retain these instructions for future reference.

Intended Use:

This Self-Retracting Device is intended for use as part of a complete personal fall protection system.

Use in any other application including, but not limited to, material handling, recreational or sports related activities, or other activities not described in the User Instructions, is not approved by 3M and could result in serious injury or death.

This device is only to be used by trained users in workplace applications.

! WARNING

This Self-Retracting Device is part of a personal fall protection system. It is expected that all users be fully trained in the safe installation and operation of their personal fall protection system. **Misuse of this device could result in serious injury or death.** For proper selection, operation, installation, maintenance, and service, refer to these User Instructions including all manufacturer recommendations, see your supervisor, or contact 3M Technical Services.

- **To reduce the risks associated with working with an SRD which, if not avoided, could result in serious injury or death:**
 - Before each use, inspect the SRD and check for proper locking and retraction.
 - If inspection reveals an unsafe or defective condition, remove the device from service and repair or replace according to the User Instructions.
 - If the SRD has been subjected to fall arrest or impact force, immediately remove the SRD from service and label the device 'UNUSABLE'.
 - Ensure the lifeline is kept free from any and all obstructions including, but not limited to; entanglement with moving machinery or equipment (e.g., the top drive of oil rigs), other workers, yourself, surrounding objects, or impact from overhead objects that could fall onto the lifeline or the worker.
 - Never allow slack in the lifeline. Do not tie or knot the lifeline.
 - Attach the unused leg(s) of the Harness Mounted SRD to the parking attachment(s) of the harness if equipped.
 - Do not use in applications that have an obstructed fall path. Working on slowly shifting material, such as sand or grain, or within confined or cramped spaces, may not allow the worker to reach sufficient speed to cause the SRD to lock. A clear path is required to assure positive locking of the SRD.
 - Avoid sudden or quick movements during normal work operation. This may cause the device to lock up.
 - Ensure that fall protection systems/subsystems assembled from components made by different manufacturers are compatible and meet the requirements of applicable standards, including the ANSI Z359 or other applicable fall protection codes, standards, or requirements. Always consult a Competent and/or Qualified Person before using these systems.
 - (DEVICES WITH MAGNETS) Avoid close proximity to implanted medical devices.
- **To reduce the risks associated with working at height which, if not avoided, could result in serious injury or death:**
 - Ensure your health and physical condition allow you to safely withstand all of the forces associated with working at height. Consult with your doctor if you have any questions regarding your ability to use this equipment.
 - Never exceed allowable capacity of your fall protection equipment.
 - Never exceed maximum free fall distance of your fall protection equipment.
 - Do not use any fall protection equipment that fails pre-use or other scheduled inspections, or if you have concerns about the use or suitability of the equipment for your application. Contact 3M Technical Services with any questions.
 - Some subsystem and component combinations may interfere with the operation of this equipment. Only use compatible connections. Consult 3M prior to using this equipment in combination with components or subsystems other than those described in the User Instructions.
 - Use extra precautions when working around moving machinery (e.g. top drive of oil rigs) electrical hazards, extreme temperatures, chemical hazards, explosive or toxic gases, sharp edges, or below overhead materials that could fall onto you or your fall protection equipment.
 - Use Arc Flash or Hot Works devices when working in high heat environments.
 - Avoid surfaces and objects that can damage the user or equipment.
 - Ensure there is adequate fall clearance when working at height.
 - Never modify or alter your fall protection equipment. Only 3M or parties authorized in writing by 3M may make repairs to the equipment.
 - Prior to use of fall protection equipment, ensure a rescue plan is in place which allows for prompt rescue if a fall incident occurs.
 - If a fall incident occurs, immediately seek medical attention for the worker who has fallen.
 - Do not use a body belt for fall arrest applications. Use only a Full Body Harness.
 - Minimize swing falls by working as directly below the anchorage point as possible.
 - If training with this device, a secondary fall protection system must be utilized in a manner that does not expose the trainee to an unintended fall hazard.
 - Always wear appropriate personal protective equipment when installing, using, or inspecting the device/system.

Before using this equipment, record the product identification information from the ID label in the 'Inspection and Maintenance Log' at the back of this manual.

DESCRIPTION:

Figure 2 identifies key components of the 3M™ DBI-SALA® Nano-Lok Self-Retracting Devices (SRDs). Nano-Lok SRDs are drum wound Web Lifelines (A) with an in-line Energy Absorber (B) that retracts into a Nylon Housing (C). A Swivel Eye (D) on the top of the Housing allows attachment to a valid anchorage with a Carabiner (E) or Integral Captive-Eye Connector (F) and Snap Hook or Rebar Hook (G). One or two SRDs can mount on a Full Body Harness with a SRD Harness Interface (H). Figure 1 identifies available Nano-Lok models and their connector configurations. See Table 1 for Nano-Lok SRD and connector specifications.

Table 1 – Specifications

Component Specifications:

SRL Housings	Nylon
Drum	Nylon
Internal Components	Stainless Steel, Aluminum
Web Lifeline	Standard: Dynema Polyester
Energy Absorber	Cover: Rubber, Web: Polyester Vectran, Stitching: Polyester or Nylon Thread
Swivel	Zinc Plated Steel

Connector Specifications:

	Description	Material	Gate Opening	Gate Strength	Tensile Strength
①	Swivel Eye	Steel	0.88 in (22.35 mm) inside diameter		5,000 lbs (22.2 kN)
②	Carabiner	Aluminum	0.81 in (20 mm)	3,600 lbs (16 kN)	5,000 lbs (22.2 kN)
③	Carabiner	Steel	0.69 in (18 mm)	3,600 lbs (16 kN)	5,000 lbs (22.2 kN)
④	Fixed D-Ring SRD Harness Interface	Steel	3/4 in (19 mm)	3,600 lbs (16 kN)	5,000 lbs (22.2 kN)
⑤	Rebar Hook	Steel	2-1/2 in (63 mm)	3,600 lbs (16 kN)	5,000 lbs (22.2 kN)
⑥	Cab Mount	Stainless Steel	1-5/8 in (41 mm)		
⑦	SRD Harness Interface	Steel	2 in (51 mm)	3,600 lbs (16 kN)	5,000 lbs (22.2 kN)
⑧	Snap Hook	Steel	3/4 in (19 mm)	3,600 lbs (16 kN)	5,000 lbs (22.2 kN)
⑨	Carabiner	Aluminum	3/4 in (19 mm)	3,600 lbs (16 kN)	5,000 lbs (22.2 kN)
⑩	Carabiner	Steel	2.19 in (56 mm)		
⑪	Rebar Hook	Steel	2-1/2 in (63 mm)	3,600 lbs (16 kN)	5,000 lbs (22.2 kN)
⑫	Carabiner	Steel	0.69 in (18 mm)	3,600 lbs (16 kN)	5,000 lbs (22.2 kN)
⑬	Rebar Hook	Aluminum, Steel	2-1/2 in (63 mm)	3,600 lbs (16 kN)	5,000 lbs (22.2 kN)
⑭	Rebar Hook	Steel	2-1/4 in (57 mm)	3,600 lbs (16 kN)	5,000 lbs (22.2 kN)
⑮	Swivel Snap Hook	Steel	3/4 in (19 mm)	3,600 lbs (16 kN)	5,000 lbs (22.2 kN)
⑯	Snap Hook	Aluminum	1 in (25 mm)	3,600 lbs (16 kN)	5,000 lbs (22.2 kN)

Performance Specifications:

SRL Specifications (Z359.14 Class A/B)	ANSI/OSHA Models	OSHA Models
Capacity Range	130 lbs - 310 lbs (59 kg - 140 kg)	311 lbs - 420 lbs (141 kg - 190 kg)
Maximum Arresting Force	1,350 lbs (6 kN)	1,350 lbs (6 kN)
Average Arresting Force	900 lbs (4 kN)	900 lbs (4 kN)
Claimed Maximum Arresting Distance¹	24 in (0.61 m)	30 in (0.76 m)
Minimum Fall Clearance Required¹	4 ft (1.2 m)	4.5 ft (1.4 m)
Maximum Free Fall	3 ft (0.6 m)	2 ft (0.61 m)

SRL Specifications (Z359.14 Class B)	ANSI/OSHA Models	OSHA Models
Capacity Range	130 lbs - 310 lbs (59 kg - 140 kg)	311 lbs - 420 lbs (141 kg - 190 kg)
Maximum Arresting Force	1,350 lbs (6 kN)	1,350 lbs (6 kN)
Average Arresting Force	900 lbs (4 kN)	900 lbs (4 kN)
Claimed Maximum Arresting Distance¹	36 in (0.91 m)	42 in (1.07 m)
Minimum Fall Clearance Required¹	6 ft (1.8 m)	6.5 ft (2.0 m)
Maximum Free Fall	3 ft (0.91 m)	2 ft (0.61 m)

¹ - Assumes the SRL is mounted directly above (overhead) the end user.

1.0 APPLICATIONS

- 1.1 PURPOSE:** Self-Retracting Devices (SRDs) are designed to be a component in a personal fall arrest system (PFAS). Figure 1 illustrates SRDs covered by this instruction manual. They may be used in most situations where a combination of worker mobility and fall protection is required (i.e. inspection work, general construction, maintenance work, oil production, confined space work, etc.).
- 1.2 STANDARDS:** Your SRD conforms to the national or regional standard(s) identified on the front cover of these instructions. Refer to the local, state, and federal (OSHA) requirements governing occupational safety for additional information regarding Personal Fall Protection.
- 1.3 TRAINING:** This equipment is intended to be used by persons trained in its correct application and use. It is the responsibility of the user to assure they are familiar with these instructions and are trained in the correct care and use of this equipment. Users must also be aware of the operating characteristics, application limits, and the consequences of improper use.
- 1.4 LIMITATIONS:** Always consider the following limitations when installing or using this equipment:

- **Capacity:** SRDs are for use by one person with a combined weight (clothing, tools, etc.) meeting the *Capacity Range* specified in Table 1 for your standard(s). Make sure all of the components in your system are rated to a capacity appropriate to your application.
- **Anchorage:** Anchorages selected for fall arrest systems shall have a strength capable of sustaining static loads applied in the directions permitted by the system of at least:
 1. 5,000 lbs. (22.2 kN) for non-certified anchorages, or
 2. Two times the maximum arresting force for certified anchorages.

When more than one fall arrest system is attached to an anchorage, the strengths set forth in (1) and (2) above shall be multiplied by the number of systems attached to the anchorage.

From OSHA 1926.502 and 1910.140: Anchorages used for attachment of personal fall arrest systems shall be independent of any anchorage being used to support or suspend platforms, and capable of supporting at least 5,000 lbs. per user attached, or be designed, installed, and used as part of a complete personal fall arrest systems which maintains a safety factor of at least two, and is under the supervision of a qualified person.

- **Locking Speed:** Situations which do not allow for an unobstructed fall path should be avoided. Working in confined or cramped spaces may not allow the body to reach sufficient speed to cause the SRD to lock if a fall occurs. Working on slowly shifting material, such as sand or grain, may not allow enough speed buildup to cause the SRD to lock. A clear path is required to assure positive locking of the SRD.
- **Free Fall:** When used correctly with the SRD anchored directly overhead and no slack in the lifeline, SRDs will limit the free fall distance to 0 ft (0 cm)¹. To avoid increased fall distances, do not work above the anchorage level. **Do not lengthen SRDs by connecting a lanyard or similar component without consulting 3M.** Never clamp, knot, or prevent the lifeline from retracting or staying taut. Avoid slack line.
- **Swing Falls:** Swing Falls occur when the anchorage point is not directly above the point where a fall occurs. The force of striking an object in a swing fall may cause serious injury (see Figure 3A). Minimize swing falls by working as directly below the anchorage point as possible (Figure 3B).
- **Fall Clearance:** Figure 3B illustrates Fall Clearance Calculation. Fall Clearance (FC) is the sum of Free Fall (FF), Deceleration Distance (DD) and a Safety Factor (SF): $FC = FF + DD + SF$. D-Ring Slide and Harness Stretch are included in the Safety Factor. Fall Clearance values have been calculated and are charted in Figure 4. A Safety Factor of 1.5 ft (0.5 m) was used for all values in Figure 4.

For falls from a standing position where the SRD is anchored directly overhead (Figure 3B), SRD Fall Arrest Systems should have the minimum Fall Clearances specified in Table 1. Falls from a kneeling or crouching position will require an additional 3 ft (1 m) of Fall Clearance. In a swing fall situation (Figure 3C), the total vertical fall distance will be greater than if the user had fallen directly below the anchorage point and may require additional Fall Clearance. Figure 4 and the accompanying table define the Maximum Work Radius (C) for various SRD Anchorage Heights (A) and Fall Clearances (B). The Recommended Work Zone is limited to the area located within the Maximum Work Radius.

- **Hazards:** Use of this equipment in areas where surrounding hazards exist may require additional precautions to reduce the possibility of injury to the user or damage to the equipment. Hazards may include, but are not limited to: high heat, caustic chemicals, corrosive environments, high voltage power lines, explosive or toxic gases, moving machinery, or overhead materials that may fall and contact the user or fall arrest system. Avoid working where your lifeline may cross or tangle with that of another worker. Avoid working where an object may fall and strike the lifeline; resulting in loss of balance or damage to the lifeline. Do not allow the lifeline to pass under arms or between legs.
- **Sharp Edges:** Sharp edges the SRD lifeline can contact during a fall must have a minimum radius of 0.125 in (0.3 cm). Where contact with a sharp edge is unavoidable, cover the edge with a protective material.

¹ **Free Fall:** Correct application of the SRD, with the user working directly below the anchorage point and no lifeline slack, will eliminate Free Fall. Free Fall should be limited to 5 ft (1.5 m) for a 310 lb (141 kg) capacity where the user is not directly under the SRD or minimal slack exists in the lifeline. See Figure 4 for acceptable anchorage locations.

2.0 Use

- 2.1 FALL PROTECTION AND RESCUE PLAN:** The employer must have a Fall Protection and Rescue Plan in place that meets *ANSI Z359.2 Minimum Requirements for a Comprehensive Managed Fall Protection Program*. The plan should provide guidelines and requirements for an employer’s managed fall protection program, including policies, duties and training; fall protection procedures; eliminating and controlling fall hazards; rescue procedures; incident investigations; and evaluating program effectiveness.
- 2.2 INSPECTION FREQUENCY:** SRDs shall be inspected by the authorized person¹ or rescuer² before each use (See Table 3). Additionally, inspections shall be conducted by a competent person³ other than the user. Extreme working conditions (harsh environment, prolonged use, etc.) may necessitate more frequent competent person inspections. The competent person shall use the *Inspection Schedule (Table 2)* to determine appropriate inspection intervals. Inspection procedures are described in the *Inspection & Maintenance Log (Table 3)*. Results of the Competent Person inspection should be recorded in the *Inspection and Maintenance Log* or recorded with the Radio Frequency Identification (RFID) system (see *Section 5*).
- 2.3 NORMAL OPERATIONS:** Normal operation will allow the lifeline to extend and retract with no hesitation or slack as the worker moves at normal speeds. If a fall occurs, a speed sensing brake system will activate, stopping the fall and absorbing much of the energy created. Sudden or quick movements should be avoided during normal work operation, as this may cause the SRD to lock up. For falls which occur near the end of the lifeline travel, a reserve lifeline system or Energy Absorber has been incorporated to reduce the fall arrest forces.
- 2.4 BODY SUPPORT:** A Full Body Harness must be used with the Self-Retracting Device. The harness connection point must be above the user’s center of gravity. A body belt is not authorized for use with the Self-Retracting Device. If a fall occurs when using a body belt it may cause unintentional release or physical trauma from improper body support.
- 2.5 COMPATIBILITY OF COMPONENTS:** Unless otherwise noted, 3M equipment is designed for use with 3M approved components and subsystems only. Substitutions or replacements made with non approved components or subsystems may jeopardize compatibility of equipment and may affect safety and reliability of the complete system.
- 2.6 COMPATIBILITY OF CONNECTORS:** Connectors are considered to be compatible with connecting elements when they have been designed to work together in such a way that their sizes and shapes do not cause their gate mechanisms to inadvertently open regardless of how they become oriented. Contact 3M if you have any questions about compatibility. Connectors (hooks, carabiners, and D-rings) must be capable of supporting at least 5,000 lbs. (22.2 kN). Connectors must be compatible with the anchorage or other system components. Do not use equipment that is not compatible. Non-compatible connectors may unintentionally disengage (see Figure 5). Connectors must be compatible in size, shape, and strength. Self-locking snap hooks and carabiners are required. If the connecting element to which a snap hook or carabiner attaches is undersized or irregular in shape, a situation could occur where the connecting element applies a force to the gate of the snap hook or carabiner (A). This force may cause the gate to open (B), allowing the snap hook or carabiner to disengage from the connecting point (C).
- 2.7 MAKING CONNECTIONS:** Snap hooks and carabiners used with this equipment must be self-locking. Ensure all connections are compatible in size, shape and strength. Do not use equipment that is not compatible. Ensure all connectors are fully closed and locked. 3M connectors (snap hooks and carabiners) are designed to be used only as specified in each product’s user’s instructions. See Figure 6 for examples of inappropriate connections. Do not connect snap hooks and carabiners:
- To a D-ring to which another connector is attached.
 - In a manner that would result in a load on the gate. Large throat snap hooks should not be connected to standard size D-rings or similar objects which will result in a load on the gate if the hook or D-ring twists or rotates, unless the snap hook is equipped with a 3,600 lb (16 kN) gate.
 - In a false engagement, where size or shape of the mating connectors are not compatible and, without visual confirmation, the connectors seem fully engaged.
 - To each other.
 - Directly to webbing or rope lanyard or tie-back (unless the manufacturer’s instructions for both the lanyard and connector specifically allows such a connection).
 - To any object which is shaped or dimensioned such that the snap hook or carabiner will not close and lock, or that roll-out could occur.
 - In a manner that does not allow the connector to align properly while under load.

Table 2 – Inspection Schedule

Type of Use	Application Examples	Conditions of Use	Inspection Frequency
			Competent Person
Infrequent to Light	Rescue and Confined Space, Factory Maintenance	Good Storage Conditions, Indoor or Infrequent Outdoor Use, Room Temperature, Clean Environments	Annually
Moderate to Heavy	Transportation, Residential Construction, Utilities, Warehouse	Fair Storage Conditions, Indoor and Extended Outdoor Use, All Temperatures, Clean or Dusty Environments	Semi-Annually to Annually
Sever to Continuous	Commercial Construction, Oil and Gas, Mining	Harsh Storage Conditions, Prolonged or Continuous Outdoor Use, All Temperatures, Dirty Environment	Quarterly to Semi-Annually

1 Authorized Person: A person assigned by the employer to perform duties at a location where the person will be exposed to a fall hazard.

2 Rescuer: Person or persons other than the rescue subject acting to perform an assisted rescue by operation of a rescue system.

3 Competent Person: An individual designated by the employer to be responsible for the immediate supervision, implementation, and monitoring of the employer’s managed fall protection program who, through training and knowledge, is capable of identifying, evaluating, and addressing existing and potential fall hazards, and who has the employer’s authority to take prompt corrective action with regard to such hazards.

3.0 Installation

- 3.1 PLANNING:** Plan your fall protection system before starting your work. Account for all factors that may affect your safety before, during, and after a fall. Consider all requirements and limitations defined in Section 2.

In most applications, the Nano-Lok SRD can be connected to the anchorage or the harness Dorsal location. Either orientation is allowed; except as noted in Section Section 4

- 3.2 ANCHORAGE:** Figure 7 illustrates typical SRD anchorage connections. Select an anchorage location with minimal free fall and swing fall hazards (see Section 1). Select a rigid anchorage point capable of sustaining the static loads defined in Section 1. Where anchoring overhead is not feasible, Nano-Lok SRDs may be secured to an anchorage point below the level of the user's Dorsal D-Ring. For users up to 310 lbs (140 kg), the anchorage point must not be more than 3 ft (0.9 m) below the Dorsal D-Ring.

- 3.3 HARNESS MOUNTING:** Some SRD models include a Single SRD or Twin SRD Harness Interface for mounting the SRD(s) on a Full Body Harness just below the Dorsal D-Ring:

Some Full Body Harnesses are equipped with a Personal SRD Link (PSRL Link) that integrates the Dorsal D-Ring with attachment elements for Harness Mounted Self-Retracting Devices (Figure 8). It is also acceptable to connect the SRD to the Harness Dorsal D-Ring with a Carabiner or Snaphook.

- **Single SRD Harness Mounting:** Where worker mobility is critical, an SRD Harness Interface can be used to mount the SRD on the back of a Full Body Harness just below the Dorsal D-Ring (see Figure 9). The worker can then connect to varied anchorage points located throughout the site with the Lanyard End of the SRD without repeatedly reinstalling the SRD. To mount the SRD on a Full Body Harness with the SRD Harness Interface:

1. **Loosen the Harness Webbing:** Pull out on the Web Straps (A) where they pass through the bottom of the Dorsal D-Ring (B) until there is sufficient space to slide the SRD Harness Interface between the Web Straps and D-Ring Pad.
2. **Open the Harness Interface:** Push down on the Locking Buttons (C) simultaneously and slide the Locking Pin (D) out.
3. **Position the SRD on the Harness Interface:** Insert the open gate on the Harness Interface through the Swivel Eye on the SRD (E). Thread the Interface through the Swivel Eyes so the SRD hangs from the backbone of the Harness Interface (F).
4. **Position the Harness Interface around the Web Straps:** Position the open gate of the Harness Interface around the loose Web Straps (A).
5. **Close the Harness Interface:** Push the Harness Interface Locking Pin (D) through the loose Web Straps (A) until it locks in place in the opposite end of the Harness Interface. Pull the Web Straps back through the Dorsal D-Ring and Back Pad to secure the Harness Interface.

The Red Band on the knob end of the Harness Interface Locking Pin will be exposed if the Harness Interface is unlocked. To avoid accidental release of the connection, always make sure the Harness Interface is locked before using the Harness and attached SRD. Failure to do so could result in injury or death.

- **Twin SRD Harness Mounting:** In climbing applications where 100% tie-off is required, the SRD Harness Interface can be used to mount two SRDs side-by-side on the back of a Full Body Harness just below the Dorsal D-Ring (see Figure 9) To mount two SRDs on a Full Body Harness with the SRD Harness Interface:

1. **Loosen the Harness Webbing:** Pull out on the Web Straps (A) where they pass through the bottom of the Dorsal D-Ring (B) until there is sufficient space to slide the SRD Harness Interface between the Web Straps and D-Ring Pad.
2. **Open the Harness Interface:** Push down on the Locking Buttons (C) simultaneously and slide the Locking Pin (D) out.
3. **Position the SRDs on the Harness Interface:** Insert the open gate on the Harness Interface through the Swivel Eye on each SRD (E). Thread the Interface through the Swivel Eyes so the SRDs hang from the backbone of the Harness Interface (F).
4. **Position the Harness Interface around the Web Straps:** Position the open gate of the Harness Interface around the loose Web Straps (A).
5. **Close the Harness Interface:** Push the Harness Interface Locking Pin (D) through the loose Web Straps (A) until it locks in place in the opposite end of the Harness Interface. Pull the Web Straps back through the Dorsal D-Ring and Back Pad to secure the Harness Interface.

The Red Band on the knob end of the Harness Interface Locking Pin will be exposed if the Harness Interface is unlocked. To avoid accidental release of the connection, always make sure the Harness Interface is locked before using the Harness and attached SRD. Failure to do so could result in injury or death.

- **Twin SRD Fixed D-Ring Harness Mounting:** Older ExoFit Full Body Harnesses with a Fixed D-Ring require a special SRD Harness Interface to mount two SRDs on the back of the harness just below the Dorsal D-Ring. See Figure 10:
 1. **Loosen the Harness Webbing:** Pull out on the Web Straps (A) where they pass through the bottom of the Dorsal D-Ring (B) until there is sufficient space to insert the SRD Harness Interface between the Web Straps and Back Pad.
 2. **Open the Harness Interface:** With the SRD Harness Interface orientated as illustrated, push the Locking Sleeve (C) to the right and then turn clockwise to unlock the Gate (D). Swing the Gate (D) down to open.
 3. **Thread the first SRD onto the Harness Interface:** Insert the Nose of the Connector (E) through the Swivel Eye (F) on the SRD and then rotate the SRD around to the Gate End of the Connector (G). The Gate can be closed to allow clearance for the Swivel Eye between the Gate and Spine of the Connector.
 4. **Position the Harness Interface around the Web Straps:** Insert the Nose of the Connector (E) behind the Web Straps (A). Rotate the Connector behind the Web Straps until the Connector surrounds the Web Straps.
 5. **Add the second SRD on the Harness Interface:** Slide the SRD Swivel Eye (F) over the Nose of the Connector (E) and position the SRD Swivel Eye in the Nose End of the Connector.
 6. **Close the Harness Interface:** Allow the Gate (D) to swing closed and the Locking Sleeve (C) to rotate back to locked position. Once the Harness Interface is closed, pull the Web Straps (A) back through the Dorsal D-Ring to eliminate slack in the webbing and secure the Harness Interface between the Web Straps and Back Pad.
- **3M® DBI-SALA® Twin Pin Carabiner:** This harness attachment can be used to mount one Nano-Lok SRL, or two Nano-Lok SRLs in climbing applications where 100% tie-off is required. See Figure 11:
 1. **Loosen the Harness Webbing:** Pull out on the Web Straps (A) where they pass through the bottom of the Dorsal D-Ring (B) until there is sufficient space to slide the Twin Leg Interface between the Web Straps and D-Ring Pad.
 2. **For single configuration:** Place the swivel eye of a single SRL in the center open space.
 3. **For twin configuration:** place the swivel eye of one SRL in the open space closest to the pin and one SRL in the open space farthest from the pin.
 4. Slide the pin back in place until you hear a click. The pin should be firmly locked in place.
 5. Simultaneously depress the two buttons on the harness side of the connector while sliding the pin out. Sliding this pin out creates an open space.
 6. Pull up a small amount of slack in the webbing directly beneath the dorsal D-Ring on your harness. Place the harness side of the connector beneath the D-Ring.
 7. Slide the pin back in place ensuring that the pin remains beneath both layers of harness webbing until you hear a click. The pin should be firmly locked in place.
- **3M® DBI-SALA® Twin Carabiner:** The 3M® DBI-SALA® Twin Carabiner is designed to mount two Nano-Lok SRDs side-by-side on the back of a Full Body Harness just below the Dorsal D-Ring. See Figure 12:
 1. **Loosen the Harness Webbing:** Pull out on the Web Straps (A) where they pass through the bottom of the Dorsal D-Ring (B) until there is sufficient space to slide the Twin Leg Interface between the Web Straps and D-Ring Pad.
 2. **Open the Twin Carabiner:** Push up on the Connector Insert (C) to unsnap the Clamps (D) from the Connector and then swing the Connector Insert up to unlock the Gate. Push the Gate (E) inward to open the Connector.
 3. **Thread the first Nano-Lok SRD onto the Twin Carabiner:** Insert the nose of the Connector (F) through the Swivel Eye (G) on the SRL and then rotate the SRL around to the Gate End of the Connector (H). The Gate can be rotated toward the nose to allow clearance for the Swivel Eye between the Gate and Spine of the Connector.
 4. **Position the Twin Carabiner around the Web Straps:** With the Gate facing up, insert the nose of the Connector (F) behind the Web Straps (A). Rotate the Connector behind the Web Straps until the Connector surrounds the the Web Straps.
 5. **Add the second Nano-Lok SRD on the Twin Carabiner:** Slide the SRL Swivel Eye (G) over the nose of the Connector (F) and position the SRL Swivel Eye in the nose end of the Connector (F). Swing the Gate (E) closed.
 6. **Close the Twin Carabiner:** Rotate the Connector Insert (C) forward so the Clamps (D) secure on the Connector. When properly closed, the Web Straps should pass through the Webbing Slot (J) at the top of the Connector Insert and the SRL Swivel Eyes should be secured in the Recesses (K) on either side of the Connector Insert. Once the Harness Interface is closed, pull the Web Straps (A) back through the Dorsal D-Ring and D-Ring Pad to eliminate slack in the webbing and secure the Connector between the Web Straps and D-Ring Pad.

4.0 OPERATION

First time or infrequent users of Self-Retracting Devices (SRDs) should review the "Safety Information" at the beginning of this manual prior to use of the SRD.

- 4.1 **BEFORE EACH USE:** Before each use of this fall protection equipment carefully inspect it to assure it is in good working condition. Check for worn or damaged parts. Ensure all bolts are present and secure. Check that the lifeline is retracting properly by pulling out the line and allowing it to slowly retract. If there is any hesitation in retraction the unit should be removed from service and destroyed. Inspect the lifeline for cuts, frays, burns, crushing and corrosion. Check locking action by pulling sharply on the line. See the Inspection and Maintenance Log (Table 3) for inspection details. Do not use if inspection reveals an unsafe condition.
- 4.2 **AFTER A FALL:** Any equipment which has been subjected to the forces of arresting a fall or exhibits damage consistent with the effect of fall arrest forces as described in Table 3, must be removed from service immediately and destroyed.
- 4.3 **BODY SUPPORT:** A full body harness must be worn when using SRDs. For general fall protection use, connect to the

back (dorsal) D-ring.

- 4.4 MAKING CONNECTIONS:** Figure 12 illustrates harness and anchorage connections for SRD Fall Arrest Systems. When using a hook to make a connection, ensure roll-out cannot occur (see Figure 5). Do not use hooks or connectors that will not completely close over the attachment object. Do not use non-locking snap hooks. The anchorage must meet the anchorage strength requirements stated in Table 2. Follow the manufacturer instructions supplied with each system component.
- 4.5 OPERATION:** Prior to use, inspect the SRD as described in Table 3. Figure 11 shows system connections for typical SRD applications. Connect the SRD to a suitable anchorage or mount the SRD on the back of a Full Body Harness per the instructions in Section 3. On anchorage connected SRDs, connect the Hook (D) or Carabiner on the Load Indicator to the Dorsal D-Ring (A) on the Full Body Harness. On harness mounted SRDs, connect the Hook (D) or Carabiner to a suitable anchorage. Ensure connections are compatible in size, shape, and strength. Ensure hooks are fully closed and locked. Once attached, the worker is free to move about within the recommended working area at normal speeds. If a fall occurs the SRD will lock and arrest the fall. Upon rescue, remove the SRD from use. When working with an SRD, always allow the lifeline to recoil back into the device under control.
- 4.6 TWIN SRD INTERFACE 100% TIE-OFF:** When two SRDs are mounted side-by-side on the back of a Full Body Harness, the SRD Fall Arrest System can be used for continuous fall protection (100 % tie-off) while ascending, descending, or moving laterally (see Figure 12). With the Lanyard Leg of one SRD attached to an anchorage point, the worker can move to a new location, attach the unused Lanyard Leg of the other SRD to another anchorage point, and then disconnect from the original anchorage point. The sequence is repeated until the worker reaches the desired location. Considerations for Twin SRD 100% tie-off applications include the following:
- Never connect both SRD Lanyards to the same anchorage point (see Figure 13A).
 - Connecting more than one connector into a single anchorage (ring or eye) can jeopardize compatibility of the connection due to interaction between connectors and is not recommended.
 - Connection of each SRD Lanyard to a separate anchorage point is acceptable (Figure 13B).
 - Each connection location must independently support 2,248 lbs (10 kN) or be an engineered system, as with a Horizontal Lifeline.
 - Never connect more than one person at a time to the Twin SRD system (Figure 13C).
 - Do not allow the Lanyards to become tangled or twisted together as this may prevent them from retracting.
 - Do not allow any lanyard to pass under arms or between legs during use.
- 4.7 Aerial Work Platforms:** Use of the SRD on aerial work platforms is permissible, provided the following criteria are met:
1. SRDs generally will not restrain workers from falling out of aerial work platforms or elevated working surfaces. To restrain users from falling out of aerial work platforms, Positioning Lanyards of sufficiently short lengths should be used.
 2. Aerial work platforms must have guardrails or gates at all accessible edges along their perimeter unless anchorages for the SRDs are located overhead. The edges on the top rails of all guardrails and gates over which the user might fall must have a minimum radius of 1/8 in (0.3 cm).
 3. Anchorages of appropriate strength and compatibility must always be used for securing SRDs (see Section 2).
 4. Swing fall hazards may exist, especially when working near corners or out away from anchorage points. Added fall clearance is needed where the potential for swing fall exists (see Figure 3).
 5. All sharp edges which the SRD's lifeline may contact during a fall must be eliminated or covered over. All edges the SRD lifeline may contact in a fall must be smooth with an edge radius of 1/8 in (0.3 cm) or greater. Potential pinch points between adjacent surfaces where the lifeline may catch during a fall must be eliminated.
- 4.8 HORIZONTAL SYSTEMS:** In applications where the SRD is used in conjunction with a horizontal system (i.e. Horizontal Lifeline, Horizontal I-Beams Trolley), the SRD and horizontal system components must be compatible. Horizontal systems must be designed and installed under the supervision of a qualified engineer. Consult the horizontal system equipment manufacturer's instructions for details.

Fall Clearance values in Figure 4 are based on anchoring to a rigid, stationary anchor point and do not apply to anchoring to a Horizontal Lifeline (HLL) system. Consult the HLL Instruction Manual and HLL Installer to determine required Fall Clearances.

5.0 Inspection

- 5.1 RFID TAG:** The Self-Retracting Device includes a Radio Frequency Identification (RFID) tag (see Figure 13). The RFID tag can be used with the handheld reading device and web based portal to simplify inspection and inventory control and provide records for your fall protection equipment. For details, contact a 3M Customer Service representative (see back cover). Follow the instructions provided with your handheld reader, or on the web portal, to transfer your data to your web log.
- 5.2 INSPECTION FREQUENCY:** The Self-Retracting Device must be inspected at the intervals defined in Section 2. Inspection procedures are described in the "Inspection & Maintenance Log" (Table 3).

Extreme working conditions (harsh environments, prolonged use, etc.) may require increasing the frequency of inspections (see Table 2).

5.2 UNSAFE OR DEFECTIVE CONDITIONS: If inspection reveals an unsafe or defective condition, remove the SRD from service immediately and discard (see Section 6).

Only 3M or parties authorized in writing may make repairs to this equipment.

5.3 PRODUCT LIFE: The functional life of 3M Self-Retracting Devices is determined by work conditions and maintenance. As long as the product passes inspection criteria, it may remain in service.

6.0 MAINTENANCE, SERVICE, and STORAGE

6.1 CLEANING: Cleaning procedures for the SRD are as follows:

- Periodically clean the exterior of the SRD using water and a mild soap solution. Position the SRD so excess water can drain out. Clean labels as required.
- Clean the Web Lifeline with water and mild soap solution. Rinse and thoroughly air dry. Do not force dry with heat. The lifeline should be dry before allowing it to retract into the housing. An excessive buildup of dirt, paint, etc. may prevent the lifeline from fully retracting back into the housing causing a potential free fall hazard.

6.2 SERVICE: SRDs are not repairable. If the SRD has been subjected to fall force or inspection reveals an unsafe or defective condition, remove the SRD from service and discard (see "Disposal").

6.3 STORAGE/TRANSPORT: Store and transport SRDs in a cool, dry, clean environment out of direct sunlight. Avoid areas where chemical vapors may exist. Thoroughly inspect the SRD after any period of extended storage.

6.4 DISPOSAL: Dispose of the SRD if it has been subjected to fall arrest forces or inspection reveals an unsafe or defective condition. Before disposing of the SRD, cut the lifeline in half or otherwise disable the SRD to eliminate the possibility of inadvertent reuse.

7.0 Labels

Figure 21 illustrates labels on the the Self-Retracting Devices and their locations. All labels must be present on the SRD. Labels must be replaced if they are not fully legible.

U.S. PRODUCT WARRANTY, LIMITED REMEDY AND LIMITATION OF LIABILITY

WARRANTY: THE FOLLOWING IS MADE IN LIEU OF ALL WARRANTIES OR CONDITIONS, EXPRESS OR IMPLIED, INCLUDING THE IMPLIED WARRANTIES OR CONDITIONS OF MERCHANTABILITY OR FITNESS FOR A PARTICULAR PURPOSE.

Unless otherwise provided by applicable law, 3M fall protection products are warranted against factory defects in workmanship and materials for a period of one year from the date of installation or first use by the original owner.

LIMITED REMEDY: Upon written notice to 3M, 3M will repair or replace any product determined by 3M to have a factory defect in workmanship or materials. 3M reserves the right to require product be returned to its facility for evaluation of warranty claims. This warranty does not cover product damage due to wear, abuse, misuse, damage in transit, failure to maintain the product or other damage beyond 3M's control. 3M will be the sole judge of product condition and warranty options.

This warranty applies only to the original purchaser and is the only warranty applicable to 3M's fall protection products. Please contact 3M's customer service department at 800-328-6146 or via email at 3MFallProtection@mmm.com for assistance.

LIMITATION OF LIABILITY: TO THE EXTENT PERMITTED BY APPLICABLE LAW, 3M IS NOT LIABLE FOR ANY INDIRECT, INCIDENTAL, SPECIAL OR CONSEQUENTIAL DAMAGES INCLUDING, BUT NOT LIMITED TO LOSS OF PROFITS, IN ANY WAY RELATED TO THE PRODUCTS REGARDLESS OF THE LEGAL THEORY ASSERTED.



Fall Protection

USA

3833 SALA Way
Red Wing, MN 55066-5005
Toll Free: 800.328.6146
Phone: 651.388.8282
Fax: 651.388.5065
3Mfallprotection@mmm.com

Brazil

Rua Anne Frank, 2621
Boqueirão Curitiba PR
81650-020
Brazil
Phone: 0800-942-2300
falecoma3m@mmm.com

Mexico

Calle Norte 35, 895-E
Col. Industrial Vallejo
C.P. 02300 Azcapotzalco
Mexico D.F.
Phone: (55) 57194820
3msaludocupacional@mmm.com

Colombia

Compañía Latinoamericana de Seguridad S.A.S.
Carrera 106 #15-25 Interior 105 Manzana 15
Zona Franca - Bogotá, Colombia
Phone: 57 1 6014777
fallprotection-co@mmm.com

Canada

260 Export Boulevard
Mississauga, ON L5S 1Y9
Phone: 905.795.9333
Toll-Free: 800.387.7484
Fax: 888.387.7484
3Mfallprotection-ca@mmm.com

EMEA (Europe, Middle East, Africa)

EMEA Headquarters:
Le Broc Center
Z.I. 1re Avenue - BP15
06511 Carros Le Broc Cedex
France
Phone: + 33 04 97 10 00 10
Fax: + 33 04 93 08 79 70
informationfallprotection@mmm.com

Australia & New Zealand

95 Derby Street
Silverwater
Sydney NSW 2128
Australia
Phone: +(61) 2 8753 7600
Toll-Free : 1800 245 002 (AUS)
Toll-Free : 0800 212 505 (NZ)
Fax: +(61) 2 8753 7603
anzfallprotectionsales@mmm.com

Asia

Singapore:
1 Yishun Avenue 7
Singapore 768923
Phone: +65-6450 8888
Fax: +65-6552 2113
TotalFallProtection@mmm.com

Shanghai:

19/F, L'Avenue, No.99 Xian Xia Rd
Shanghai 200051, P R China
Phone: +86 21 62539050
Fax: +86 21 62539060
3MFallProtection-CN@mmm.com

Korea:

3M Korea Ltd
20F, 82, Uisadang-daero,
Yeongdeungpo-gu, Seoul
Phone: +82-80-033-4114
Fax: +82-2-3771-4271
TotalFallProtection@mmm.com

Japan:

3M Japan Ltd
6-7-29, Kitashinagawa, Shinagawa-ku, Tokyo
Phone: +81-570-011-321
Fax: +81-3-6409-5818
psd.jp@mmm.com

WEBSITE:
3M.com/FallProtection



EU DECLARATION OF CONFORMITY:
3M.com/FallProtection/DOC