



The Ultimate in Fall Protection

SecuraSpan™
Horizontal Lifeline System
I-Beam Stanchion
 Model Numbers: (See inside back cover.)

USER INSTRUCTION MANUAL HORIZONTAL LIFELINE SYSTEM

This manual is intended to meet the Manufacturer's Instructions requirement of applicable standards defined in Section 1.2 and should be used as part of an employee training program as required by the identified agencies.

WARNING: This product is part of a fall protection system. Users must read and follow the manufacturer's instructions for each component or part of the complete system. These instructions must be provided to the user of this equipment. The user must read and understand these instructions or have them explained to them before using this equipment. Manufacturer's instructions must be followed for proper use and maintenance of this product. Alterations or misuse of this product or failure to follow instructions may result in serious injury or death.

IMPORTANT: If you have questions on the use, care, or suitability of this equipment for your application, contact Capital Safety.

IMPORTANT: Record the product identification information from the ID label in the Inspection and Maintenance Log in Section 9 of this manual.

DESCRIPTION:

The SecuraSpan I-Beam Stanchion is used as the end and intermediate Stanchions for Horizontal Lifeline (HLLs) mounted on steel I-beams. SecuraSpan HLL systems can be comprised of a single Lifeline span or multiple Lifeline spans. Figure 1 illustrates typical SecuraSpan Steel Beam HLL systems and key components.

Figure 1 - SecuraSpan® I-Beam Horizontal Lifeline Systems

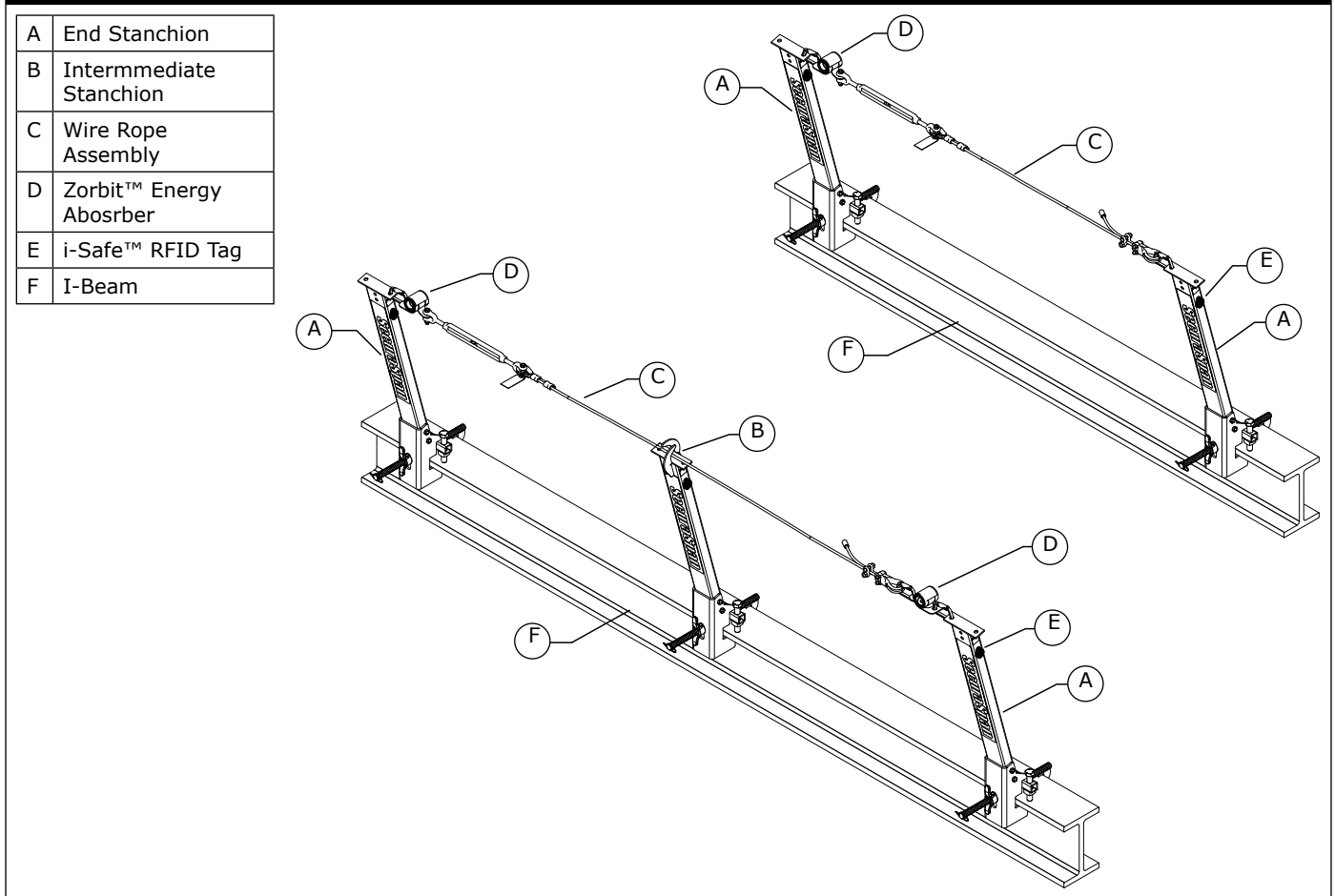

1.0 APPLICATION

1.1 PURPOSE: SecuraSpan® Horizontal Lifeline (HLL) systems are designed to be used as an anchoring means for up to six personal fall arrest systems (PFAS). The SecuraSpan system may be used in situations where a combination of horizontal mobility and fall protection is needed. The SecuraSpan HLL system can consist of a single Lifeline span or multiple Lifeline spans. Figure 1 illustrates single span and multiple span SecuraSpan HLL configurations.

IMPORTANT: OSHA regulations state that horizontal lifelines shall be installed and used under the supervision of a qualified person¹ as part of a complete personal fall arrest system that maintains a safety factor of at least two.

1.2 STANDARDS: Refer to local, state, and federal (OSHA) requirements governing occupational safety for additional information regarding Personal Fall Arrest Systems. Refer to the following national standards on fall protection:

ANSI	Z359-0	Definitions and Nomenclature Used for Fall Protection and Fall Arrest
ANSI	Z359-1	Safety Requirements for Personal Fall Arrest Systems, Subsystems, and Components
ANSI	Z359-2	Minimum Requirements for a Comprehensive Managed Fall Protection Program
ANSI	A10-14	Safety Requirements for Safety Belts, Harnesses, Lanyards, and Lifelines for Construction and Demolition Use
OSHA	1910.66	Personal Fall Arrest System
OSHA	1926.502	Fall Protection Systems Criteria and Practices

1.3 TRAINING: This equipment is intended to be used by persons trained in its correct application and use. It is the responsibility of the user to assure they are familiar with these instructions and are trained in the correct care and use of this equipment. Users must also be aware of the operating characteristics, application limits, and the consequences of improper use.

2.0 SYSTEM LIMITATIONS & REQUIREMENTS

Consider the following limitations/requirements prior to installing or using this equipment:

2.1 HORIZONTAL LIFELINE SPAN: The maximum horizontal lifeline span length is 60 ft. (18.3 m). The system length can be extended by using Intermediate Stanchions to create multiple spans (see Figure 1). The span length must be reduced when clearance is limited (see Figure 5 and Figure 6).

2.2 ANCHORAGES: SecuraSpan HLL systems must only be installed on anchorages meeting the following requirements:

- **Beam Size Requirements** - The SecuraSpan HLL Stanchions may be installed onto beam flanges with the dimensions identified in Figure 2. The standard Stanchion (7400047) is equipped with a Beam Clamp Assembly that accommodates flange widths (X) from 6 in. - 12 in. (15 cm - 30 cm). Optional Base Clamp Assemblies (2A) are available for the flange width ranges identified in Figure 2.

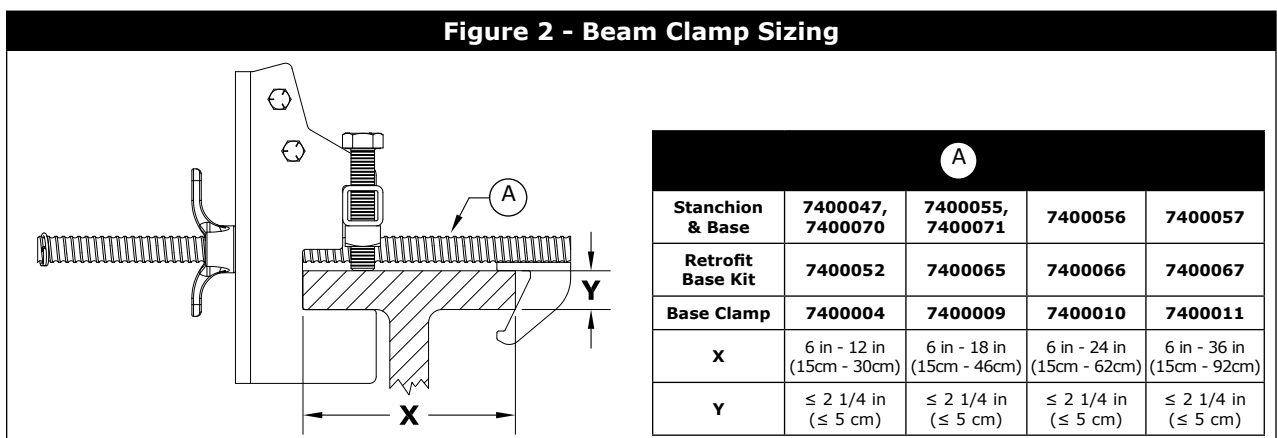

- **Beam Load Requirements** - Beams on which the SecuraSpan HLL system is installed must support the loads applied by the system during a fall arrest. Stanchion attachment points may be subjected to horizontal and vertical forces, and torsional loads. The beam on which the horizontal lifeline stanchions are installed must be sufficiently secured to support the Applied Load (AL) and Applied Moment (AM) capacities specified in Figure 3. Cumulative loading must be evaluated when more than one system is installed on a beam.

¹ **Qualified Person:** An individual with a recognized degree or professional certificate, and extensive knowledge and experience in the subject field, who is capable of design, analysis, evaluation, and specification in the subject work, project, or product. Refer to OSHA 1910.66, 1926.32, and 1926.502.

Figure 3 - Beam Load Requirements

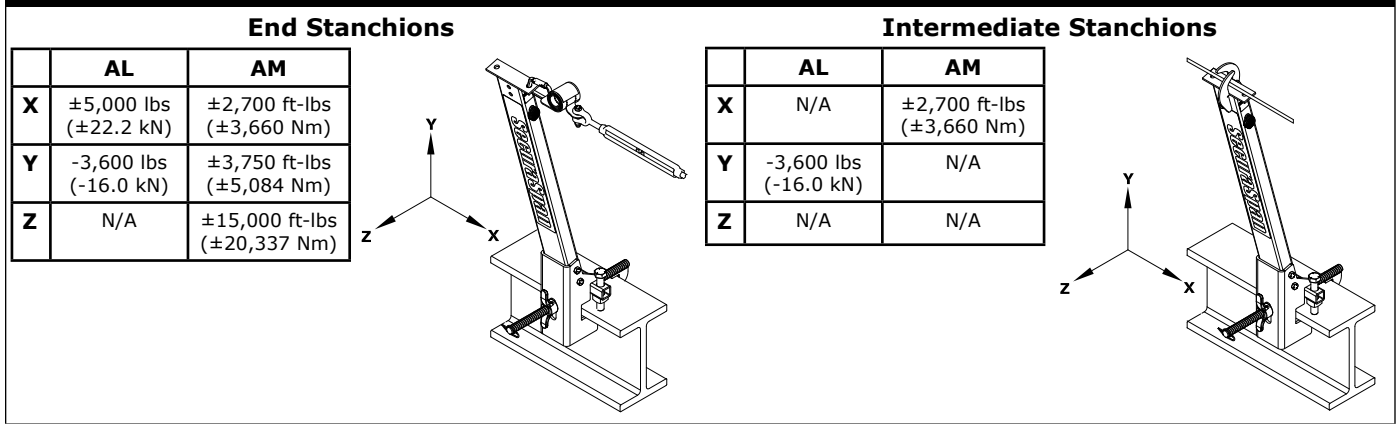

NOTE: The values in Figure 3 include a safety factor of two times the actual allowable applied loads.

- 2.3 SYSTEM CAPACITY:** The capacity of single span systems is two persons. The capacity of multiple span systems is two persons secured on each span with a maximum of six people installed on the system. The maximum weight of each person, including tools and clothing, is 310 lbs (141 kg).
- 2.4 FREE FALL:** Rig and use the personal fall arrest system such that the maximum potential free fall does not exceed government regulatory and subsystem manufacturer’s requirements. Personal Fall Arrest subsystems used with the SecuraSpan Horizontal Lifeline System must limit free fall to 6 feet (1.8 m) when using an Energy Absorbing Lanyard.
- 2.5 SWING FALLS:** Figure 4 illustrates a Swing Fall hazard. Swing falls occur when the Anchorage Point (A) is not in line vertically with the worker. The force of striking an object in a swing fall may cause serious injury or death. Minimize swing falls by working as directly in line with the anchorage point as possible. Do not permit a swing fall if injury could occur. Swing falls will significantly increase the clearance required when a self retracting lifeline or other variable length connecting subsystem (B) is used. If a swing fall situation exists in your application, contact Capital Safety before proceeding.

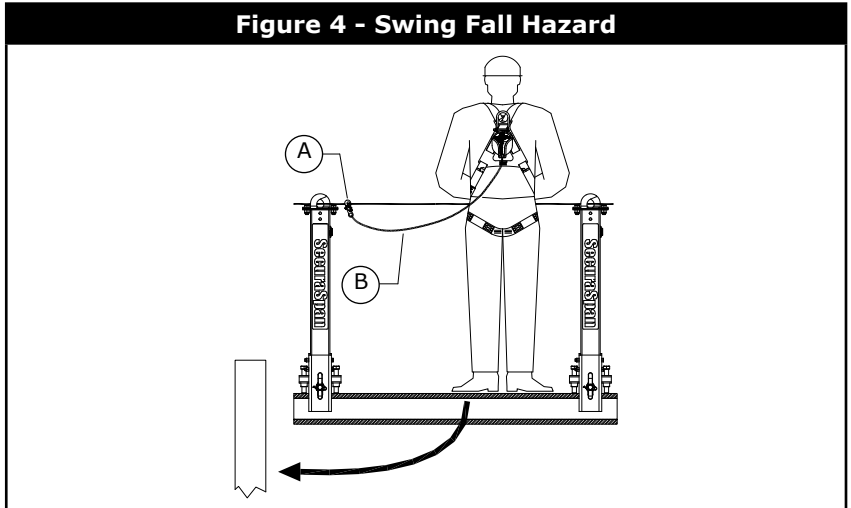

- 2.6 FALL CLEARANCE:** Ensure that adequate clearance exists in the fall path to prevent striking an object during a fall. The clearance required is dependent on the type and length of connecting subsystem (rope grab, lanyard), the anchorage location and the HLL Span Length. Figure 5 and Figure 6 identify span and clearance approximations for HLL systems utilizing Energy Absorbing Lanyard or Self Retracting Lifeline subsystems.
- 2.7 PHYSICAL AND ENVIRONMENTAL HAZARDS:** Use of this equipment in areas where physical or environmental hazards exist may require additional precautions to reduce the possibility of injury to the user or damage to the equipment. Hazards may include, but are not limited to: high heat, caustic chemicals, corrosive environments, high voltage power lines, explosive or toxic gases, moving machinery, or sharp edges. Contact Capital Safety if you have question regarding use of this equipment where physical or environmental hazards exist.
- 2.8 BODY SUPPORT:** A Full Body Harness must be used with the SecuraSpan Horizontal Lifeline System. The harness connection point must be above the user’s center of gravity. A body belt is not authorized for use with the HLL system. If a fall occurs when using a body belt it may cause unintentional release and possible suffocation because of improper body support. Substitutions of equipment or system components must not be made without the written consent of Capital Safety.
- 2.9 COMPATIBILITY OF COMPONENTS:** Unless otherwise noted, DBI-SALA equipment is designed for use with Capital Safety approved components and subsystems only. Substitutions or replacements made with non-approved components or subsystems may jeopardize compatibility of equipment and may affect safety and reliability of the complete system. Each person’s connecting subsystem (Energy Absorbing Lanyard or SRL) must limit fall arrest forces to 900 lbs (4 kN).

Figure 5 - Fall Clearance for Energy Absorbing Lanyards

To calculate Fall Clearance:

1. In the shaded column, locate the HLL Span Distance (Y) representing the distance between SecuraSpan Stanchions.
2. In the shaded row, locate the Lanyard Length (X) for the Energy Absorbing Lanyard used with the HLL system.
3. The minimum allowable Vertical Clearance (Z) required from lower level or obstruction to the working surface of the HLL is identified at the intersection of the row (Y) and column (X) determined in Steps 1 and 2.

Y HLL SPAN DISTANCE: ft. (m)	X LANYARD LENGTH: ft-in (m)			
	3 FT (.9)	4 FT (1.2)	5 FT (1.5)	6 FT (1.8)
0-10 (0-3)	11'-2" (3.4)	12'-2" (3.7)	13'-2" (4)	14'-2" (4.3)
10-15 (3-4.6)	11'-10" (3.6)	12'-10" (3.9)	13'-10" (4.2)	14'-10" (4.5)
15-20 (4.6-6.1)	12'-5" (3.8)	13'-5" (4.1)	14'-5" (4.4)	15'-5" (4.7)
20-25 (6.1-7.7)	13' (4)	14' (4.3)	15' (4.6)	16' (4.9)
25-30 (7.7-9.0)	13'-7" (4.2)	14'-7" (4.5)	15'-7" (4.8)	16'-7" (5.1)
30-35 (9.0-10.8)	14'-2" (4.4)	15'-2" (4.6)	16'-2" (4.9)	17'-2" (5.2)
35-40 (10.8-12.3)	14'-10" (4.6)	15'-10" (4.9)	16'-10" (5.2)	17'-10" (5.5)
40-45 (12.3-13.8)	15'-5" (4.7)	16'-5" (5.1)	17'-5" (5.4)	18'-5" (5.6)
45-50 (13.8-15.4)	16' (4.9)	17' (5.2)	18' (5.5)	19' (5.8)
50-55 (15.4-16.9)	16'-7" (5.1)	17'-7" (5.3)	18'-7" (5.6)	19'-7" (6)
55-60 (16.9-18.5)	17'-2" (5.3)	18'-2" (5.6)	19'-2" (5.9)	20'-2" (6.2)

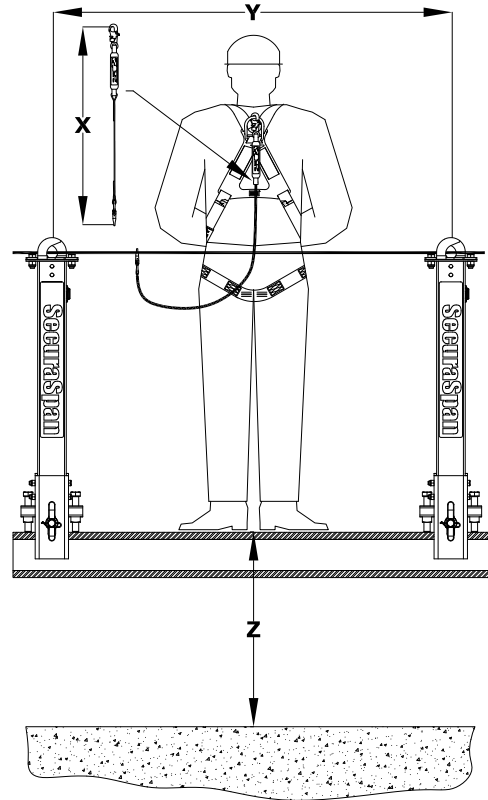
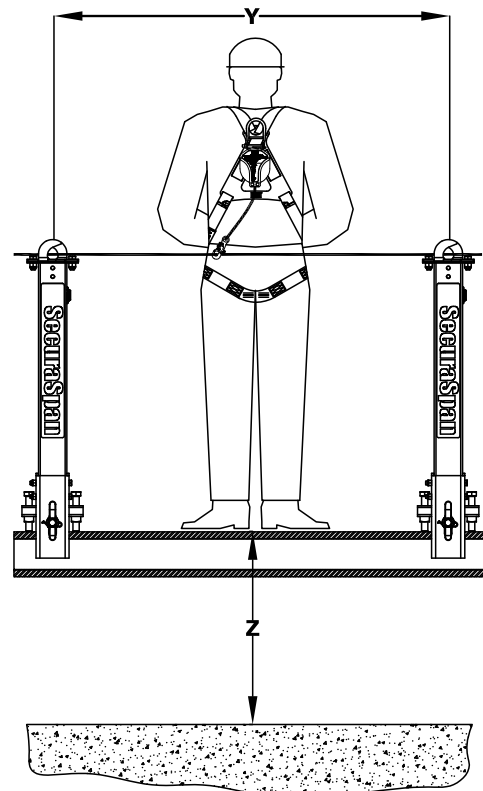

Figure 6 - Fall Clearance for Self Retracting Lifelines

WARNING: Clearances at right only apply to workers located directly adjacent to the HLL with their SRL connected to the HLL immediately next to them. Working away from the point where the SRL connects to the HLL will increase fall clearance.

WARNING: The SecuraSpan HLL system is approved for use with DBI-SALA Talon, DBI-SALA 11-ft. Web UltraLok, and Protecta Rebel SRLs only. Clearance values may not be accurate if used with other SRL models.

Y SPAN ft (m)	Z Clearance ft-in (m)
0-10 (0-3)	10'-9" (3.3)
10-20 (3-6.1)	11'-11" (3.6)
20-30 (6.1-9.0)	13'-2" (4)
30-40 (9.0-12.3)	14'-6" (4.4)
40-50 (12.3-15.4)	15'-7" (4.8)
50-60 (15.4-18.5)	16'-8" (5.1)



2.10 COMPATIBILITY OF CONNECTORS: Connectors are considered to be compatible with connecting elements when they have been designed to work together in such a way that their sizes and shapes do not cause their gate mechanisms to inadvertently open regardless of how they become oriented. Connectors (hooks, carabiners, and D-rings) must be capable of supporting at least 5,000 lbs. (22 kN). Connectors must be compatible with the anchorage or other system components. Do not use equipment that is not compatible. Non-compatible connectors may unintentionally disengage (see Figure 7). Connectors must be compatible in size, shape, and strength. Self-locking snap hooks and carabiners are required by ANSI Z359.1 and OSHA.

2.11 MAKING CONNECTIONS: Use only self-locking snap hooks and carabiners with this equipment. Only use connectors that are suitable to each application. Ensure all connections are compatible in size, shape and strength. Do not use equipment that is not compatible. Ensure all connectors are fully closed and locked.

DBI-SALA connectors (snap hooks and carabiners) are designed to be used only as specified in each product's user's instructions. See Figure 8 for illustration of the inappropriate connections stated below. DBI-SALA snap hooks and carabiners should not be connected:

- A. To a D-ring to which another connector is attached.
- B. In a manner that would result in a load on the gate.
- C. In a false engagement, where features that protrude from the snap hook or carabiner catch on the anchor and without visual confirmation seems to be fully engaged to the anchor point.
- D. To each other.
- E. Directly to webbing or rope lanyard or tie-back (unless the manufacturer's instructions for both the lanyard and connector specifically allow such a connection).
- F. To any object which is shaped or dimensioned such that the snap hook or carabiner will not close and lock, or that roll-out could occur.
- G. In a manner that does not allow the connector to align properly while under load.

NOTE: Other than 3,600 lb. (16 kN) gated hooks, large throat opening snap hooks should not be connected to standard size D-rings or similar objects which will result in a load on the gate if the hook or D-ring twists or rotates. Large throat snap hooks are designed for use on fixed structural elements such as rebar or cross members that are not shaped in a way that can capture the gate of the hook.

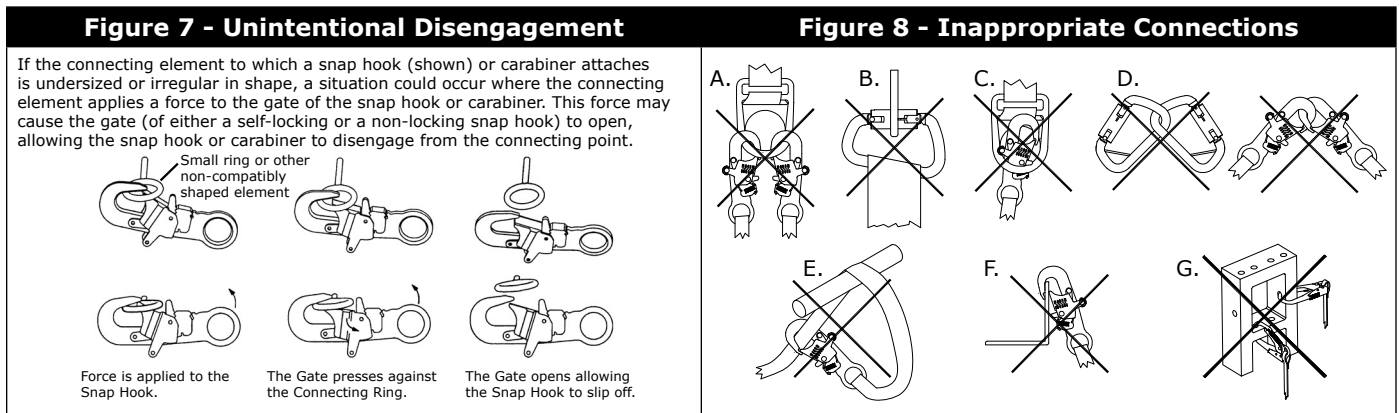

3.0 INSTALLATION

WARNING: Do not alter or intentionally misuse this equipment. Consult Capital Safety when using this equipment in combination with components or subsystems other than those described in this manual. Some subsystem and component combinations may interfere with the operation of this equipment. Use caution when using this equipment around moving machinery, electrical hazards, chemical hazards, and sharp edges.

WARNING: Consult your doctor if there is any reason to doubt your fitness to safely absorb the shock from a fall arrest. Age and fitness seriously affect a workers ability to withstand arrest forces. Pregnant women or minors must not use DBI/SALA SecuraSpan® HLL systems.

3.1 STANCHION INSTALLATION: Figure 1 shows a typical single span and multiple span SecuraSpan® HLL system installations. SecuraSpan HLL systems must be installed to meet the clearance requirements specified in Figure 5 and Figure 6. Details for installing the various components that comprise the SecuraSpan Horizontal Lifeline System are as follows:

- A. STANCHION BEAM CLAMP SIZING:** Figure 2 identifies available Beam Clamp sizes. The standard Stanchion is equipped with a Beam Clamp Assembly that accommodates flange widths from 6 in. - 12 in. (15 cm - 30 cm). Optional Base Clamp Assemblies are available for the flange width ranges identified in Figure 2. All stanchions must be installed on the top flange of the beam. Stanchions must be installed on the beam as described and illustrated in this section (see "Securing the Stanchion on the Beam").
- B. SYSTEM HEIGHT:** The stanchions must be located at a height that will limit the free fall distance to 6 ft. (1.8 m). The length of the Energy Absorbing Lanyard should be limited to reduce the potential free fall. All stanchions must be installed at approximately the same elevation. Limit the lifeline slope to five degrees or less.
- C. SYSTEM DIRECTION:** The SecuraSpan Horizontal Lifeline must be installed straight and horizontal, without turns or bends.
- D. EVALUATION OF STRUCTURE STRENGTH AND HORIZONTAL LIFELINE SPANS:** The location of the stanchions must be determined, and the strengths of the beams must be evaluated according to Beam Load Requirements defined in Section 2.2 and Figure 3.
- E. EVALUATION OF HORIZONTAL LIFELINE SPANS FOR CLEARANCE:** The elevation and length of the system span(s) must be determined to evaluate the horizontal lifeline system clearance. Fall clearance requirements vary depending on which connecting subsystem is used the SecuraSpan HLL. For Energy Absorbing Lanyards, refer to Figure 5 for minimum clearance requirements. For Self Retracting Lifelines, see Figure 6 for minimum clearance requirements. Do not begin installation until clearances have been reviewed and determined to be in compliance with Figure 5 and Figure 6.
- F. SECURING THE STANCHION ON THE BEAM:** Figure 9 illustrates installation of the SecuraSpan I-Beam Stanchion (A) on an I- Beam (B). Stanchions may be attached while the beam is on the ground or when secured overhead. Make sure the Beam Clamp Assembly (C) is open far enough so one end of the I-Beam Flange fits into the slot in the Stanchion Base (D) and the Hook End (E) of the clamp fits over the opposite end of the I-Beam Flange. Secure the Stanchion to the Beam Flange by tightening the Beam Clamp Wing Nut (F) until the the Stanchion Base is drawn completely onto the I-Beam Flange and the Flange is securely engaged between the slot in the Stanchion Base and the Hook End. When the Wing Nut can't be tightened further by hand, strike the Wing Nut with a tool to secure it in place. Tighten the two Mounting Bolts (G) on the top of the Stanchion Base securely with a 1-15/16 inch wrench.

WARNING: Use caution when lifting or transporting stanchions. The Beam Clamp Assembly can become separated from the Stanchion Base.

- G. INSTALLING OPTIONAL CLAMP ASSEMBLIES:** Optional Beam Clamp assemblies are available for use on flange widths up to 36 inches (92 cm). Figure 2 lists available Beam Clamp sizes. Install optional Beam Clamp assemblies as illustrated in Figure 10: Remove the Rue Pin (A) and Wing Nut (B). Grasp the Hook End (C) and slide the Threaded Rod (D) out of the Stanchion Base (E). Insert the Threaded Rod on the new Beam Clamp assembly through the Stanchion Base and secure it to the Stanchion Base with the Wing Nut and Rue Pin.
- H. INSTALLING OPTIONAL PASS -THROUGH BRACKETS:** Any stanchion may be converted to a Pass-Through (Intermediate) Stanchion by installing a Bypass Bracket Kit (7400008). Attach the Pass-Through Brackets (A) to the Stanchion Top (B) with the provided ½-inch Bolts (C) and Locknuts (D) as shown in SecuraSpan. Ensure the Pass-Through Brackets are oriented as shown, with the Hooked Ends curving over the Stanchion Top to contain the HLL Wire Rope assembly.

Figure 9 - Stanchion Installation

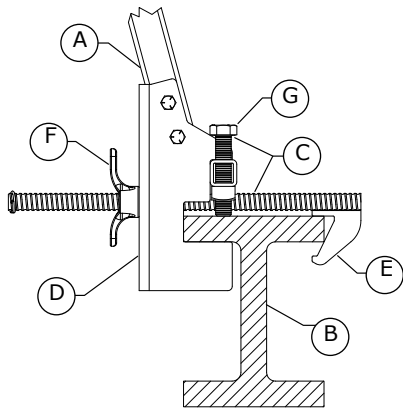

A Stanchion **B** I-Beam **C** Beam Clamp Assembly
D Stanchion Base **E** Hook End **F** Wing Nut **G** Mounting Bolts (2)

Figure 10 - Beam Clamp Installation

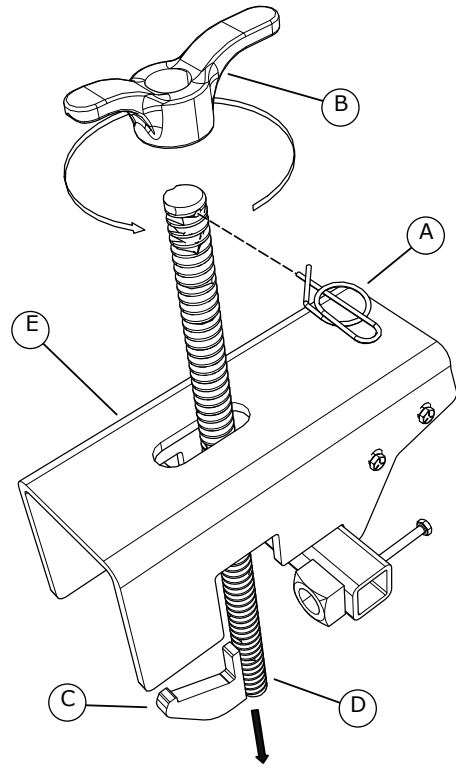

A Rue Pin **B** Wing Nut **C** Hook End **D** Threaded Rod
E Stanchion Base

Figure 11 - Pass-Through Brackets

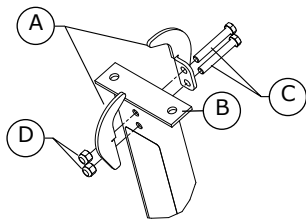

A Pass-Through Brackets **B** Stanchion Top **C** 1/2" Bolts
D Locknuts

3.2 HORIZONTAL LIFELINE INSTALLATION: Figure 12 illustrates installation of SecuraSpan Horizontal Lifeline (HLL) in Single Span and Multiple Span system. Procedures for installing the HLL are as follows:

CAUTION: Multiple span SecuraSpan HLL systems require the use of a Zorbit energy absorber at both end terminations. Failure to do so could result in failure of the system and serious injury or death to the user.

- A.** Connect the Carabiner on the Turnbuckle end of the HLL assembly to the inside hole of the first Stanchion.
- B.** Extend the Turnbuckle so 1/2 in. (13mm) of thread remains exposed in the Turnbuckle body slots.
- C.** When present, route the wire rope through any pass-through brackets.
- D.** Connect the Carabiner on the Thimble Clamp end of the HLL assembly to the inside hole of the last Stanchion. Loosen the Cable Clips at the end of the cable assembly and pull the Wire Rope tight to remove slack. Secure the Cable Clip 1 1/2 in. (28 mm) from the Thimble Clamp as shown in Figure 12. At least 8 in. (20.3 cm) of Wire Rope must extend out from the free Cable Clip. Torque Cable Clips to 45 ft-lbs (61 Nm) and Thimble Clamp Nuts to 40 ft-lbs (54 Nm).
- E.** To pre-load the system, tighten the Wire Rope by rotating the Turnbuckle body. The unrestrained jaw of the Turnbuckle must be prevented from turning to prevent twisting of the Wire Rope. Tension the Wire Rope until the sag on the system at mid-span is 6 in. (15.25 cm) or less with no weight on the Wire Rope. The Turnbuckle will not over-tension the Wire Rope.
- F.** After pre-loading the system, re-torque all Cable Clips to their previously specified values.

NOTE: Two independent SecuraSpan HLL systems may be terminated at the same stanchion.

Figure 12 - Horizontal Lifeline Installation

Single Span HLL Installation

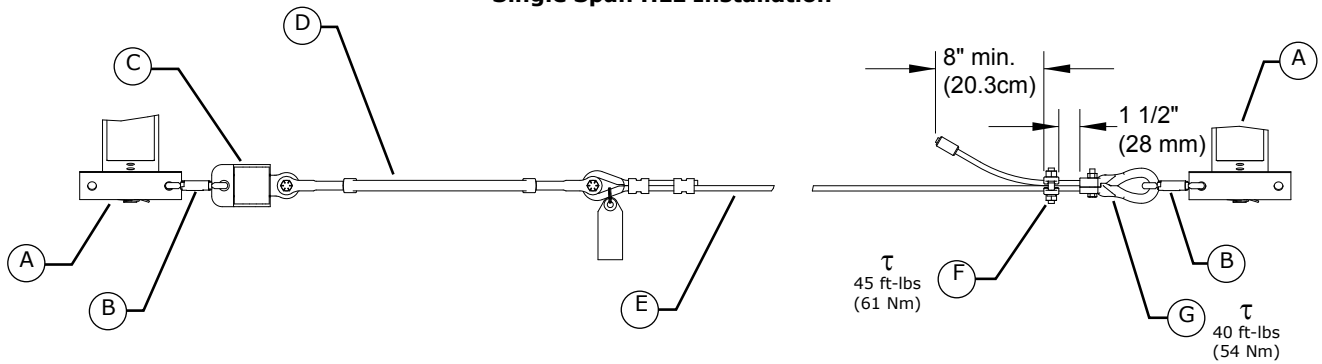

Multiple Span HLL Installation

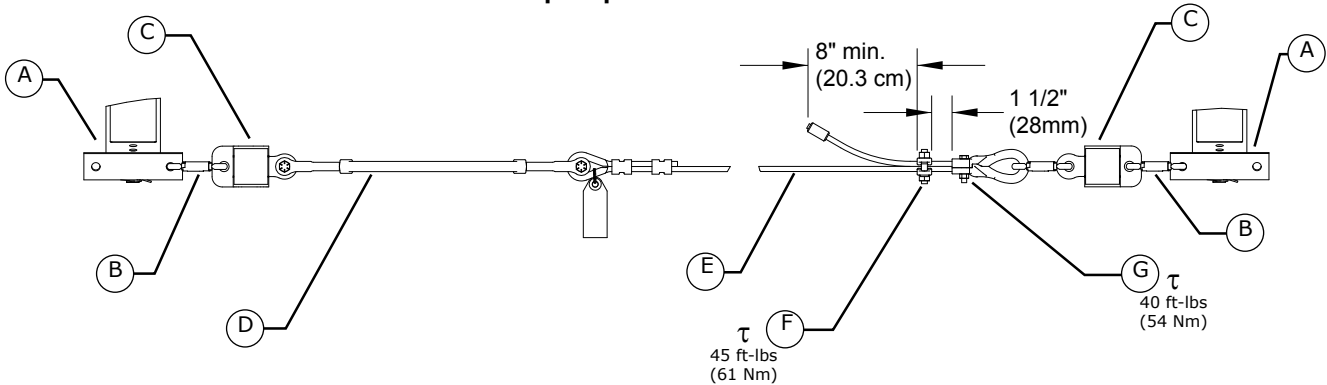

A Stanchion **B** Carabiner **C** Zorbit **D** Turnbuckle **E** Wire Rope Assembly **F** Cable Clip **G** Thimble Clamp

CAUTION: Do not rigidly mount Zorbit to structure or stanchion. May cause failure due to bending. Mount so Zorbit can pivot and move freely as shown in Figure 12.

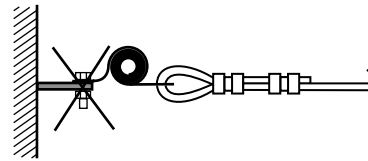

4.0 OPERATION

4.1 BEFORE EACH USE: Inspect the SecuraSpan Horizontal Lifeline System according to inspection procedures in Section 5. Do not use this equipment if inspection reveals an unsafe or defective condition. Plan your use of the fall protection system prior to exposing workers to dangerous situations. Consider all factors affecting your safety before using this system:

- Read and understand all manufacturer's instructions for each component of the personal fall arrest system. All DBI-SALA harnesses and connecting subsystems are supplied with separate user instructions. Keep all instructions for future reference.
- Review Section 1.2 and Section 2 to ensure system limitations and other requirements have been met. Review applicable information regarding system clearance criteria, and ensure changes have not been made to the system installation (i.e. length), or occurred at the job site, that could affect the required fall clearance. Do not use the system if changes are required.

4.2 PERSONAL FALL ARREST SYSTEM COMPONENTS: Inspect and don the Full Body Harness according to manufacturer's instructions. Attach the connecting subsystem (Energy Absorbing Lanyard or SRL) to the Dorsal Connection on the harness (see Figure 13).

WARNING: Risk of swing falls is greater when using an SRL. Swing falls significantly increase the clearance required to arrest a fall and may result in serious injury or death. To avoid swing fall hazards, do not work beyond the end stanchions or at excessive distances to either side of the HLL system. Do not climb above the HLL system.

4.3 CONNECTING TO THE HLL SYSTEM: Approach the work area using the appropriate access equipment. Connect the Personal Fall Arrest System connector (free Snap Hook on the Energy Absorbing Lanyard or Talon SRL, Carabiner on other Web SRLs) to the Horizontal Lifeline's Wire Rope. Connectors must meet all compatibility and strength requirements.

Figure 13 - Personal Fall Arrest Subsystem Connections

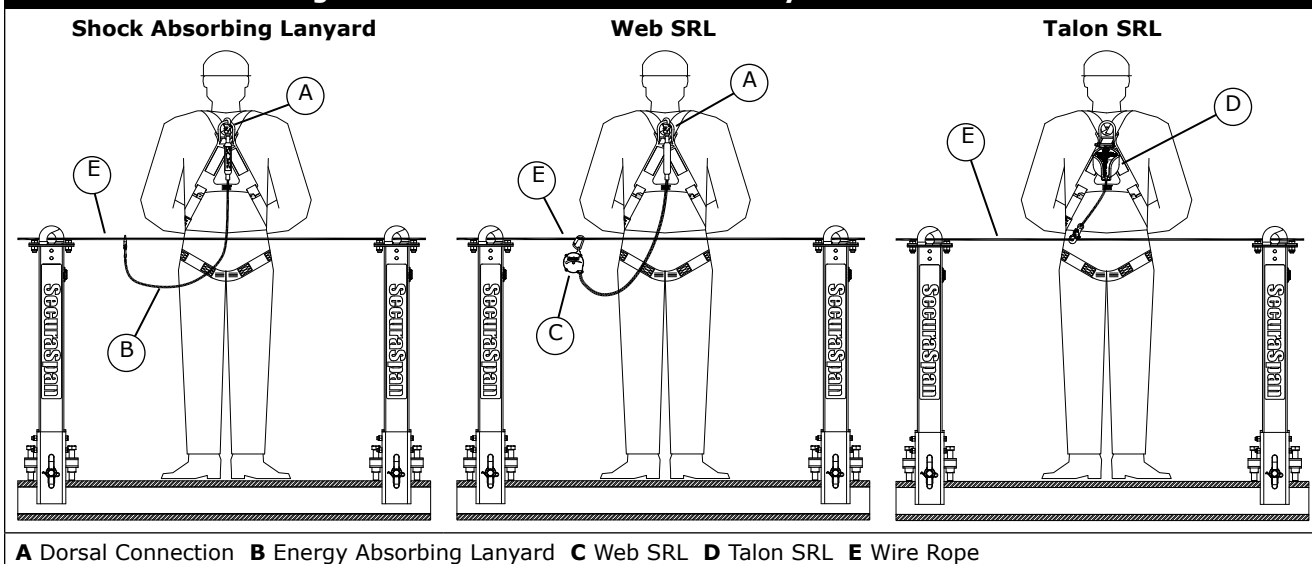

4.4 ONCE CONNECTED TO THE SYSTEM: The user must remain connected to the system. When bypassing a Pass-Through Bracket, the Snap Hook must be rotated upward to navigate around each of the hook shaped guides on the bracket (see Figure 14) Large throat opening Carabiners and Snap Hooks will not allow bypass capabilities. When transferring between two adjacent SecuraSpan HLL Systems, the user must be protected during transfer from one system to the next. A 100 Percent Tie-Off Energy Absorbing Lanyard should be used to protect the user. During transfer from one SecuraSpan system to an adjacent system, attach the unused leg of the lanyard to the next SecuraSpan system before releasing the secured lanyard leg from the first SecuraSpan system.

Figure 14 - Navigating Pass-Through Brackets

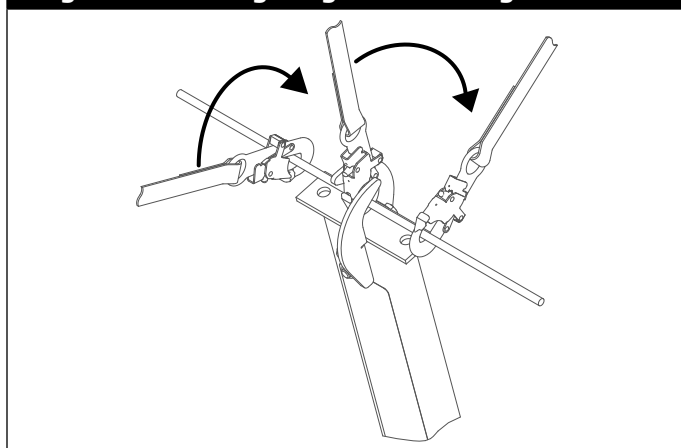

- 4.5 HAZARDOUS SITUATIONS:** Do not take unnecessary risks, such as jumping or reaching too far from the edge of the working surface. Do not allow the connecting subsystem to pass under arms or between feet. To avoid inadequate fall clearance, do not climb above the horizontal lifeline. To avoid swing fall hazards, do not work too far from either side of the system.
- 4.6 TWO PERSONS CONNECTED WITHIN A SINGLE SPAN:** When a person falls while connected to the Horizontal Lifeline, the wire rope will deflect within the span to which the worker is connected. If two persons are connected to the system within the same span, and one person falls, the second person may be pulled off the working surface due to deflection of the HLL. The potential for the second person falling increases as the HLL span length increases.
- 4.7 FREE FALL:** The Personal Fall Arrest System must be rigged to limit free falls to six feet or less when using an energy absorbing lanyard according to OSHA requirements.
- 4.8 SHARP EDGES:** Avoid working where the connecting subsystem or other system components will be in contact with, or abrade against, unprotected sharp edges. If working around sharp edges is unavoidable, a protective cover must be used to prevent cutting of the Personal Fall Arrest System (PFAS) components.
- 4.9 IN THE EVENT OF A FALL:** The responsible party must have a rescue plan and the ability to implement a rescue. Tolerable suspension time in a full body harness is limited, so a prompt rescue is critical.

IMPORTANT: Use care when handling an expended Zorbit Energy Absorber. The tearing of the energy absorber material produces extremely sharp edges.

4.10 RESCUE: With the number of potential scenarios for a worker requiring rescue, an on-site rescue team is beneficial. The rescue team is given the tools, both in equipment and techniques, so it can perform a successful rescue. Training should be provided on a periodic basis to ensure rescuers' proficiency.

4.11 SYSTEM REMOVAL: When no longer required, the system should be removed from the job site. To slacken the wire rope, loosen the turnbuckle until tension is removed from the wire rope. Remove the carabiners that connect the wire rope to the end stanchions. Ensure there are no knots or kinks in the wire rope before storage.

5.0 INSPECTION

5.1 FREQUENCY: Table 1 defines the procedures for inspecting the SecuraSpan Horizontal Lifeline System. Frequency and inspector qualifications are as follows:

- **Before Each Use:** An inspection of the system by a qualified person must be completed after the system is installed and prior to each day's use. Inspect per the procedures defined in Table 1.
- **Annual Inspection:** System components must be formally inspected by a qualified person, other than the user, at least annually. Extreme working conditions may require increasing inspection frequency. Inspect per the procedures defined in Table 1. Record inspection results in the *Inspection and Maintenance Log* in Section 9.

5.4 I-Safe™ RFID TAG: The SecuraSpan I-Beam Stanchion includes an i-Safe™ Radio Frequency Identification (RFID) tag (Figure 18). The RFID tag can be used in conjunction with the i-Safe handheld reading device and web based portal to simplify inspection and inventory control and provide records for your fall protection equipment. If you are a first-time user, contact a Capital Safety Customer Service representative (see back cover); or if you have already registered, go to www.capitalsafety.com/isafe.html. Follow the instructions provided with your i-Safe handheld reader or on the web portal to transfer your data to your web log.

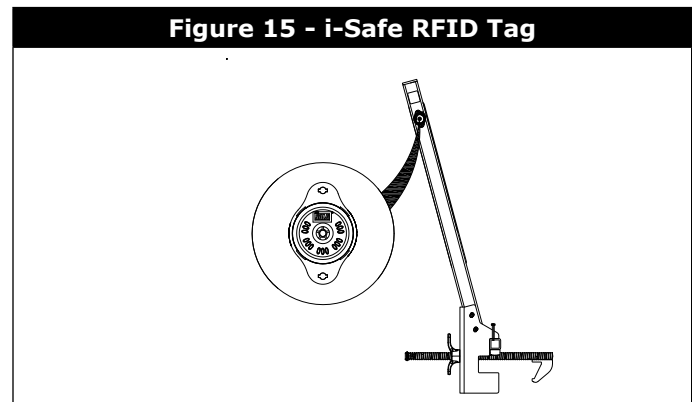

5.2 IF INSPECTION REVEALS AN UNSAFE OR DEFECTIVE CONDITION: Remove the unit from service and destroy, or contact Capital Safety for possible repair.

IMPORTANT: If the Horizontal Lifeline System is subjected to the forces of a fall arrest, it must be removed from service and destroyed, or returned to Capital Safety for inspection or repair.

Table 1 - Inspection

Inspection Procedures:	Daily	Before Each Use	Every Year	After a Fall
1. Inspect the Turnbuckle for damage. Ensure sufficient threads are engaged into the Turnbuckle body. Look for any cracks or deformities in the metal. Inspect metal components for rust or corrosion that may affect their strength or operation.		X	X	X
2. Inspect the Wire Rope for rust, corrosion, broken wires, or other obvious faults. Inspect the Wire Rope for proper tension. Inspect all hardware (fasteners, carabiners, wire rope cable clips, etc.) securing the HLL assembly to ensure they are present and properly installed.		X	X	X
3. Inspect the Zorbit Energy Absorber for extension or deformities. There should be no tearing of the metal between holes in the Zorbit coiled section. Increase inspection frequency if the Zorbit is exposed to prolonged vibration. Extended Zorbit Energy Absorbers must be removed from service and destroyed, or marked for training only. Inspect securing hardware for strength and function.		X	X	X
4. Inspect system labels. The labels must be present and fully legible (see Section 8). Replace labels if missing or illegible.		X	X	X
5. The Stanchion mounting bolts and wing nuts must be retightened daily.	X			

IMPORTANT: If inspection reveals an unsafe or defective condition: Remove the unit from service and destroy, or contact Capital Safety for possible repair.

5.3 USER EQUIPMENT: Inspect Harnesses, Energy Absorbing Lanyards, and SRLs used with the HLL system according to manufacturer's instructions.

6.0 MAINTENANCE, SERVICE, AND STORAGE

- 6.1 SECURASPAN HLL COMPONENTS:** The SecuraSpan® HLL components require no scheduled maintenance, other than repair or replacement of items found defective during inspection (see Section 5). If components become heavily soiled with grease, paint, or other substances, clean with appropriate cleaning solutions. Do not use caustic chemicals that could damage system components. Store HLL components in a clean, dry, cool, enclosure.
- 6.2 CONNECTING SUBSYSTEM COMPONENTS:** Maintain, service, and store user subsystem equipment (Harnesses, Lanyards, Srls, etc.) according to manufacturer's instructions.

7.0 SPECIFICATIONS

- 7.1 STANDARDS:** When installed per the requirements and recommendations in this instruction manual, the SecuraSpan Horizontal Lifeline System complies with OSHA 1910.66 and OSHA 1926.502..

7.2 MATERIALS:

Stanchion and Base:	Carbon Steel, Zinc Plated Finish
Zorbit Energy Absorber:	Stainless Steel
Wire Rope:	3/8 in. (10 mm) diameter, 7x19 galvanized wire rope. Minimum tensile strength 14,400 lbs (64 kN)
Cable Assembly Components:	Turnbuckle, Thimble, and Cable Clips are Galvanized Steel
Mounting Hardware and Carabiners:	Zinc Plated Steel

7.3 PERFORMANCE:

Stanchion and Base:

Beam Sizes:	Fits I-Beam Flanges 6 in. - 12 in (15.24 cm) wide and 2-1/4 in (5.72 cm) thick
Capacity:	310 lbs (141 kg)
Weight:	36 lbs (16.33 kg)
Height of Installed Stanchion:	36" (91.44 cm)
Minimum Breaking Strength:	5,000 lbs (22.2 kN)

Zorbit Energy Absorber:

Peak Dynamic Pullout Load:	2,500 lbs (11 kN)
Average Dynamic Pullout Load:	2,000 lbs (8.9 kN)
Maximum Pullout:	48.5 in (1.25 m)
Minimum Tensile Strength:	5,000 lbs (22.2 kN)
US Patent Number:	6,279,680

8.0 LABELING

The following labels must be present and fully legible:

8.1 SECURASPIN I-BEAM STANCHION:

DBI SALA i-Safe

This product is i-Safe enabled and contains an electronic tag that can be read by compatible readers – providing inspection logs, inventory management and other safety information.
Ce produit est validé dans i-Safe et contient une rondelle d'identification électronique qui peut être lue par des lecteurs compatibles – en fournissant des registres d'inspection, de l'informations sur la gestion des stocks et d'autre information relative à la protection.
9502313 Rev. C

WARNING

This product is an electrical safety device. The user must read and understand any use instructions supplied with this product. Must be followed by user and supervisor and must be followed at all times. Failure to follow instructions may result in injury or death. Read all applicable warnings. This product is designed to be used only on the surface of a qualified person. Exercise caution when using this equipment near energized electrical equipment or overhead power lines. The product must not be used near energized electrical equipment. The distance between the user and the energized equipment must be at least 10 feet (3 m) for non-qualified users and at least 4 feet (1.2 m) for qualified users. Do not touch the energized equipment with the product. Use of the product in other than the intended manner may result in injury or death. See the user manual for more information. © 2010 DBI SALA. All rights reserved. This document is the property of DBI SALA. No part of this document may be reproduced without the prior written permission of DBI SALA.

WARNING

ATTENTION: LIRE ATTENTIVEMENT LES INSTRUCTIONS D'UTILISATION. SI CE DISPOSITIF N'EST PAS UTILISÉ EN CONFORMITÉ AVEC LES INSTRUCTIONS D'UTILISATION, IL PEUT Y AVOIR DES RISQUES DE BLESSURE OU DE LA MORT. LIRE TOUJOURS LES Avertissements de sécurité. Ce produit est conçu pour être utilisé uniquement sur la surface d'un utilisateur qualifié. Exercer la prudence lors de l'utilisation de cet équipement près d'équipement électrique chargé ou de lignes à haute tension. Ce produit ne doit pas être utilisé à proximité d'équipement électrique chargé. La distance entre l'utilisateur et l'équipement électrique chargé doit être d'au moins 10 pieds (3 m) pour les utilisateurs non qualifiés et d'au moins 4 pieds (1,2 m) pour les utilisateurs qualifiés. Ne touchez pas l'équipement électrique avec le produit. Ne pas utiliser le produit de toute autre manière que prévue. Voir le manuel de l'utilisateur pour plus d'informations. © 2010 DBI SALA. Tous droits réservés. Ce document est la propriété de DBI SALA. Aucune partie de ce document ne peut être reproduite sans la permission écrite préalable de DBI SALA.

CLEARANCE CHART

NET HEIGHT	13'6"	14'0"	14'6"	15'0"	15'6"
MINIMUM CLEARANCE	5'3"	5'7"	6'1"	6'5"	6'9"
MAXIMUM CLEARANCE	11'0"	11'4"	11'8"	12'2"	12'6"
TOTAL HEIGHT	16'3"	16'7"	17'1"	17'5"	17'9"

CAPACITY: 2 USERS PER SPAN
MAXIMUM: 20250 lbs (9.2 t)

8.2 HORIZONTAL LIFELINE (HLL):

SYSTEM WORKING LENGTH:
LONGUEUR DE FONCTIONNEMENT DU DISPOSITIF:

_____ FT. _____ m

MFRD_(YRMO) LOT: / Lot de FABR_(FAMM) MODEL NO: / N° de modèle

DBI SALA

USA: (800) 328-6146
CAN/ADA: (800) 387-7484
WWW.CAPITALSAFETY.COM
9500065 REV E

9502409 Rev. C

This product is i-Safe enabled, and contains an electronic tag that can be read by compatible readers – providing inspection logs, inventory management and other safety information.
Ce produit est validé dans i-Safe et contient une rondelle d'identification électronique qui peut être lue par des lecteurs compatibles – en assurant des registres d'inspection, de l'informations sur la gestion des stocks et d'autre information relative à la protection.
www.capitalsafety.com

8.3 ZORBIT ENERGY ABSORBY:

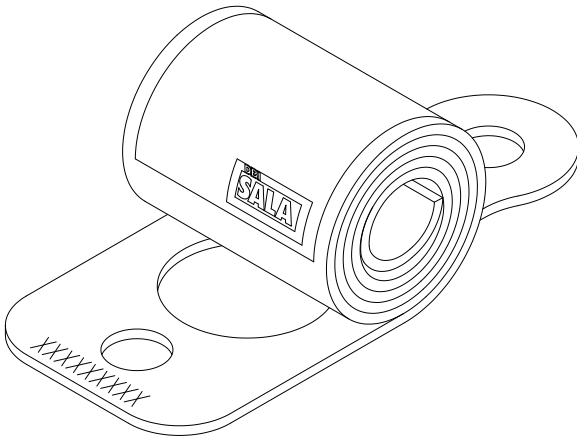

⚠ WARNING

THIS HORIZONTAL LIFELINE ENERGY ABSORBER (EAHLL) MUST ONLY BE USED AS PART OF A DBI-SALA HORIZONTAL LIFELINE SUBSYSTEM (HLLSS), OR, AS PART OF A COMPLETE PERSONAL FALL ARREST SYSTEM INCORPORATING A HLLSS WHICH MAINTAINS A SAFETY FACTOR OF AT LEAST TWO, DESIGNED, INSTALLED AND USED UNDER THE SUPERVISION OF A QUALIFIED PERSON. REFERENCE OSHA REGULATIONS. DO NOT USE AS A PERSONAL ENERGY ABSORBER. MANUFACTURER'S INSTRUCTIONS SUPPLIED WITH THIS PRODUCT AT TIME OF SHIPMENT MUST BE FOLLOWED. FAILURE TO DO SO COULD RESULT IN SERIOUS INJURY OR DEATH.

ZORBIT™
ENERGY ABSORBER FOR HORIZONTAL LIFELINE SYSTEMS

SPECIFICATIONS: MATERIAL - STAINLESS STEEL; PEAK DYNAMIC PULLOUT LOAD - 2500 LBS.; AVERAGE DYNAMIC PULLOUT LOAD - 2000 LBS.; MAXIMUM PULLOUT - 48.5 INCHES; ULTIMATE STRENGTH - 5000 LBS.; MODEL - 7401013
PATENT PENDING MADE IN USA

www.capitalsafety.com

USA: (800) 328-6146

CANADA: (800) 387-7484



Models	Description
7400420	20 ft. Complete SecuraSpan I-Beam System
7400430	30 ft. Complete SecuraSpan I-Beam System
7400440	40 ft. Complete SecuraSpan I-Beam System
7400450	50 ft. Complete SecuraSpan I-Beam System
7400460	60 ft. Complete SecuraSpan I-Beam System
7400008	SecuraSpan Intermediate Bypass Bracket Kit
7400047	SecuraSpan Stanchion and I-Beam Base with 6" - 12" Beam Clamp
7400055	SecuraSpan Stanchion and I-Beam Base with 6" - 18" Beam Clamp
7400056	SecuraSpan Stanchion and I-Beam Base with 6" - 24" Beam Clamp
7400057	SecuraSpan Stanchion and I-Beam Base with 6" - 36" Beam Clamp
7400052	SecuraSpan I-Beam Base Retrofit Kit with 6" - 12" Beam Clamp
7400065	SecuraSpan I-Beam Base Retrofit Kit with 6" - 18" Beam Clamp
7400066	SecuraSpan I-Beam Base Retrofit Kit with 6" - 24" Beam Clamp
7400067	SecuraSpan I-Beam Base Retrofit Kit with 6" - 36" Beam Clamp
7400070	18" High SecuraSpan Stanchion and I-Beam Base with 6" - 12" Beam Clamp
7400071	18" High SecuraSpan Stanchion and I-Beam Base with 6" - 18" Beam Clamp

LIMITED LIFETIME WARRANTY

Warranty to End User: D B Industries, Inc., dba CAPITAL SAFETY USA ("CAPITAL SAFETY") warrants to the original end user ("End User") that its products are free from defects in materials and workmanship under normal use and service. This warranty extends for the lifetime of the product from the date the product is purchased by the End User, in new and unused condition, from a CAPITAL SAFETY authorized distributor. CAPITAL SAFETY'S entire liability to End User and End User's exclusive remedy under this warranty is limited to the repair or replacement in kind of any defective product within its lifetime (as CAPITAL SAFETY in its sole discretion determines and deems appropriate). No oral or written information or advice given by CAPITAL SAFETY, its distributors, directors, officers, agents or employees shall create any different or additional warranties or in any way increase the scope of this warranty. CAPITAL SAFETY will not accept liability for defects that are the result of product abuse, misuse, alteration or modification, or for defects that are due to a failure to install, maintain, or use the product in accordance with the manufacturer's instructions.

CAPITAL SAFETY'S WARRANTY APPLIES ONLY TO THE END USER. THIS WARRANTY IS THE ONLY WARRANTY APPLICABLE TO OUR PRODUCTS AND IS IN LIEU OF ALL OTHER WARRANTIES AND LIABILITIES, EXPRESSED OR IMPLIED. CAPITAL SAFETY EXPRESSLY EXCLUDES AND DISCLAIMS ANY IMPLIED WARRANTIES OF MERCHANTABILITY OR FITNESS FOR A PARTICULAR PURPOSE, AND SHALL NOT BE LIABLE FOR INCIDENTAL, PUNITIVE OR CONSEQUENTIAL DAMAGES OF ANY NATURE, INCLUDING WITHOUT LIMITATION, LOST PROFITS, REVENUES, OR PRODUCTIVITY, OR FOR BODILY INJURY OR DEATH OR LOSS OR DAMAGE TO PROPERTY, UNDER ANY THEORY OF LIABILITY, INCLUDING WITHOUT LIMITATION, CONTRACT, WARRANTY, STRICT LIABILITY, TORT (INCLUDING NEGLIGENCE) OR OTHER LEGAL OR EQUITABLE THEORY.



The Ultimate in Fall Protection

CSG USA & Latin America

3833 SALA Way
Red Wing, MN 55066-5005
Toll Free: 800.328.6146
Phone: 651.388.8282
Fax: 651.388.5065
solutions@capitalsafety.com

CSG Canada

260 Export Boulevard
Mississauga, ON L5S 1Y9
Phone: 905.795.9333
Toll-Free: 800.387.7484
Fax: 888.387.7484
info.ca@capitalsafety.com

CSG Northern Europe

5a Merse Road
North Moons, Moat
Reditch, Worcestershire, UK
B98 9HL
Phone: + 44 (0)1527 548 000
Fax: + 44 (0)1527 591 000
csgne@capitalsafety.com

CSG EMEA (Europe, Middle East, Africa)

Le Broc Center
Z.I. 1ère Avenue
5600 M B.P. 15 06511
Carros
Le Broc Cedex
France
Phone: + 33 4 97 10 00 10
Fax: + 33 4 93 08 79 70
information@capitalsafety.com

CSG Australia & New Zealand

95 Derby Street
Silverwater
Sydney NSW 2128
AUSTRALIA
Phone: +(61) 2 8753 7600
Toll-Free : 1 800 245 002 (AUS)
Toll-Free : 0800 212 505 (NZ)
Fax: +(61) 2 87853 7603
sales@capitalsafety.com.au

CSG Asia

Singapore:
16S, Enterprise Road
Singapore 627666
Phone: +65 - 65587758
Fax: +65 - 65587058
inquiry@capitalsafety.com

Shanghai:

Rm 1406, China Venturetech Plaza
819 Nan Jing Xi Rd,
Shanghai 200041, P R China
Phone: +86 21 62539050
Fax: +86 21 62539060

www.capitalsafety.com

